



# Table of contents

Column X: An automatically generated page was edited

F06\_001

Page	Page description	supplementary page field	Date	Edited by	X
&MAA/1	Title page / cover sheet		1/3/2023	MKLEPADLO	
&MAB/1	Table of contents : &MAA/1 - &MFS=V1AR201UQ41KF1+V1AR201UQ41/5		1/4/2023	MKLEPADLO	
&MAB/2	Table of contents : &MFS=V1AR201UQ41KF1+V1AR201UQ41/11 - &MFS=V1WR1UQ51UQ11+V1WR1UQ51/1		1/4/2023	MKLEPADLO	
&MAB/3	Table of contents : &MFS=V1WR1UQ51UQ12+V1WR1UQ51/1 - &MPB+KH0/1		1/4/2023	MKLEPADLO	
&MAB/4	Table of contents : &MPB+KH1/1 - &MPB+V2WR1UQ52/1		1/4/2023	MKLEPADLO	
&MFS=KH0+KH0/1	Incoming air supply		1/4/2023	MKLEPADLO	
&MFS=V1AR11UQ41KF1+V1AR11UQ41/1	AIR SUPPLY GRIPPER		1/4/2023	MKLEPADLO	
&MFS=V1AR11UQ41KF1+V1AR11UQ41/5	AIR SUPPLY		1/4/2023	MKLEPADLO	
&MFS=V1AR11UQ41KF1+V1AR11UQ41/11	AIR SUPPLY		1/4/2023	MKLEPADLO	
&MFS=V1AR11UQ41UQ1+V1AR11UQ41/1	Clamps 1		1/4/2023	MKLEPADLO	
&MFS=V1AR11UQ41UQ2+V1AR11UQ41/1	Clamp 2		1/4/2023	MKLEPADLO	
&MFS=V1AR11UQ41UQ3+V1AR11UQ41/1	Clamp 3		1/4/2023	MKLEPADLO	
&MFS=V1AR11UQ41UQ4+V1AR11UQ41/1	Clamps 4		1/4/2023	MKLEPADLO	
&MFS=V1AR11UQ42KF1+V1AR11UQ42/1	AIR SUPPLY GRIPPER		1/4/2023	MKLEPADLO	
&MFS=V1AR11UQ42KF1+V1AR11UQ42/5	AIR SUPPLY		1/4/2023	MKLEPADLO	
&MFS=V1AR11UQ42KF1+V1AR11UQ42/11	AIR SUPPLY		1/4/2023	MKLEPADLO	
&MFS=V1AR11UQ42UQ1+V1AR11UQ42/1	Clamps 1		1/4/2023	MKLEPADLO	
&MFS=V1AR11UQ42UQ2+V1AR11UQ42/1	Clamps 2		1/4/2023	MKLEPADLO	
&MFS=V1AR11UQ42UQ3+V1AR11UQ42/1	Clamps 3		1/4/2023	MKLEPADLO	
&MFS=V1AR11UQ42UQ4+V1AR11UQ42/1	Vacuums 4		1/4/2023	MKLEPADLO	
&MFS=V1AR11UQ42UQ5+V1AR11UQ42/1	Vacuums 5		1/4/2023	MKLEPADLO	
&MFS=V1AR11UQ42UQ6+V1AR11UQ42/1	Vacuums 6		1/4/2023	MKLEPADLO	
&MFS=V1AR11UQ43KF1+V1AR11UQ43/1	AIR SUPPLY GRIPPER		1/4/2023	MKLEPADLO	
&MFS=V1AR11UQ43KF1+V1AR11UQ43/5	AIR SUPPLY		1/4/2023	MKLEPADLO	
&MFS=V1AR11UQ43KF1+V1AR11UQ43/11	AIR SUPPLY		1/4/2023	MKLEPADLO	
&MFS=V1AR11UQ43UQ1+V1AR11UQ43/1	Vacuums 1		1/4/2023	MKLEPADLO	
&MFS=V1AR11UQ43UQ2+V1AR11UQ43/1	Vacuums 2		1/4/2023	MKLEPADLO	
&MFS=V1AR11UQ43UQ3+V1AR11UQ43/1	Clamps 3		1/4/2023	MKLEPADLO	
&MFS=V1AR11UQ43UQ4+V1AR11UQ43/1	Clamps 4		1/4/2023	MKLEPADLO	
&MFS=V1AR11UQ43UQ5+V1AR11UQ43/1	Clamps 5		1/4/2023	MKLEPADLO	
&MFS=V1AR11UQ43UQ6+V1AR11UQ43/1	Spare		1/4/2023	MKLEPADLO	
&MFS=V1AR201UQ41KF1+V1AR201UQ41/1	AIR SUPPLY GRIPPER		1/4/2023	MKLEPADLO	
&MFS=V1AR201UQ41KF1+V1AR201UQ41/5	AIR SUPPLY		1/4/2023	MKLEPADLO	

&MAA/1

2

Date	1/4/2023	Volvo Trucks North America	Valiant TMS	Table of contents : &MAA/1 - &MFS=V1AR201UQ41KF1+V1AR201UQ41/5	Drawing name: =2V08&MFS-PNEU	=	
Ed.	MKLEPADLO	P6700 Side Skin Roof Outer - Cell 2V08		Scale 1:1	Document type: MAB	Project nr: 22-16147	Page 1
Appr					Replacement of	Replaced by	
Modification	Date	Name	Original				

# Table of contents

Column X: An automatically generated page was edited

F06\_001

Page	Page description	supplementary page field	Date	Edited by	X
&MFS=V1AR201UQ41KF1+V1AR201UQ41/1	AIR SUPPLY		1/4/2023	MKLEPADLO	
&MFS=V1AR201UQ41UQ1+V1AR201UQ41/1	Clamps		1/4/2023	MKLEPADLO	
&MFS=V1AR201UQ41UQ2+V1AR201UQ41/1	Spare		1/4/2023	MKLEPADLO	
&MFS=V1AR201UQ42KF1+V1AR201UQ42/1	AIR SUPPLY GRIPPER		1/4/2023	MKLEPADLO	
&MFS=V1AR201UQ42KF1+V1AR201UQ42/1	AIR SUPPLY		1/4/2023	MKLEPADLO	
&MFS=V1AR201UQ42KF1+V1AR201UQ42/1	AIR SUPPLY		1/4/2023	MKLEPADLO	
&MFS=V1AR201UQ42UQ1+V1AR201UQ42/1	Clamps 1		1/4/2023	MKLEPADLO	
&MFS=V1AR201UQ42UQ2+V1AR201UQ42/1	Clamps 2		1/4/2023	MKLEPADLO	
&MFS=V1AR201UQ42UQ3+V1AR201UQ42/1	Clamps 3		1/4/2023	MKLEPADLO	
&MFS=V1AR201UQ42UQ4+V1AR201UQ42/1	Clamps 4		1/4/2023	MKLEPADLO	
&MFS=V1GM1+KH1/1	Incoming air supply (Lift Assist)		1/4/2023	MKLEPADLO	
&MFS=V1GM2+KH1/1	Incoming air supply (Lift Assist)		1/4/2023	MKLEPADLO	
&MFS=V1PF1+KH1/1	Incoming air supply (Fixture)		1/4/2023	MKLEPADLO	
&MFS=V1PF1KF1+V1PF1/5	AIR SUPPLY CONFIGURATION		1/4/2023	MKLEPADLO	
&MFS=V1PF1KF1+V1PF1/11	AIR SUPPLY		1/4/2023	MKLEPADLO	
&MFS=V1PF1UQ1+V1PF1/1	Clamp		1/4/2023	MKLEPADLO	
&MFS=V1PF1UQ2+V1PF1/1	Spare		1/4/2023	MKLEPADLO	
&MFS=V1WR1+KH1/1	Incoming air supply (Turn Table)		1/4/2023	MKLEPADLO	
&MFS=V1WR1UQ51KF1+V1WR1UQ51/5	AIR SUPPLY CONFIGURATION		1/4/2023	MKLEPADLO	
&MFS=V1WR1UQ51KF1+V1WR1UQ51/1	AIR SUPPLY		1/4/2023	MKLEPADLO	
&MFS=V1WR1UQ51KF2+V1WR1UQ51/5	AIR SUPPLY CONFIGURATION		1/4/2023	MKLEPADLO	
&MFS=V1WR1UQ51KF2+V1WR1UQ51/1	AIR SUPPLY		1/4/2023	MKLEPADLO	
&MFS=V1WR1UQ51UQ1+V1WR1UQ51/1	Shot Pins 1		1/4/2023	MKLEPADLO	
&MFS=V1WR1UQ51UQ2+V1WR1UQ51/1	Cyl Slide 2		1/4/2023	MKLEPADLO	
&MFS=V1WR1UQ51UQ3+V1WR1UQ51/1	Dump Clamp 3		1/4/2023	MKLEPADLO	
&MFS=V1WR1UQ51UQ4+V1WR1UQ51/1	Dump Clamp 4		1/4/2023	MKLEPADLO	
&MFS=V1WR1UQ51UQ5+V1WR1UQ51/1	Clamps 5		1/4/2023	MKLEPADLO	
&MFS=V1WR1UQ51UQ6+V1WR1UQ51/1	Clamps 6		1/4/2023	MKLEPADLO	
&MFS=V1WR1UQ51UQ7+V1WR1UQ51/1	Clamps 7		1/4/2023	MKLEPADLO	
&MFS=V1WR1UQ51UQ8+V1WR1UQ51/1	Clamp 8		1/4/2023	MKLEPADLO	
&MFS=V1WR1UQ51UQ9+V1WR1UQ51/1	Clamp 9		1/4/2023	MKLEPADLO	
&MFS=V1WR1UQ51UQ10+V1WR1UQ51/1	Clamp 10		1/4/2023	MKLEPADLO	
&MFS=V1WR1UQ51UQ11+V1WR1UQ51/1	Clamps 11		1/4/2023	MKLEPADLO	

# Table of contents

Column X: An automatically generated page was edited

F06\_001

Page	Page description	supplementary page field	Date	Edited by	X
&MFS=V1WR1UQ51UQ12+V1WR1UQ51/1	Clamps 12		1/4/2023	MKLEPADLO	
&MFS=V1WR1UQ52KF1+V1WR1UQ52/5	AIR SUPPLY CONFIGURATION		1/4/2023	MKLEPADLO	
&MFS=V1WR1UQ52KF1+V1WR1UQ52/1	AIR SUPPLY		1/4/2023	MKLEPADLO	
&MFS=V1WR1UQ52UQ1+V1WR1UQ52/1	Shot Pins 1		1/4/2023	MKLEPADLO	
&MFS=V1WR1UQ52UQ2+V1WR1UQ52/1	Cyl Slide 2		1/4/2023	MKLEPADLO	
&MFS=V1WR1UQ52UQ3+V1WR1UQ52/1	Dump Clamp 3		1/4/2023	MKLEPADLO	
&MFS=V1WR1UQ52UQ4+V1WR1UQ52/1	Dump Clamp 4		1/4/2023	MKLEPADLO	
&MFS=V1WR1UQ52UQ5+V1WR1UQ52/1	Clamps 5		1/4/2023	MKLEPADLO	
&MFS=V1WR1UQ52UQ6+V1WR1UQ52/1	Clamps 6		1/4/2023	MKLEPADLO	
&MFS=V1WR1UQ52UQ7+V1WR1UQ52/1	Clamps 7		1/4/2023	MKLEPADLO	
&MFS=V1WR1UQ52UQ8+V1WR1UQ52/1	Clamp 8		1/4/2023	MKLEPADLO	
&MFS=V1WR1UQ52UQ9+V1WR1UQ52/1	Clamp 9		1/4/2023	MKLEPADLO	
&MFS=V1WR1UQ52UQ10+V1WR1UQ52/1	Spare		1/4/2023	MKLEPADLO	
&MFS=V2AR181XQ93+KH1/1	Incoming air supply (Fume Extractor)		1/4/2023	MKLEPADLO	
&MFS=V2LB1+KH1/1	Incoming air supply (Fixture)		1/4/2023	MKLEPADLO	
&MFS=V2LB1KF1+V2LB1/5	AIR SUPPLY CONFIGURATION		1/4/2023	MKLEPADLO	
&MFS=V2LB1KF1+V2LB1/11	AIR SUPPLY		1/4/2023	MKLEPADLO	
&MFS=V2LB1UQ1+V2LB1/1	Cylinders 1		1/4/2023	MKLEPADLO	
&MFS=V2LB1UQ2+V2LB1/1	Cylinders 2		1/4/2023	MKLEPADLO	
&MFS=V2WR1+KH1/1	Incoming air supply (Turn Table)		1/4/2023	MKLEPADLO	
&MFS=V2WR1UQ51KF1+V2WR1UQ51/5	AIR SUPPLY CONFIGURATION		1/4/2023	MKLEPADLO	
&MFS=V2WR1UQ51KF1+V2WR1UQ51/1	AIR SUPPLY		1/4/2023	MKLEPADLO	
&MFS=V2WR1UQ51UQ1+V2WR1UQ51/1	Shot Pins 1		1/4/2023	MKLEPADLO	
&MFS=V2WR1UQ51UQ2+V2WR1UQ51/1	Clamps 2		1/4/2023	MKLEPADLO	
&MFS=V2WR1UQ51UQ3+V2WR1UQ51/1	Clamps 3		1/4/2023	MKLEPADLO	
&MFS=V2WR1UQ51UQ4+V2WR1UQ51/1	Shot Pins 4		1/4/2023	MKLEPADLO	
&MFS=V2WR1UQ52KF1+V2WR1UQ52/5	AIR SUPPLY CONFIGURATION		1/4/2023	MKLEPADLO	
&MFS=V2WR1UQ52KF1+V2WR1UQ52/1	AIR SUPPLY		1/4/2023	MKLEPADLO	
&MFS=V2WR1UQ52UQ1+V2WR1UQ52/1	Shot Pins 1		1/4/2023	MKLEPADLO	
&MFS=V2WR1UQ52UQ2+V2WR1UQ52/1	Clamps 2		1/4/2023	MKLEPADLO	
&MFS=V2WR1UQ52UQ3+V2WR1UQ52/1	Clamps 3		1/4/2023	MKLEPADLO	
&MFS=V2WR1UQ52UQ4+V2WR1UQ52/1	Spare		1/4/2023	MKLEPADLO	
&MPB+KH0/1	Parts list : FES.535031 - FES.8030308		1/4/2023	MKLEPADLO	

Date	1/4/2023	Volvo Trucks North America	Valiant TMS	Table of contents :	Drawing name:	=
Ed.	MKLEPADLO			&MFS=V1WR1UQ51UQ12+V1WR1UQ51/1 -	=2V08&MFS-PNEU	+
Appr		P6700 Side Skin Roof Outer - Cell 2V08		&MPB+KH0/1	Document type:	Project nr:
Modification	Date	Name	Original	Replacement of	MAB	22-16147
				Replaced by		Page 3
				Scale 1:1		112

# Table of contents

Column X: An automatically generated page was edited

F06\_001

Page	Page description	supplementary page field	Date	Edited by	X
&MPB+KH1/1	Parts list : FES.MSB9-AQR:C2:J73-WP-UL1 - FES.MSB9-AQT:C2:J73:F8-WP-UL1		1/4/2023	MKLEPADLO	
&MPB+V1AR11UQ41/1	Parts list : FES.51E-F33GCQPNMKBNMKBNMKB-D-UL1+GS2GZBA & 32P-TJQ-R-MBHBH-4J - FES.534658		1/4/2023	MKLEPADLO	
&MPB+V1AR11UQ42/1	Parts list : FES.51E-F33GCQPNMKBNMKBNMKB-D-UL1+GS2GZBA & 32P-TJQ-R-MBHBH-6J - FES.537953		1/4/2023	MKLEPADLO	
&MPB+V1AR11UQ43/1	Parts list : FES.51E-F33GCQPNMKBNMKBNMKB-D-UL1+GS2GZBA & 32P-TJQ-R-MBHBH-6J - FES.537953		1/4/2023	MKLEPADLO	
&MPB+V1AR201UQ41/1	Parts list : FES.51E-F33GCQPNMKBNMKB-D-UL1+GS2GZBA & 32P-TJQ-R-MBH-JJ - FES.537953		1/4/2023	MKLEPADLO	
&MPB+V1AR201UQ42/1	Parts list : FES.51E-F33GCQPNMKBNMKBNMKB-D-UL1+GS2GZBA & 32P-TJQ-R-MBHBH-4J - FES.537953		1/4/2023	MKLEPADLO	
&MPB+V1PF1/1	Parts list : FES.51E-F33GCQPNMKB-S-UL1+GS2GZBA & 45PN-R-Z-LSMX-BU-JL - FES.539212		1/4/2023	MKLEPADLO	
&MPB+V1WR1UQ51/1	Parts list : FES.51E-F33GCQPNMKBNMKBNMKB-S-UL1+GS2GZBA & 45PN-R-Z-LSMX-5BU-10SA - FES.534663		1/4/2023	MKLEPADLO	
&MPB+V1WR1UQ51/2	Parts list : FES.560727 - FES.534663		1/4/2023	MKLEPADLO	
&MPB+V1WR1UQ52/1	Parts list : FES.51E-F33GCQPNMKBNMKBNMKB-S-UL1+GS2GZBA & 45PN-R-Z-LSMX-5BU-10SA - FES.560727		1/4/2023	MKLEPADLO	
&MPB+V2LB1/1	Parts list : FES.51E-F33GCQPNMKBNMKBNMKB-S-UL1+GS2GZBA & 45PN-R-Z-LSMX-BU-SASA - FES.534663		1/4/2023	MKLEPADLO	
&MPB+V2WR1UQ51/1	Parts list : FES.51E-F33GCQPNMKBNMKBNMKB-S-UL1+GS2GZBA & 45PN-R-Z-LSMX-BBU-4J - FES.534666		1/4/2023	MKLEPADLO	
&MPB+V2WR1UQ52/1	Parts list : FES.51E-F33GCQPNMKBNMKBNMKB-S-UL1+GS2GZBA & 45PN-R-Z-LSMX-BBU-3JL - FES.539212		1/4/2023	MKLEPADLO	

Modification	Date	Name	Date	1/4/2023	Volvo Trucks North America		Valiant TMS	Table of contents : &MPB+KH1/1 - &MPB+V2WR1UQ52/1	Drawing name: =2V08&MFS-PNEU	=	
				MKLEPADLO	P6700 Side Skin Roof Outer - Cell 2V08		Scale 1:1		Document type: MAB	Project nr: 22-16147	+
					Replacement of		Replaced by				
									Page	4	
										112	

**A1**  
 535031  
 535025  
 541681  
 537133  
 8035544  
 572577  
 8030308

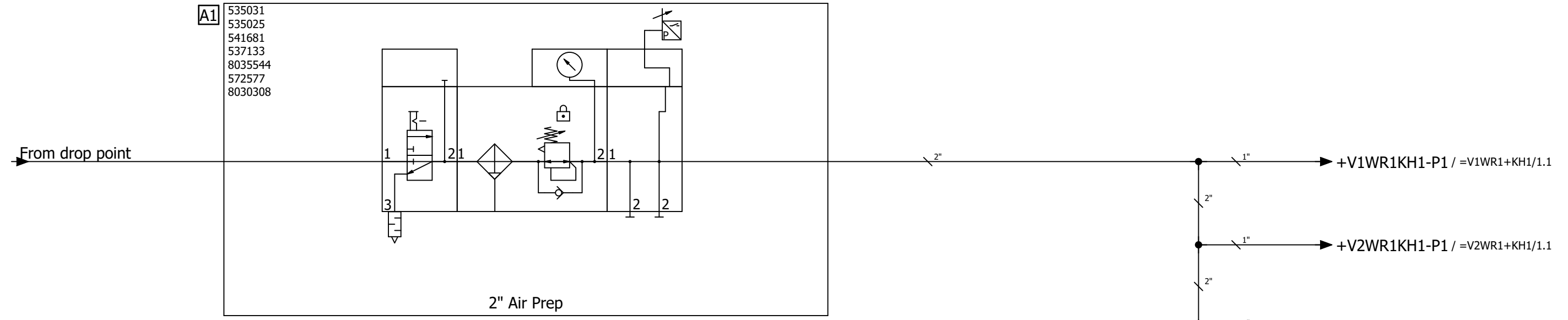

From drop point → 1" → +V2AR181XQ93KH1-P1 / =V2AR181XQ93+KH1/1.1  
 Fume Extractor

- 1" → +V1WR1KH1-P1 / =V1WR1+KH1/1.1
- 2" → 1" → +V2WR1KH1-P1 / =V2WR1+KH1/1.1
- 2" → 1" → +V2LB1KH1-P1 / =V2LB1+KH1/1.1  
Laser Booth
- 2" → 1/2" → +V1PF1KH1-P1 / =V1PF1+KH1/1.1  
Date Scribe
- 2" → 1/2" → +V1GM1KH1-P1 / =V1GM1+KH1/1.1  
Lift Assist
- 2" → 1/2" → +V1GM2KH1-P1 / =V1GM2+KH1/1.1  
Lift Assist
- 1/2" → V1AR11 /  
Robot Media Panel
- 1/2" → V1AR201 /  
Robot Media Panel

=V1AR11UQ41KF1+V1AR11UQ41/1

&MAB+/4			Date	1/4/2023	Volvo Trucks North America	Valiant TMS	Incoming air supply	Drawing name:		= KH0
			Ed.	MKLEPADLO				=2V08&MFS-PNEU		+ KH0
			Appr		P6700 Side Skin Roof Outer - Cell 2V08	Scale 1:1		Document type:	Project nr:	Page
Modification	Date	Name	Original		Replacement of			Replaced by	MFS	22-16147
										112

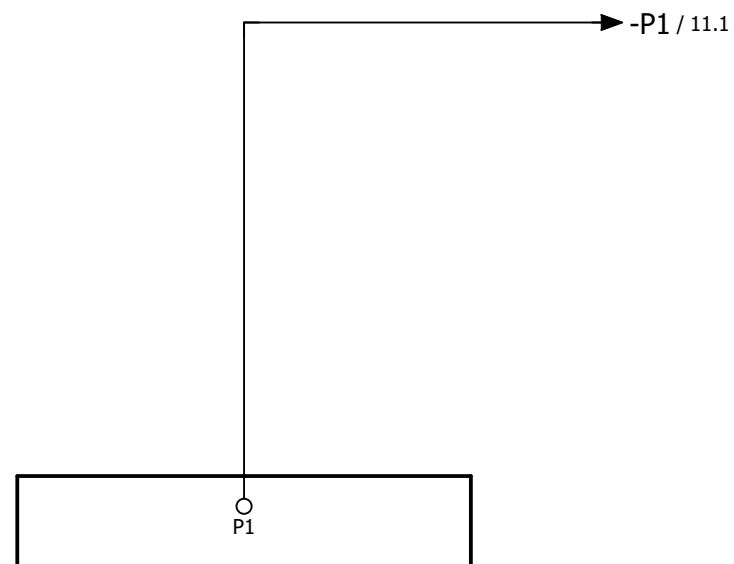

=KH0+KH0/1

		Date	1/4/2023	Volvo Trucks North America			Valiant TMS	AIR SUPPLY GRIPPER	Drawing name:		= V1AR11UQ41KF1
		Ed.	MKLEPADLO	P6700 Side Skin Roof Outer - Cell 2V08					=2V08&MFS-PNEU		+ V1AR11UQ41
Modification	Date	Name	Original	Replacement of	Replaced by		Scale 1:1		Document type:	Project nr:	Page
									MFS	22-16147	1
											112



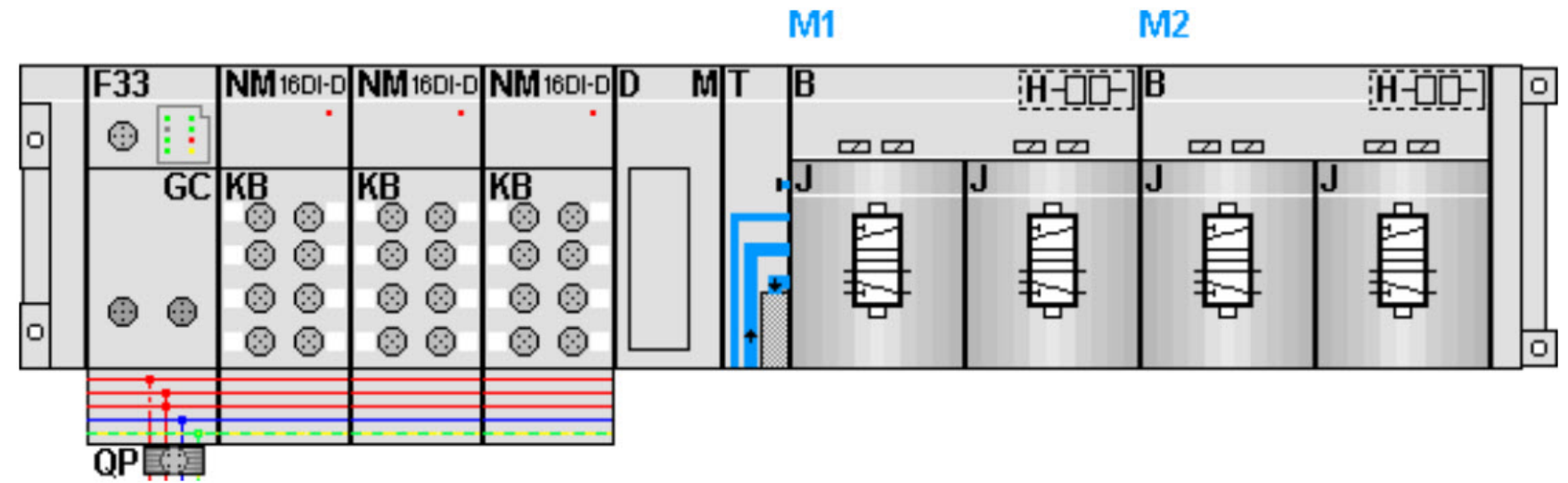

KF1.0

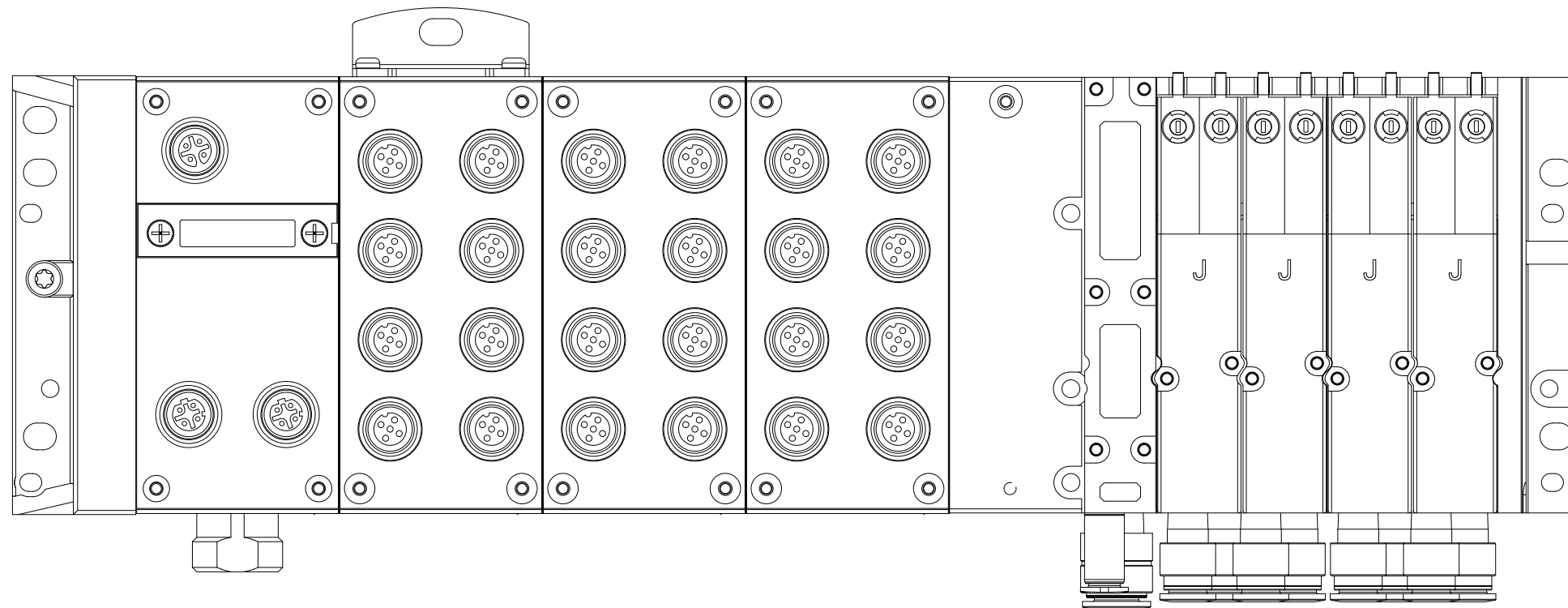

Date		1/4/2023		Volvo Trucks North America		Valiant TMS		AIR SUPPLY		Drawing name:		= V1AR11UQ41KF1	
Ed.		MKLEPADLO		P6700 Side Skin Roof Outer - Cell 2V08		Scale 1:1				Document type:		= 2V08&MFS-PNEU	
Appr.				Replacement of		Replaced by				Project nr:		+ V1AR11UQ41	
Modification	Date	Name	Original							MFS	22-16147	Page	5
													112





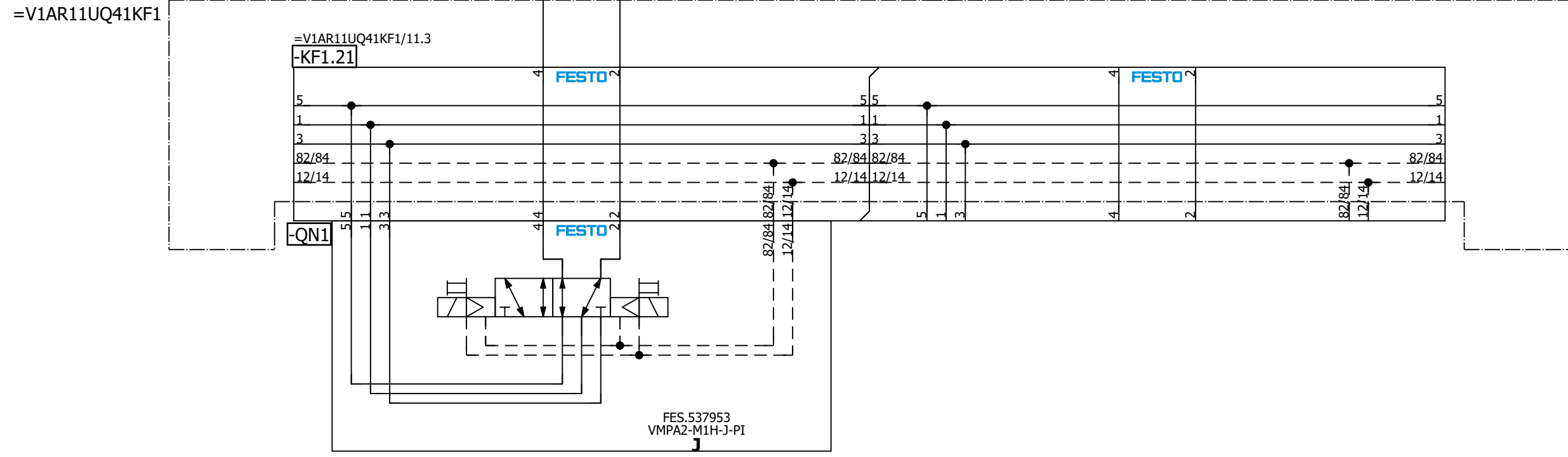
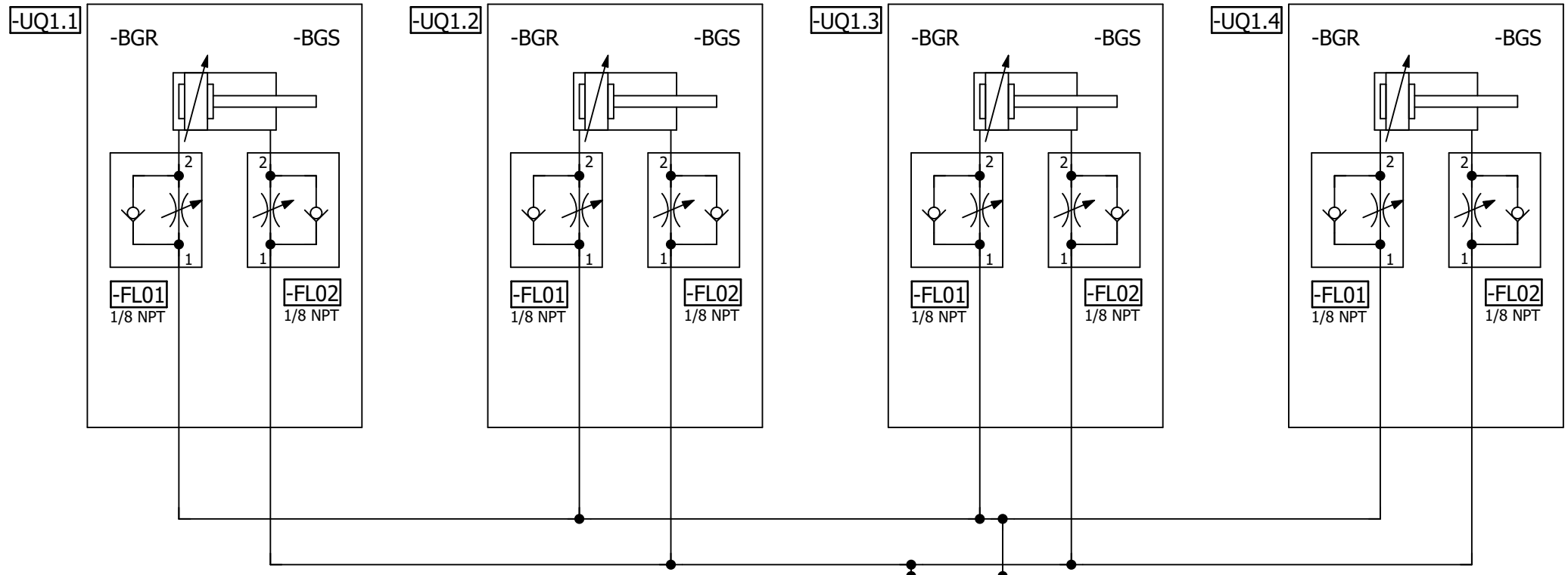

=V1AR11UQ41  
-UQ1-QN1.1  
Clamps 1  
(RST)

=V1AR11UQ41  
-UQ1-QN1.2  
Clamps 1  
(SET)

=V1AR11UQ41KF1/11

=V1AR11UQ41UQ2/1

Date		1/4/2023		Volvo Trucks North America		Valiant TMS		Clamps 1		Drawing name:		= V1AR11UQ41UQ1	
Ed.		MKLEPADLO		P6700 Side Skin Roof Outer - Cell 2V08		Scale 1:1				Document type:		= 2V08&MFS-PNEU	
Appr				Replacement of		Replaced by				Project nr:		+ V1AR11UQ41	
Original										MFS		Page 1	
										22-16147		112	



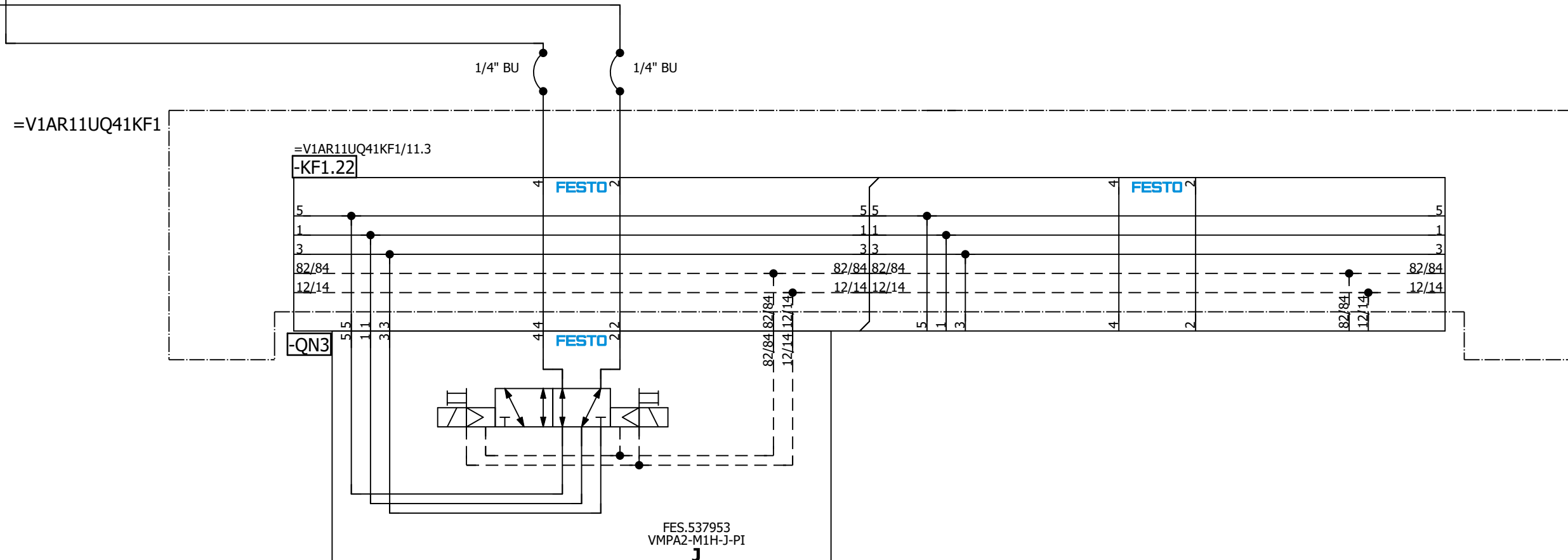
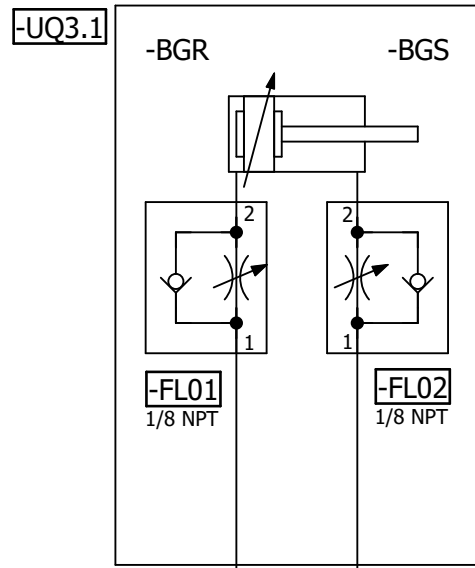

=V1AR11UQ41  
-UQ3-QN3.1  
Clamp 3  
(RST)

=V1AR11UQ41  
-UQ3-QN3.2  
Clamp 3  
(SET)

=V1AR11UQ41UQ2/1

=V1AR11UQ41UQ4/1

Date: 1/4/2023		Volvo Trucks North America		Valiant TMS		Clamp 3		Drawing name: =V1AR11UQ41UQ3		= V1AR11UQ41UQ3	
Ed.: MKLEPADLO		P6700 Side Skin Roof Outer - Cell 2V08		Scale 1:1		Document type: MFS		Project nr: 22-16147		+ V1AR11UQ41	
Appr:		Replacement of								Replaced by	
Modification	Date	Name	Original					Page 1		112	

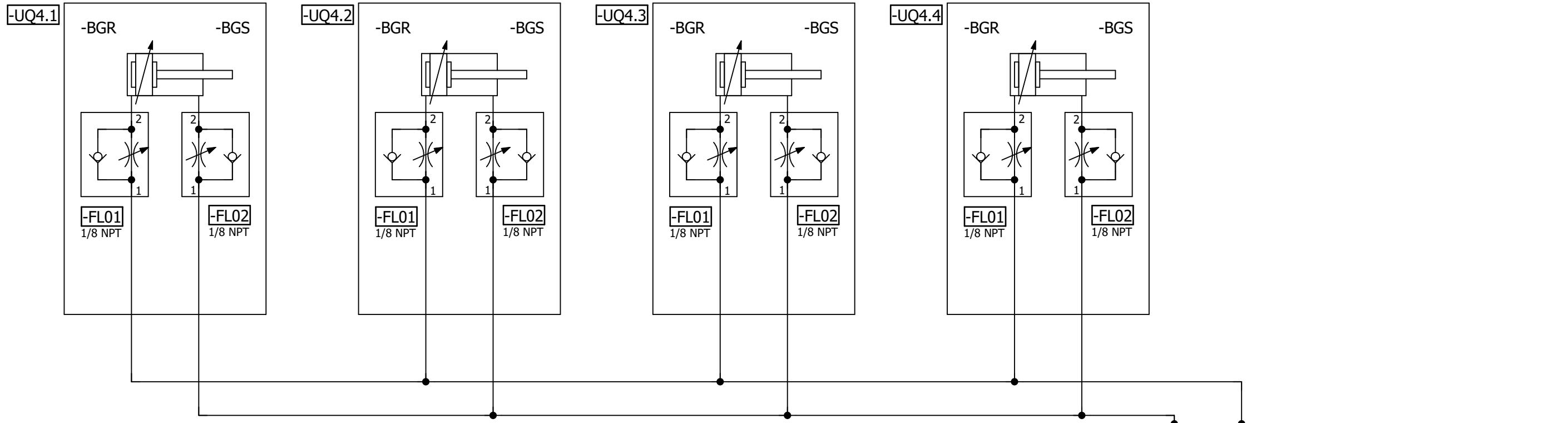

=V1AR11UQ41KF1

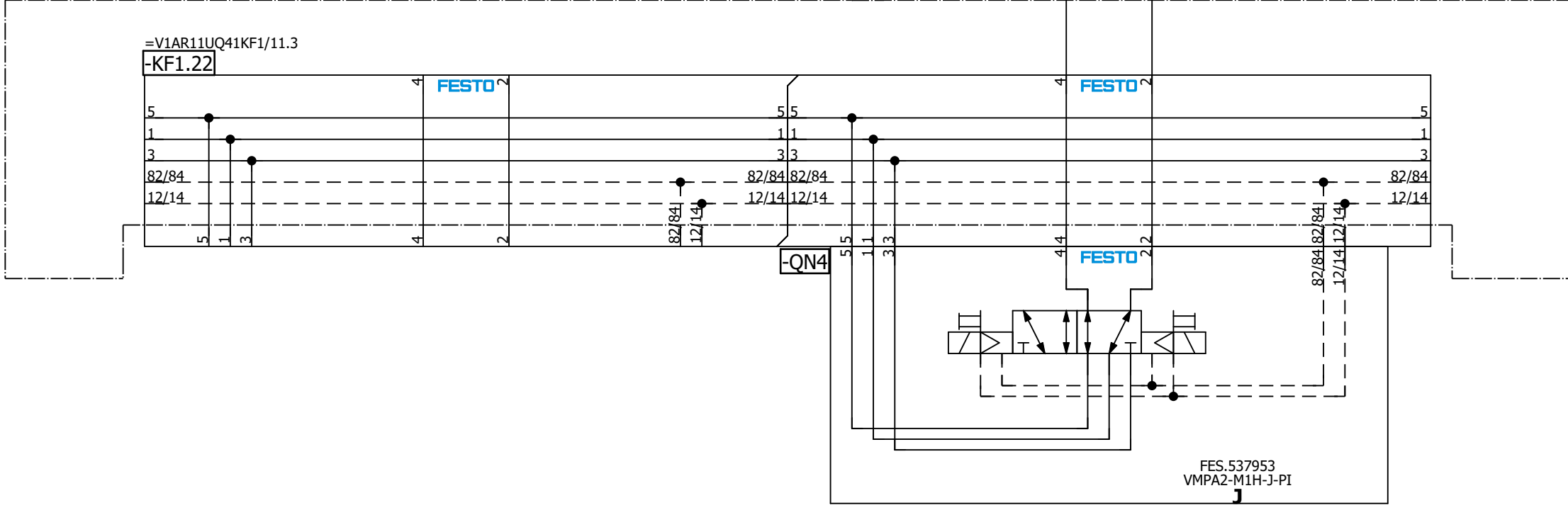

=V1AR11UQ41  
-UQ4-QN4.1  
Clamps 4  
(RST)

=V1AR11UQ41  
-UQ4-QN4.2  
Clamps 4  
(SET)

=V1AR11UQ42KF1+.AR11UQ42/1

=V1AR11UQ41UQ3/1

		Date	1/4/2023	Volvo Trucks North America		Valiant TMS	Clamps 4	Drawing name: =2V08&MFS-PNEU		= V1AR11UQ41UQ4 + V1AR11UQ41	
		Ed.	MKLEPADLO	P6700 Side Skin Roof Outer - Cell 2V08				Document type: MFS		Project nr: 22-16147	
Modification	Date	Name	Original	Replacement of	Replaced by	Scale 1:1				Page	1
											112

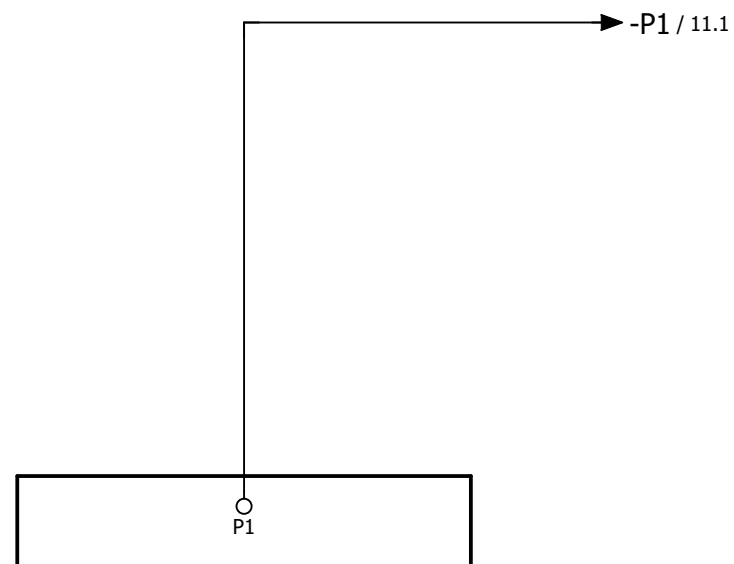

=V1AR11UQ41UQ4+.AR11UQ41/1

		Date	1/4/2023	Volvo Trucks North America			Valiant TMS	AIR SUPPLY GRIPPER	Drawing name:		= V1AR11UQ42KF1
		Ed.	MKLEPADLO	P6700 Side Skin Roof Outer - Cell 2V08					=2V08&MFS-PNEU		+ V1AR11UQ42
		Appr		Replacement of		Replaced by	Scale 1:1		Document type:	Project nr:	Page
Modification	Date	Name	Original						MFS	22-16147	1
											112



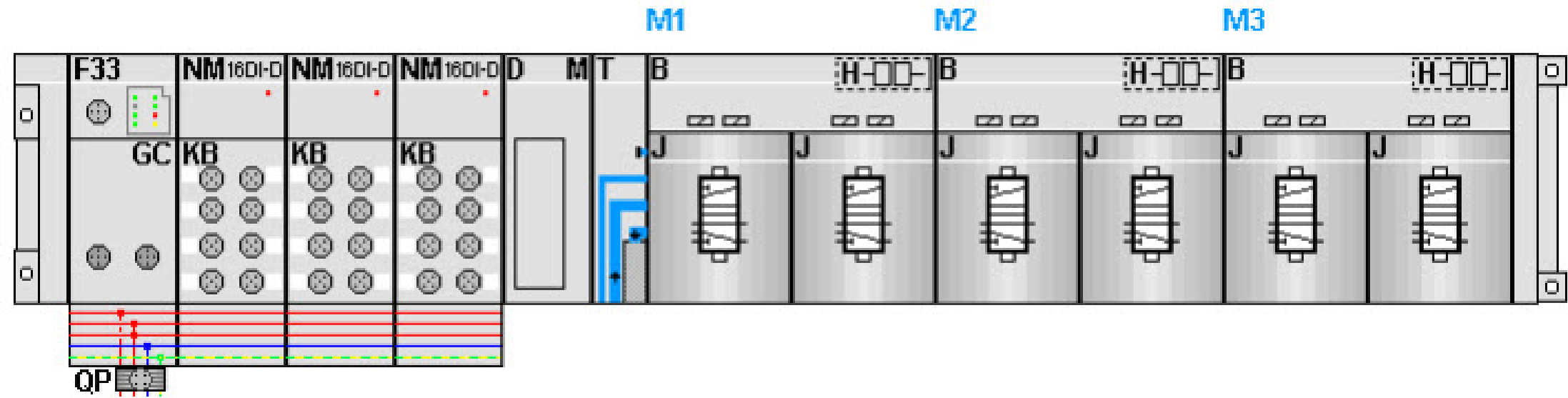

KF1.0

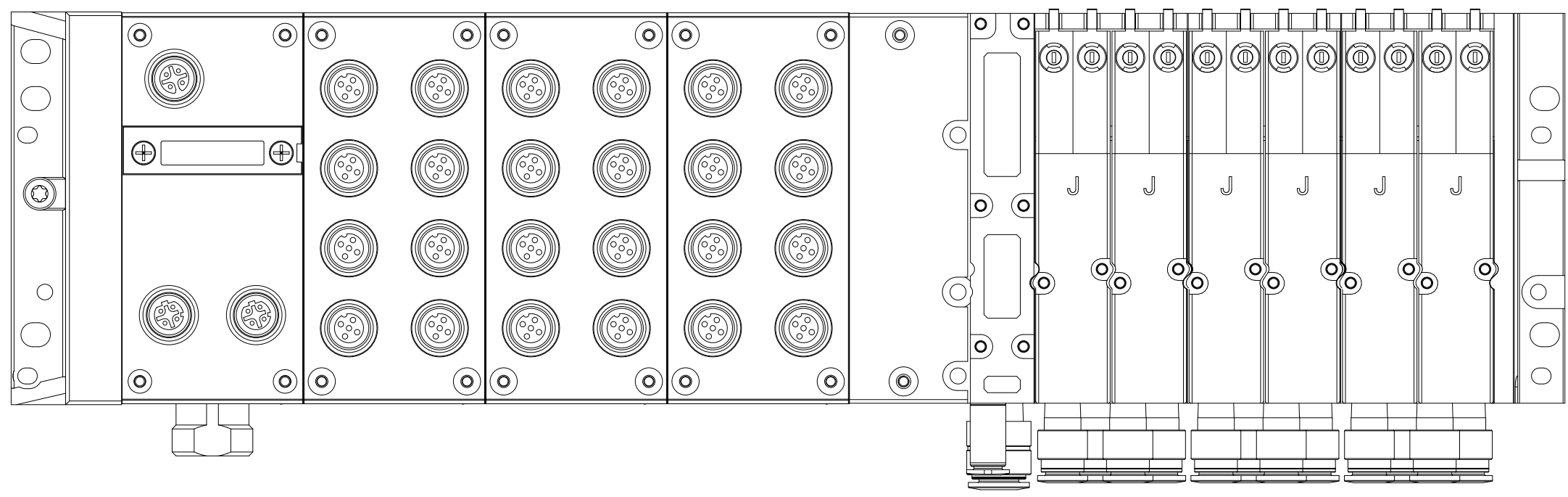

Date		1/5/2023		Volvo Trucks North America		Valiant TMS		AIR SUPPLY		Drawing name:		= V1AR11UQ42KF1	
Ed.		MKLEPADLO		P6700 Side Skin Roof Outer - Cell 2V08		Scale 1:1				Document type:		+ V1AR11UQ42	
Appr				Replacement of		Replaced by				Project nr:		Page	
Original										22-16147		5	
Modification		Date		Name						MFS		112	

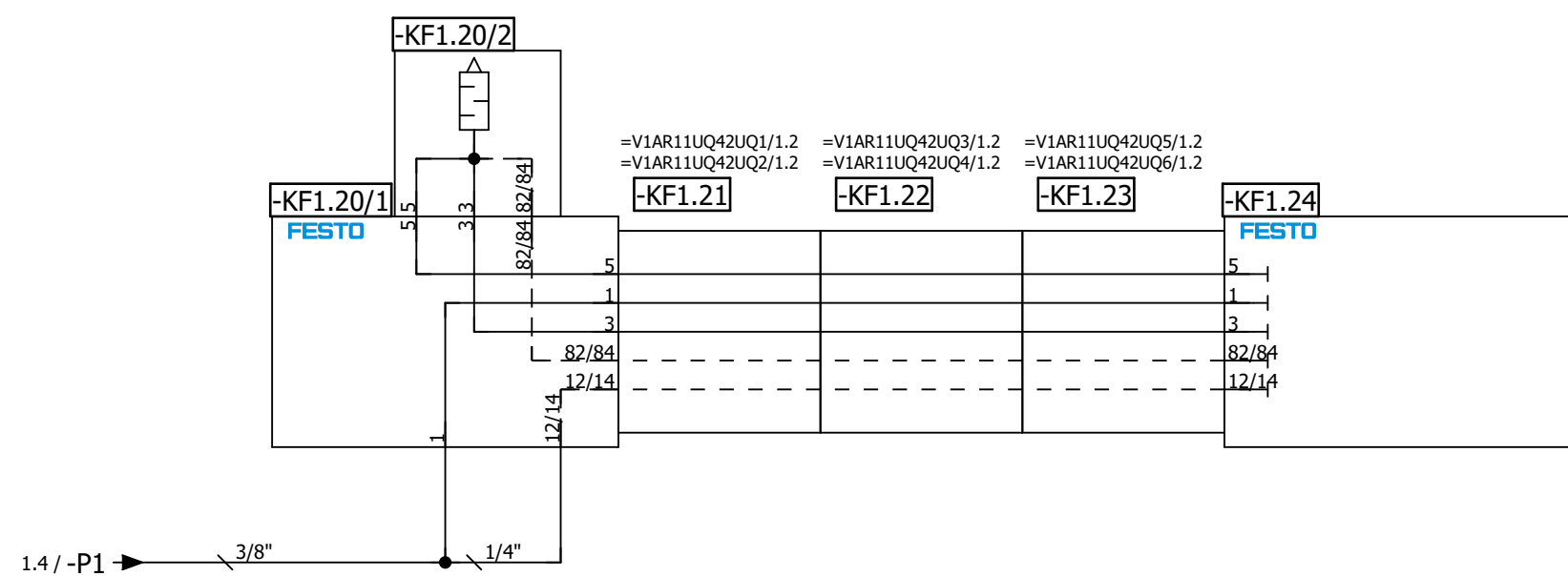
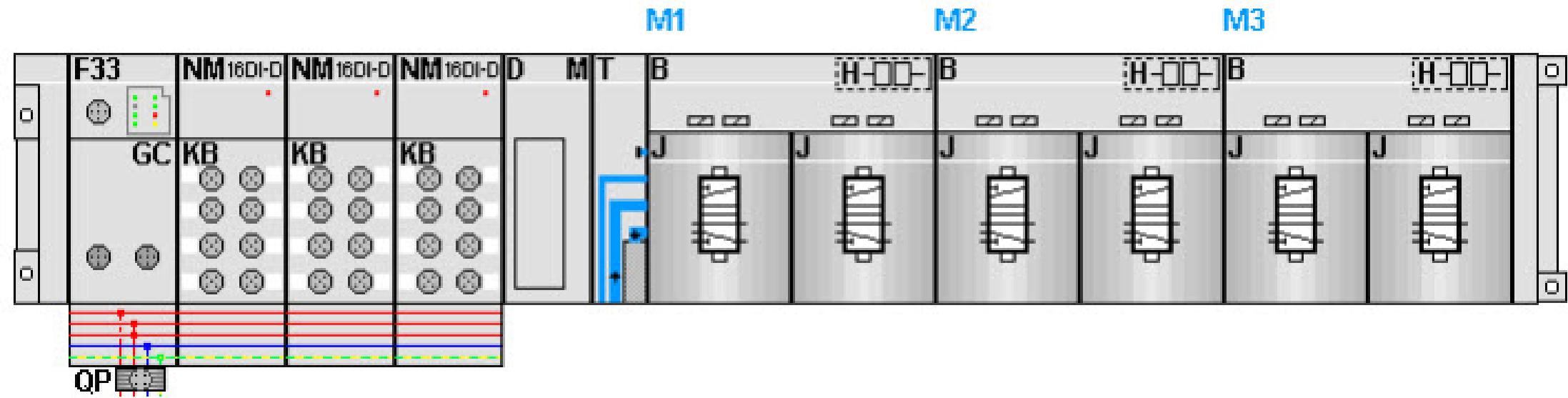

Date		1/4/2023	Volvo Trucks North America		Valiant TMS	AIR SUPPLY	Drawing name:		= V1AR11UQ42KF1
Ed.		MKLEPADLO	P6700 Side Skin Roof Outer - Cell 2V08				=2V08&MFS-PNEU		+ V1AR11UQ42
Appr			Replacement of		Scale 1:1		Document type:	Project nr:	Page
Modification	Date	Name	Original	Replaced by			MFS	22-16147	11

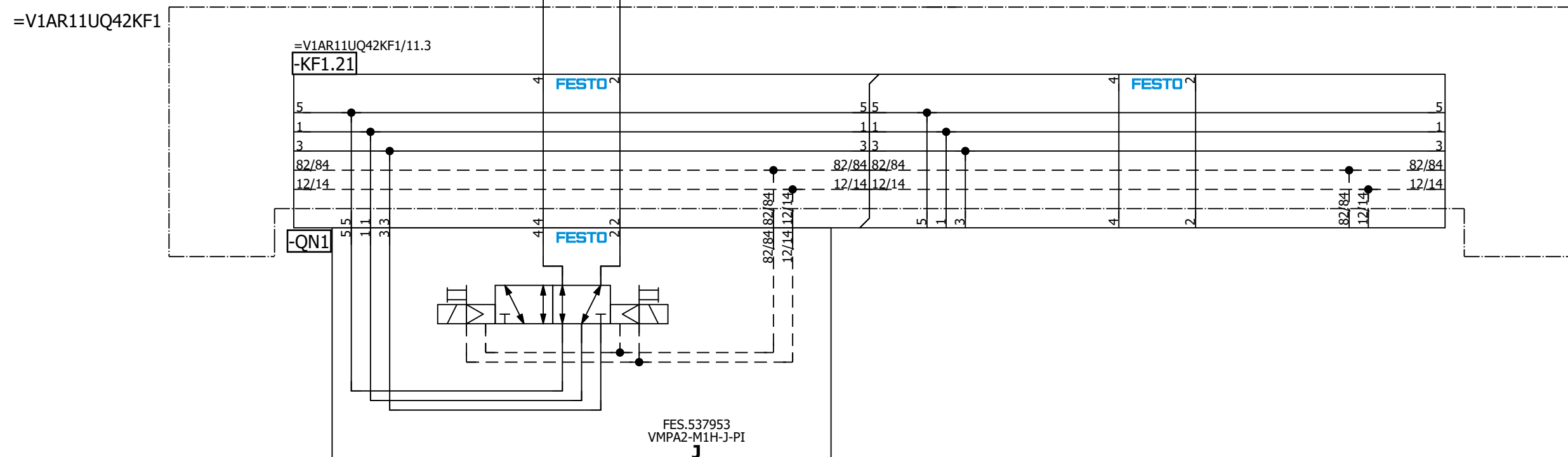
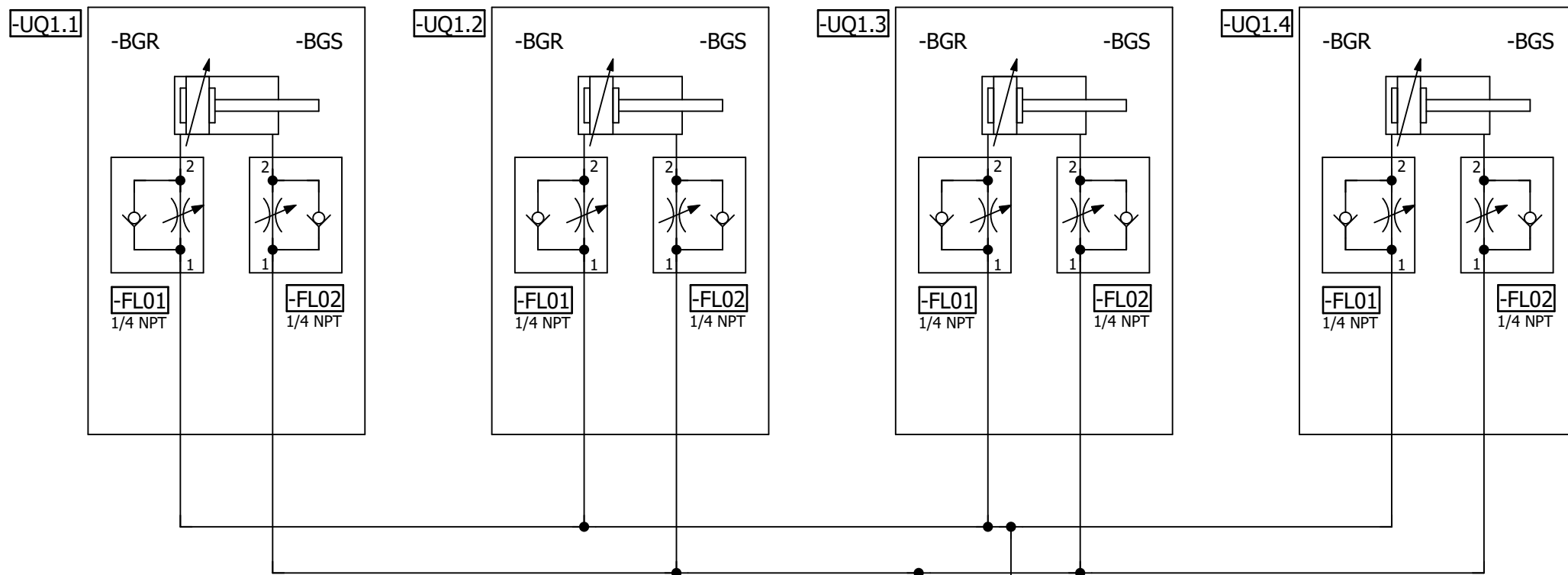

=V1AR11UQ42  
-UQ1-QN1.1  
Clamps 1  
(RST)

=V1AR11UQ42  
-UQ1-QN1.2  
Clamps 1  
(SET)

=V1AR11UQ42KF1/11

=V1AR11UQ42UQ2/1

		Date	1/4/2023	Volvo Trucks North America		Valiant TMS		Clamps 1		Drawing name: =2V08&MFS-PNEU		= V1AR11UQ42UQ1 + V1AR11UQ42	
		Ed.	MKLEPADLO	P6700 Side Skin Roof Outer - Cell 2V08				Scale 1:1		Document type: MFS		Project nr: 22-16147	
Modification	Date	Name	Original	Replacement of	Replaced by					Page 1		112	

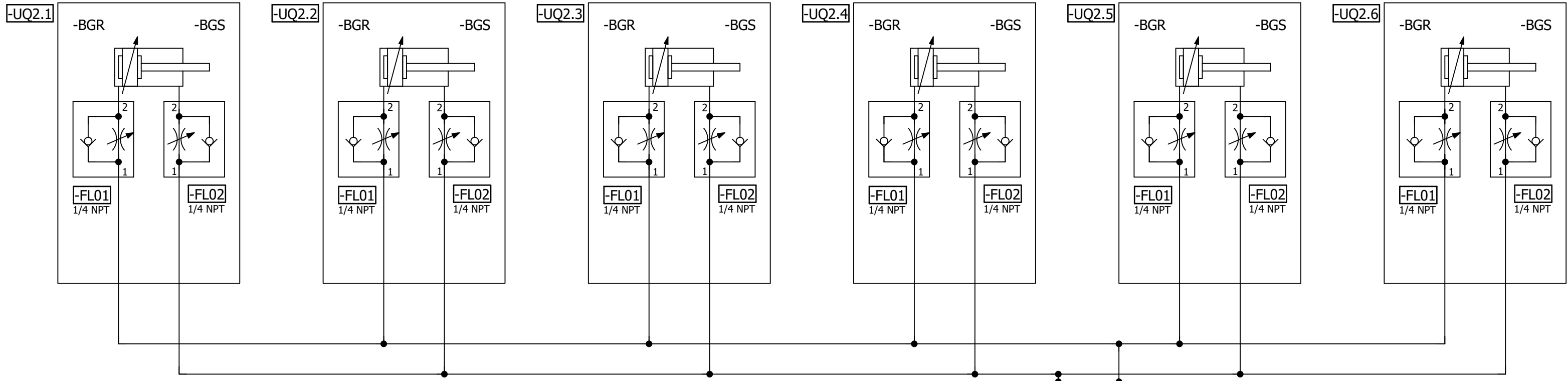

1/4" BU 1/4" BU

=V1AR11UQ42KF1

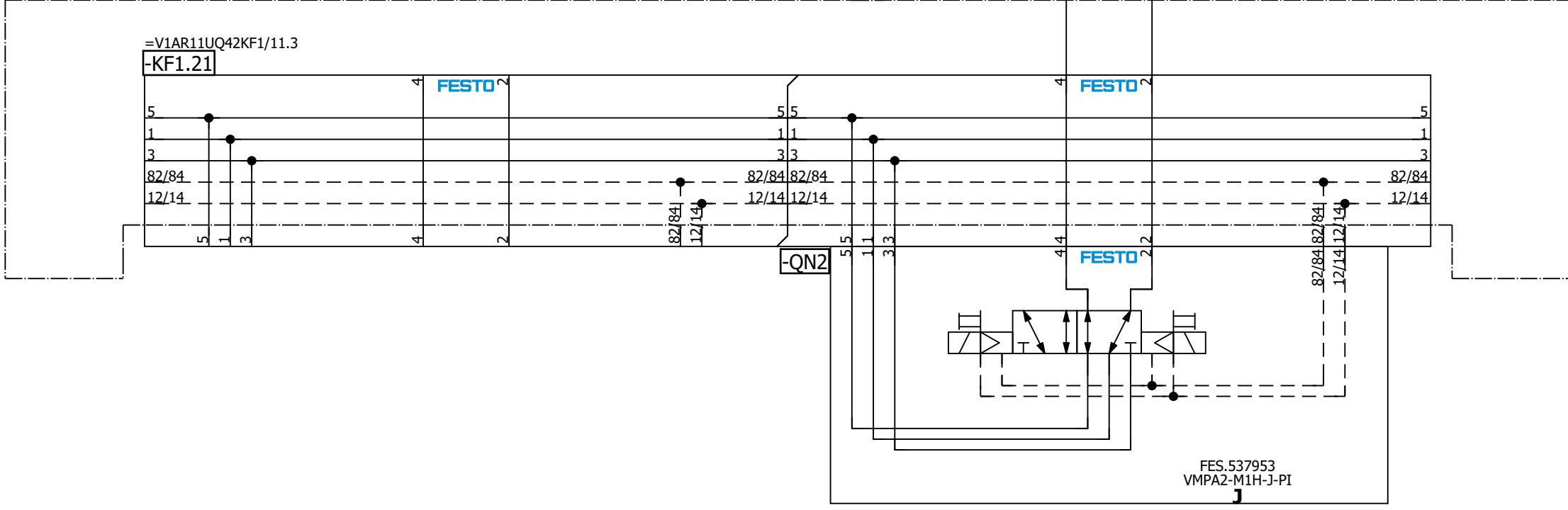

=V1AR11UQ42  
-UQ2-QN2.1  
Clamps 2  
(RST)

=V1AR11UQ42  
-UQ2-QN2.2  
Clamps 2  
(SET)

=V1AR11UQ42UQ1/1

=V1AR11UQ42UQ3/1

Volvo Trucks North America		Valiant TMS		Clamps 2		Drawing name: =2V08&MFS-PNEU		= V1AR11UQ42UQ2 + V1AR11UQ42	
P6700 Side Skin Roof Outer - Cell 2V08		Scale 1:1				Document type: MFS		Project nr: 22-16147	
Modification	Date	Name	Original	Replacement of	Replaced by			Page	1
									112



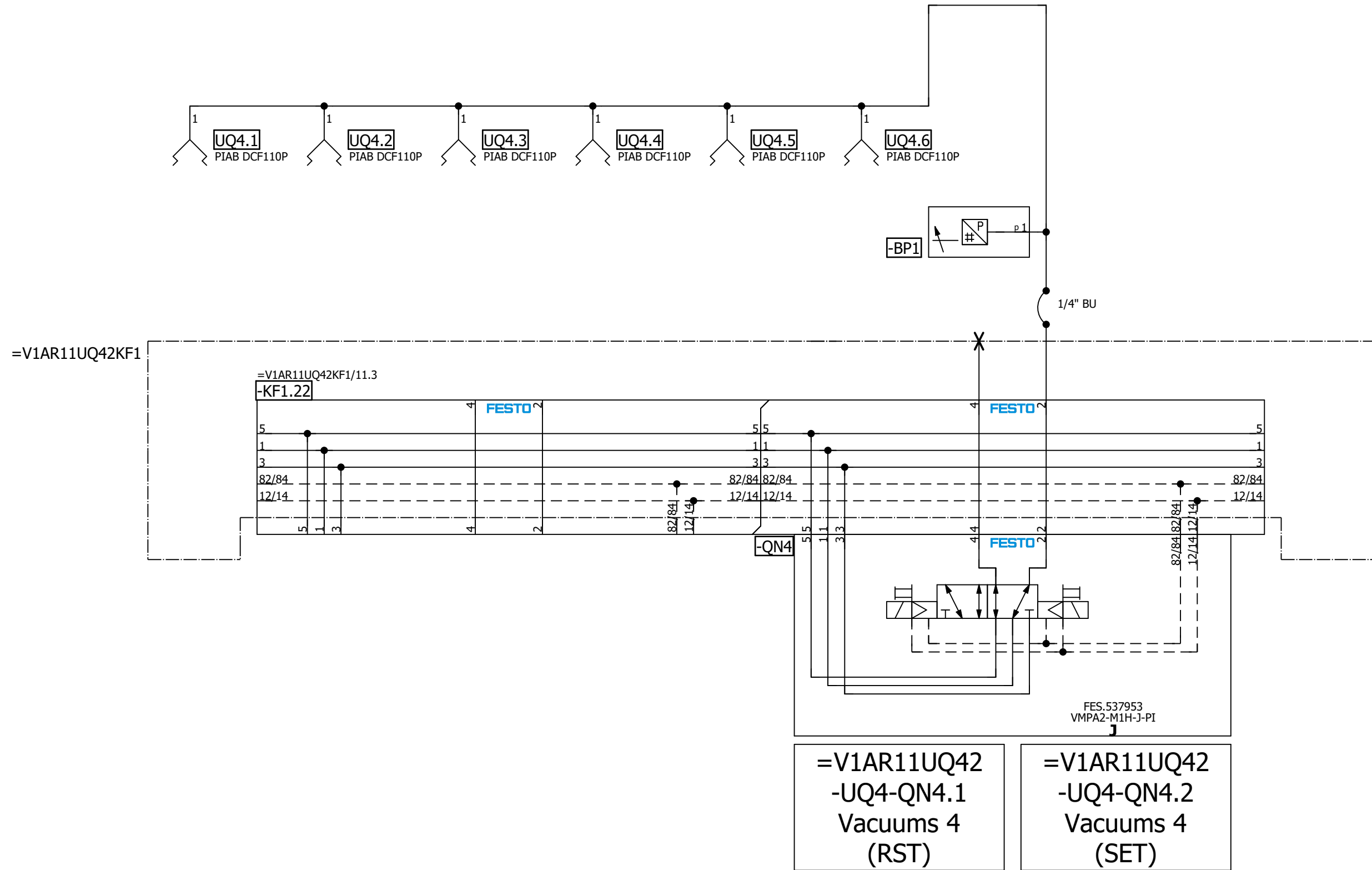

=V1AR11UQ42UQ3/1

=V1AR11UQ42UQ5/1

Date		1/4/2023		Volvo Trucks North America		Valiant TMS		Vacuums 4		Drawing name:		= V1AR11UQ42UQ4	
Ed.		MKLEPADLO		P6700 Side Skin Roof Outer - Cell 2V08		Scale 1:1				Document type:		+ V1AR11UQ42	
Appr.				Replacement of		Replaced by				Project nr:		Page 1	
Modification		Date		Name		Original				MFS		22-16147	
												112	



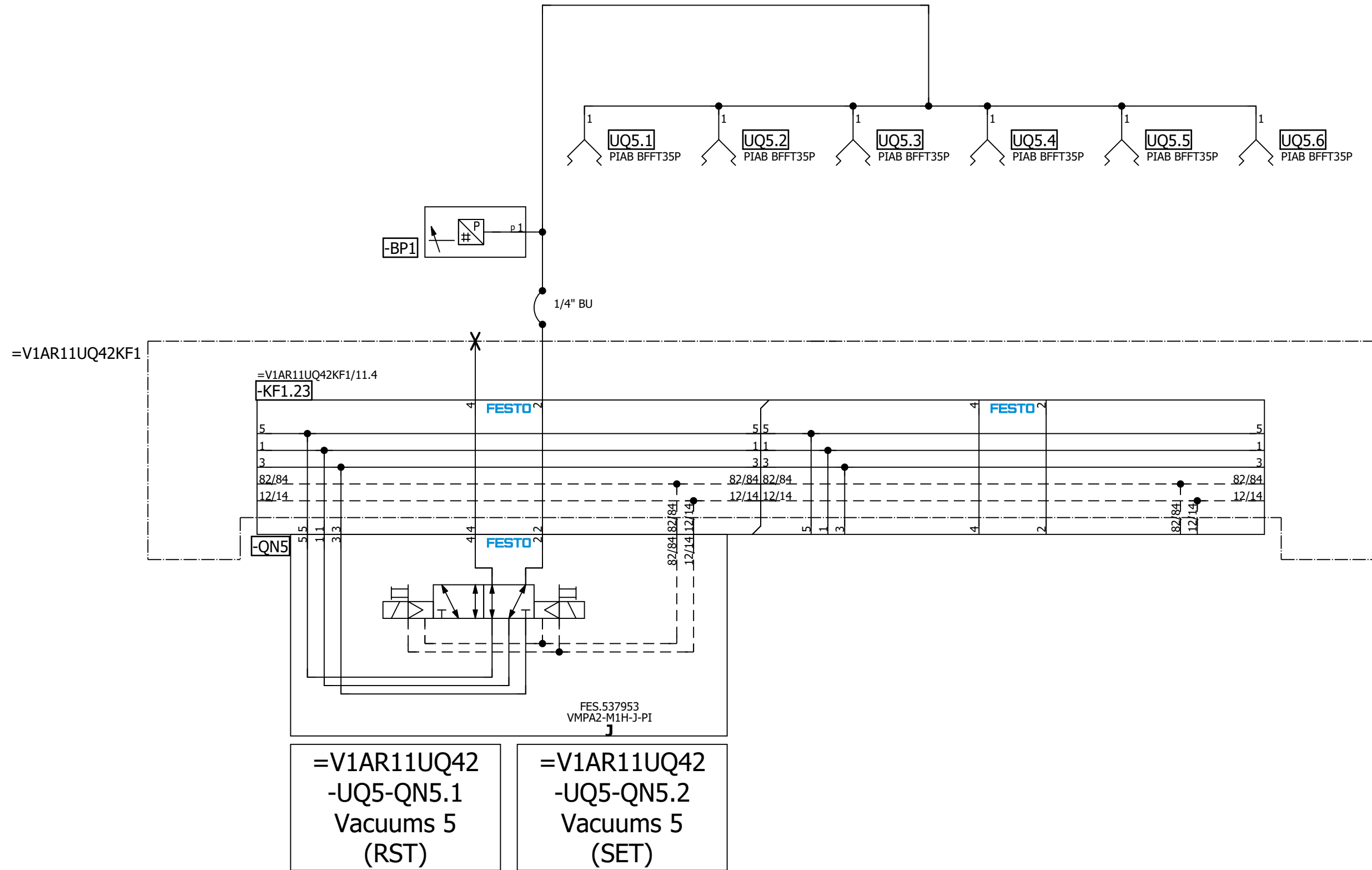

**=V1AR11UQ42**  
**-UQ5-QN5.1**  
**Vacuums 5**  
**(RST)**

**=V1AR11UQ42**  
**-UQ5-QN5.2**  
**Vacuums 5**  
**(SET)**

=V1AR11UQ42UQ4/1

=V1AR11UQ42UQ6/1

Date		1/4/2023	Volvo Trucks North America		Valiant TMS		Vacuums 5		Drawing name:		= V1AR11UQ42UQ5	
Ed.		MKLEPADLO	P6700 Side Skin Roof Outer - Cell 2V08		Scale 1:1				=2V08&MFS-PNEU		+ V1AR11UQ42	
Appr.			Replacement of		Replaced by				Document type:		Project nr:	
Original									MFS		22-16147	
Modification		Date	Name		Original						Page	
											1	
											112	

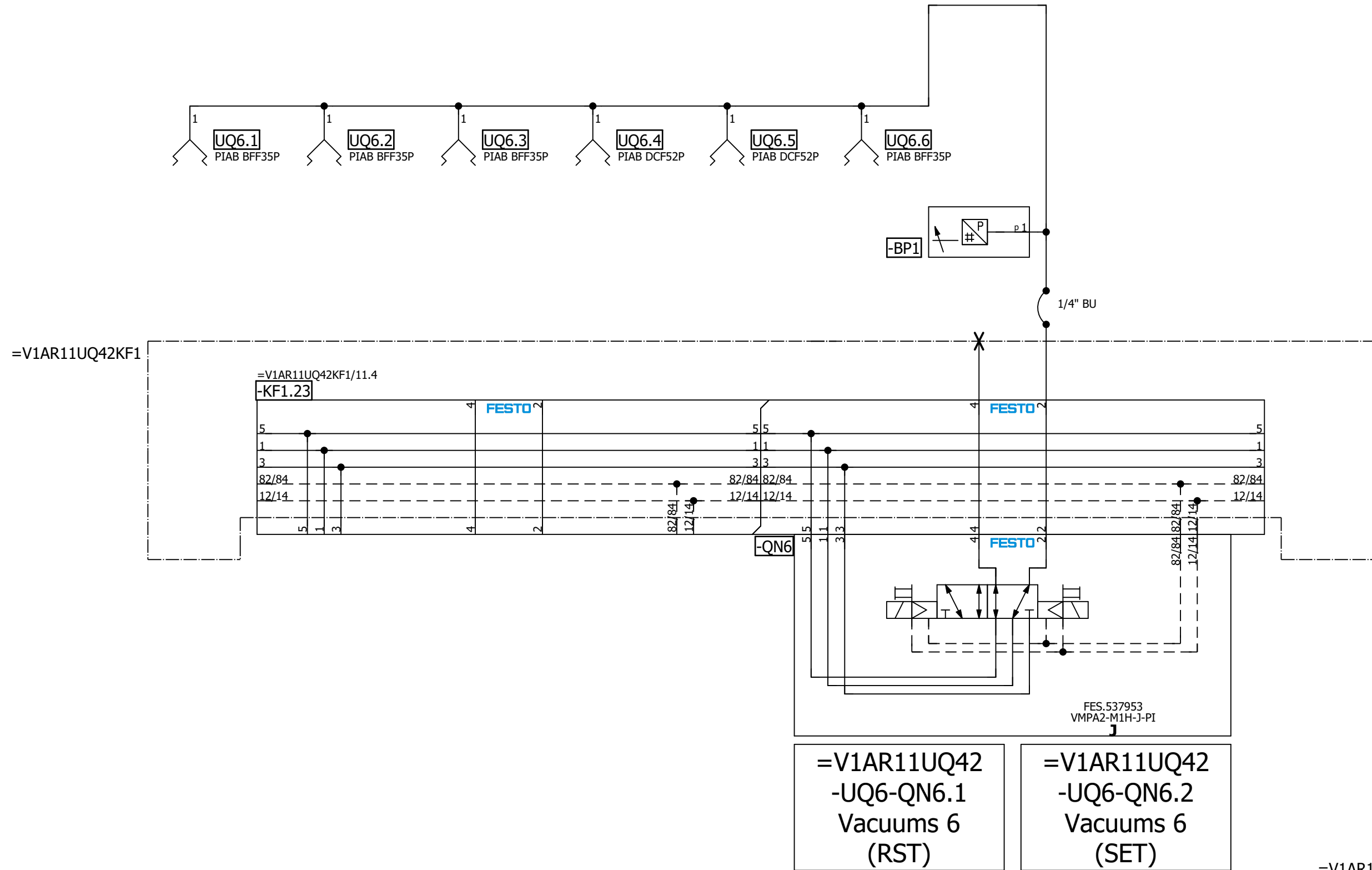

=V1AR11UQ42UQ5/1

Date		1/4/2023		Volvo Trucks North America		Valiant TMS		Vacuums 6		Drawing name:		= V1AR11UQ42UQ6	
Ed.		MKLEPADLO		P6700 Side Skin Roof Outer - Cell 2V08		Scale 1:1				Document type:		= V1AR11UQ42	
Appr.				Replacement of		Replaced by				Project nr:		Page 1	
Modification		Date		Name		Original				MFS		22-16147	
												112	

=V1AR11UQ43KF1+.AR11UQ43/1

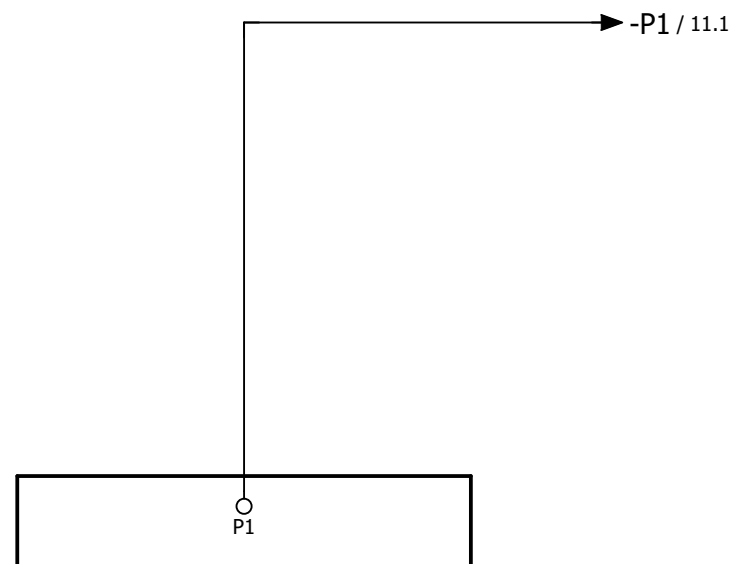

=V1AR11UQ42UQ6+.AR11UQ42/1

		Date	1/4/2023	Volvo Trucks North America			Valiant TMS	AIR SUPPLY GRIPPER	Drawing name: =2V08&MFS-PNEU		= V1AR11UQ43KF1	
		Ed.	MKLEPADLO	P6700 Side Skin Roof Outer - Cell 2V08					Document type: MFS		Project nr: 22-16147	
Modification	Date	Name	Original	Replacement of	Replaced by		Scale 1:1					112

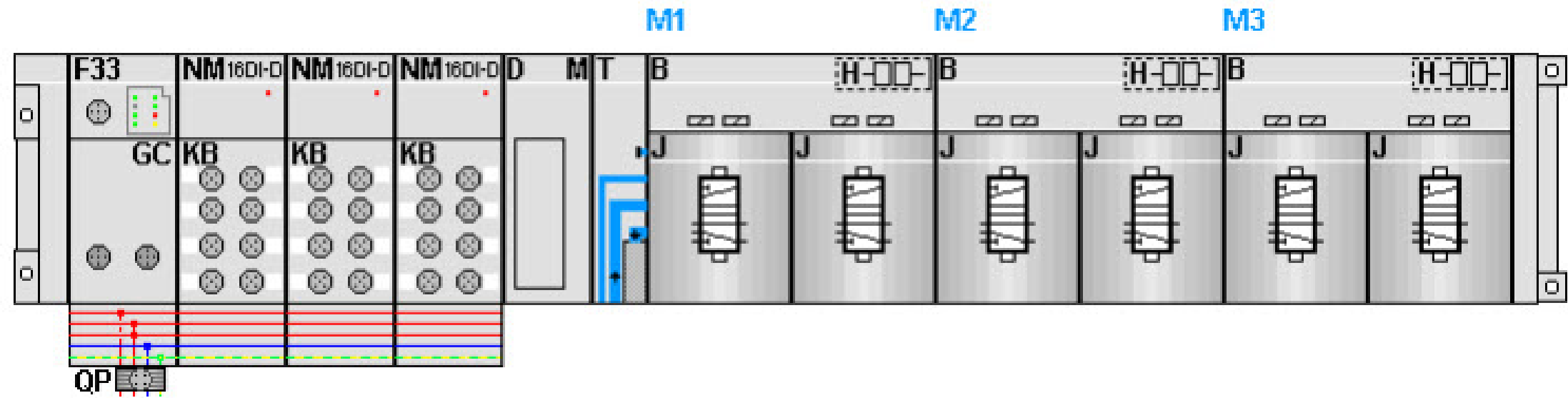

KF1.0

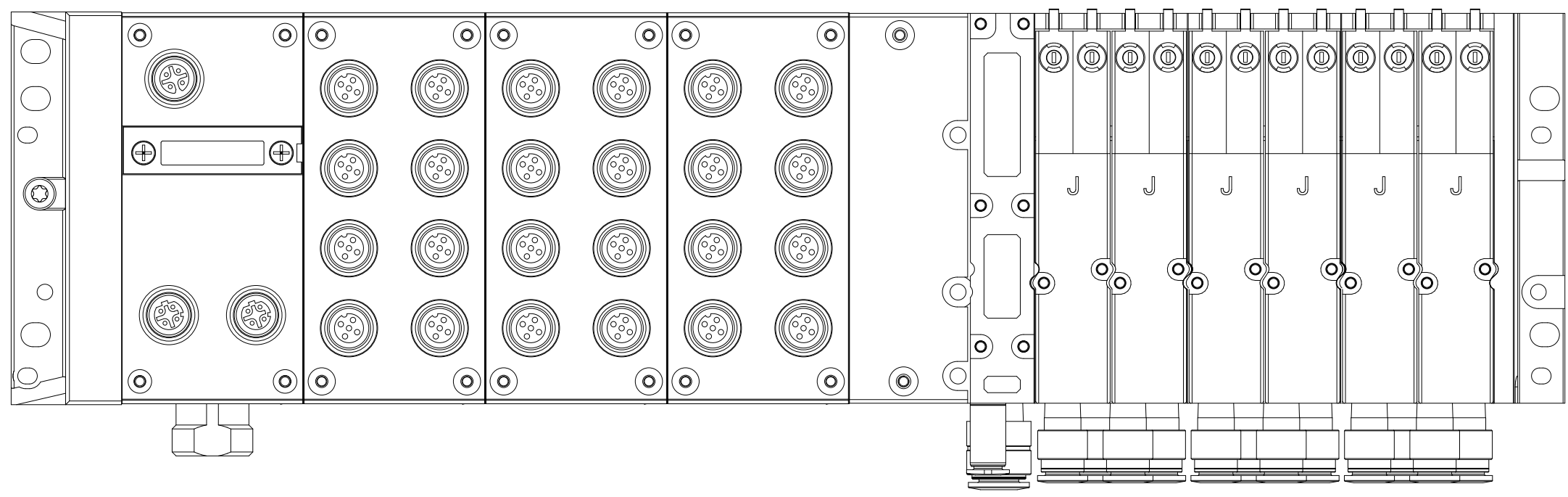

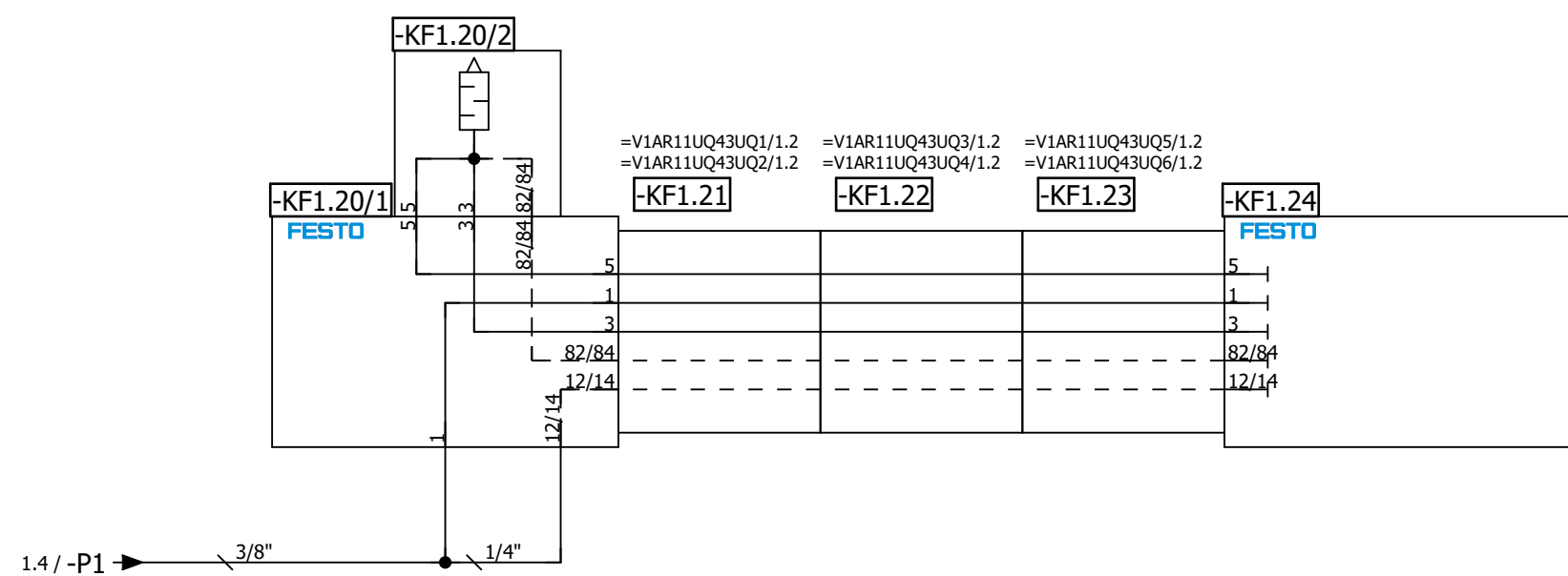
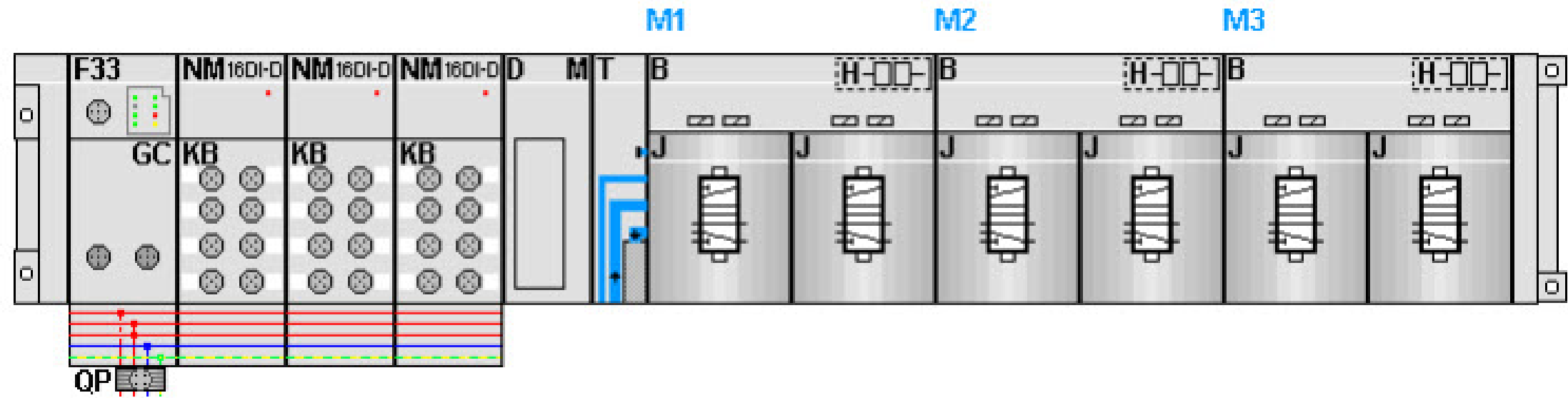

Date		1/4/2023	Volvo Trucks North America		Valiant TMS	AIR SUPPLY	Drawing name:		= V1AR11UQ43KF1			
Ed.		MKLEPADLO	P6700 Side Skin Roof Outer - Cell 2V08				=2V08&MFS-PNEU		+ V1AR11UQ43			
Appr			Replacement of		Scale 1:1	Document type:		MFS	Project nr:	22-16147	Page	11
Original			Replaced by			MFS		22-16147		Page	112	

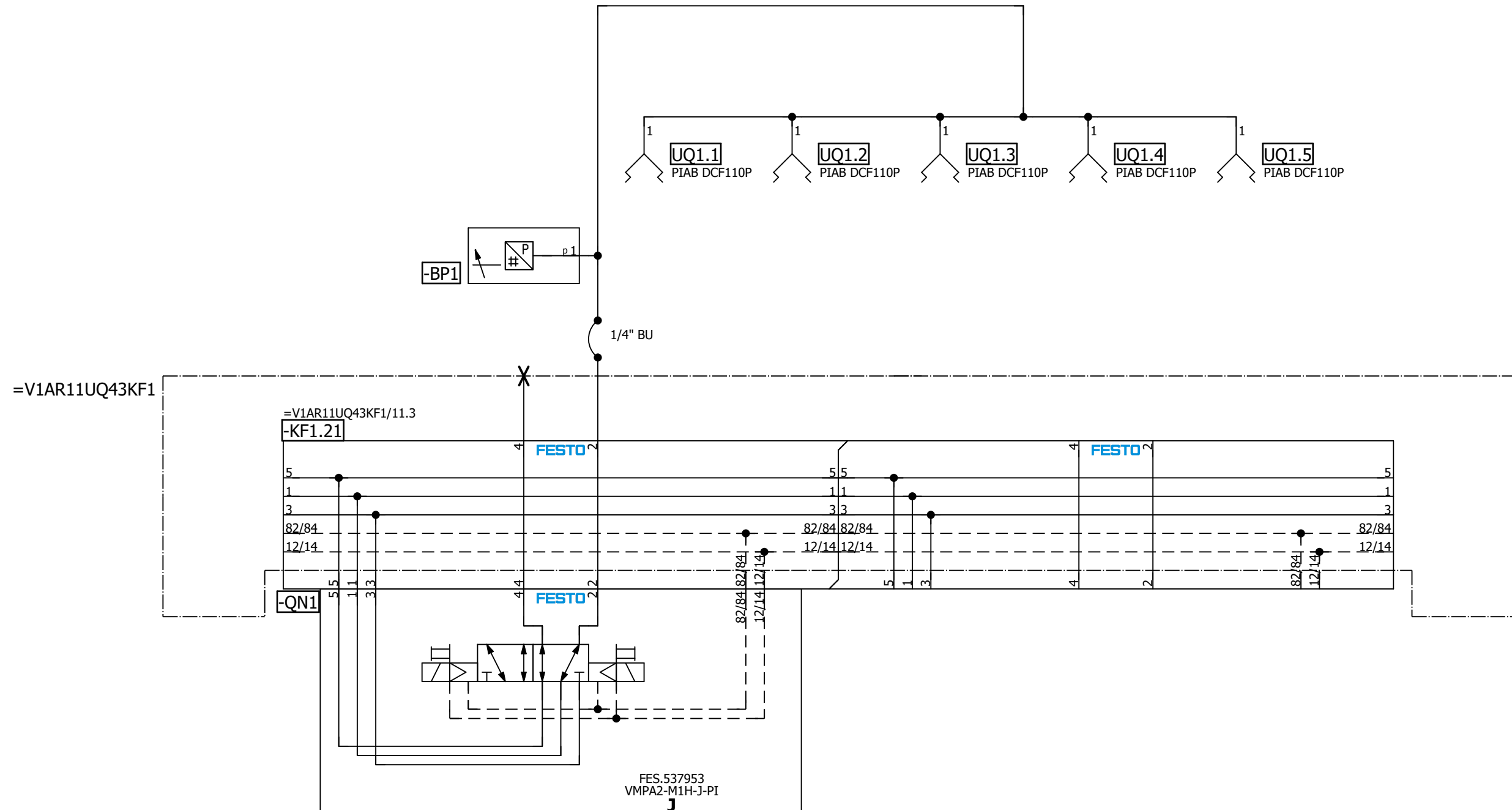

=V1AR11UQ43  
-UQ1-QN1.1  
Vacuums 1  
(RST)

=V1AR11UQ43  
-UQ1-QN1.2  
Vacuums 1  
(SET)

=V1AR11UQ43KF1/11

=V1AR11UQ43UQ2/1

Date		1/4/2023		Volvo Trucks North America		Valiant TMS		Vacuums 1		Drawing name:		= V1AR11UQ43UQ1	
Ed.		MKLEPADLO		P6700 Side Skin Roof Outer - Cell 2V08		Scale 1:1				Document type:		= 2V08&MFS-PNEU	
Appr.				Replacement of		Replaced by				Project nr:		+ V1AR11UQ43	
Modification		Date		Name		Original				MFS		Page 1	
										22-16147		112	



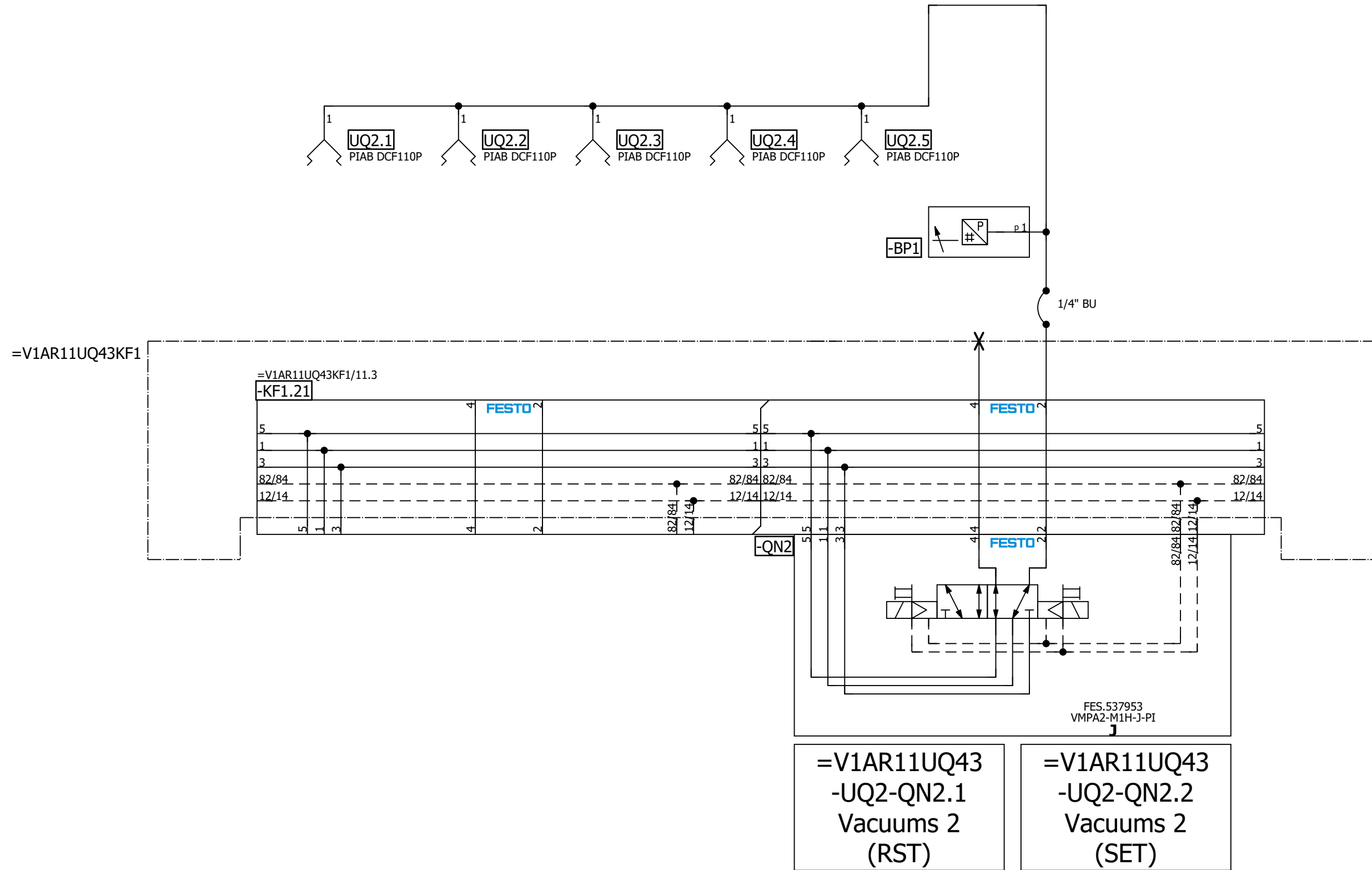

=V1AR11UQ43UQ1/1

=V1AR11UQ43UQ3/1

Date		1/4/2023	Volvo Trucks North America		Valiant TMS	Vacuums 2	Drawing name:		= V1AR11UQ43UQ2
Ed.		MKLEPADLO	P6700 Side Skin Roof Outer - Cell 2V08				=2V08&MFS-PNEU		+ V1AR11UQ43
Appr.			Replacement of		Scale 1:1		Document type:		Project nr:
Original			Replaced by				MFS	22-16147	
									1
									112





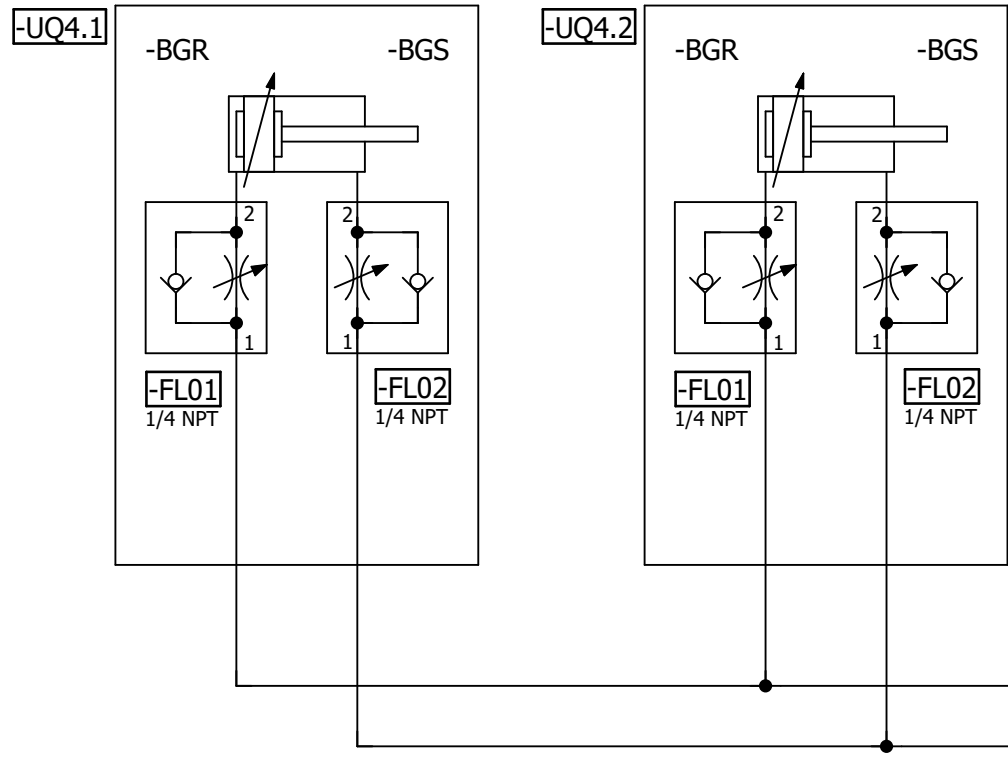

=V1AR11UQ43KF1

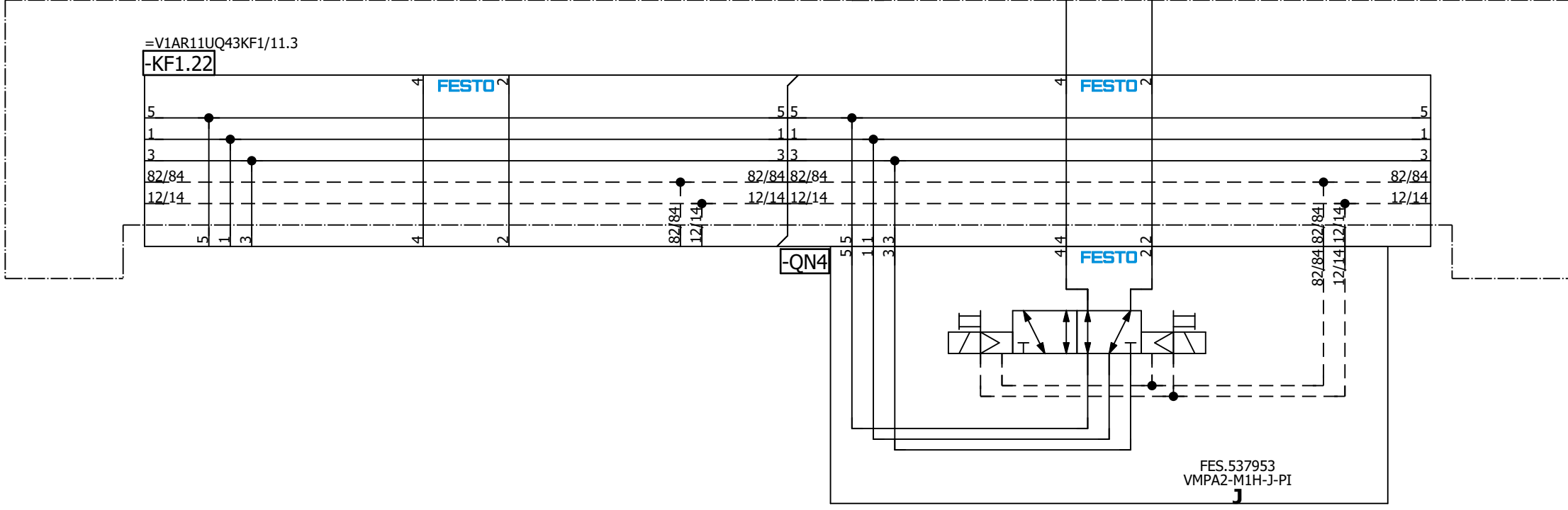

=V1AR11UQ43  
-UQ4-QN4.1  
Clamps 4  
(RST)

=V1AR11UQ43  
-UQ4-QN4.2  
Clamps 4  
(SET)

=V1AR11UQ43UQ5/1

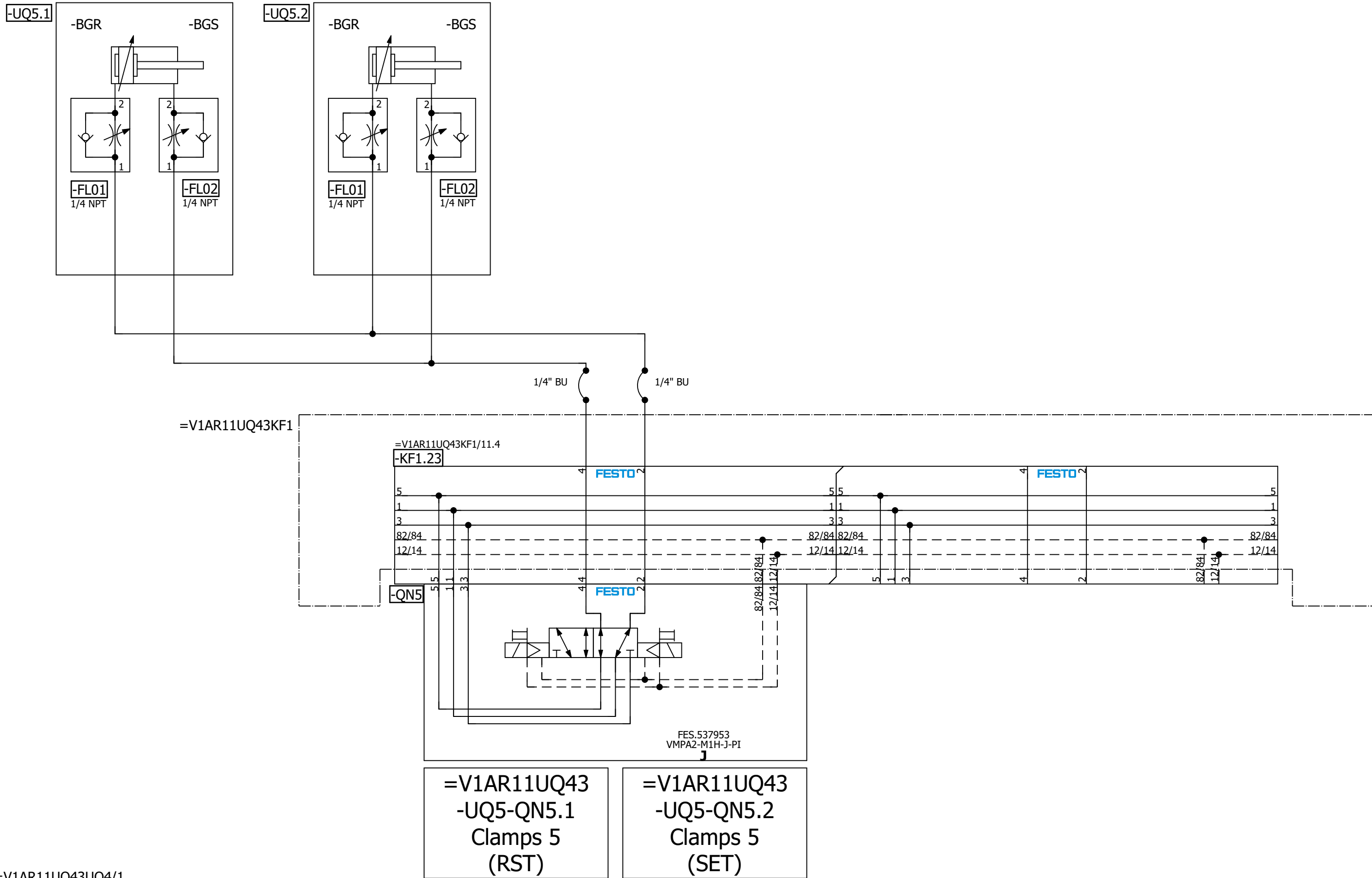

=V1AR11UQ43  
-UQ5-QN5.1  
Clamps 5  
(RST)

=V1AR11UQ43  
-UQ5-QN5.2  
Clamps 5  
(SET)

=V1AR11UQ43UQ4/1

=V1AR11UQ43UQ6/1

		Date	1/4/2023	Volvo Trucks North America		Valiant TMS		Clamps 5		Drawing name: =2V08&MFS-PNEU		= V1AR11UQ43UQ5	
		Ed.	MKLEPADLO	P6700 Side Skin Roof Outer - Cell 2V08		Scale 1:1				Document type: MFS		Project nr: 22-16147	
Modification	Date	Name	Original	Replacement of	Replaced by							Page	1
													112

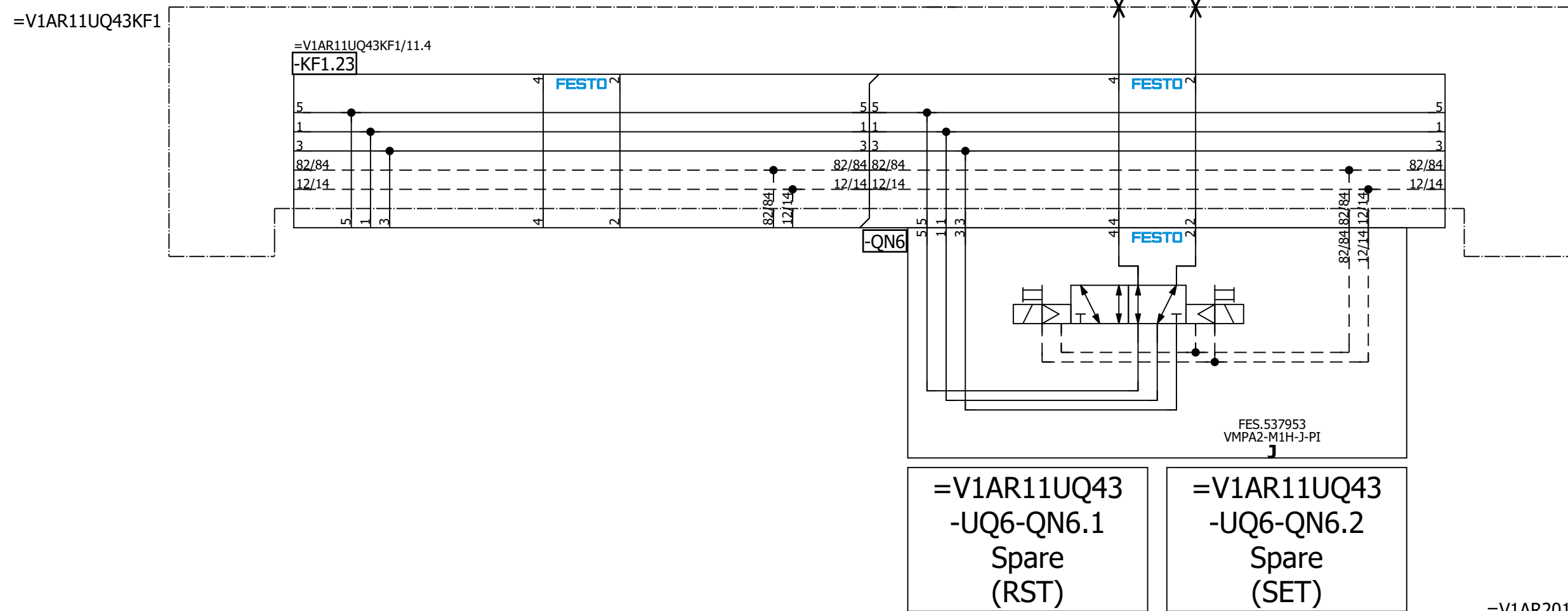

=V1AR11UQ43UQ5/1

=V1AR201UQ41KF1+.AR201UQ41/1

Date		1/4/2023		Volvo Trucks North America		Valiant TMS		Spare		Drawing name:		= V1AR11UQ43UQ6	
Ed.		MKLEPADLO		P6700 Side Skin Roof Outer - Cell 2V08		Scale 1:1				Document type:		= V1AR11UQ43UQ6	
Appr.				Replacement of		Replaced by				Project nr:		Page	
Original										22-16147		1	
Modification		Date		Name		Original				MFS		112	



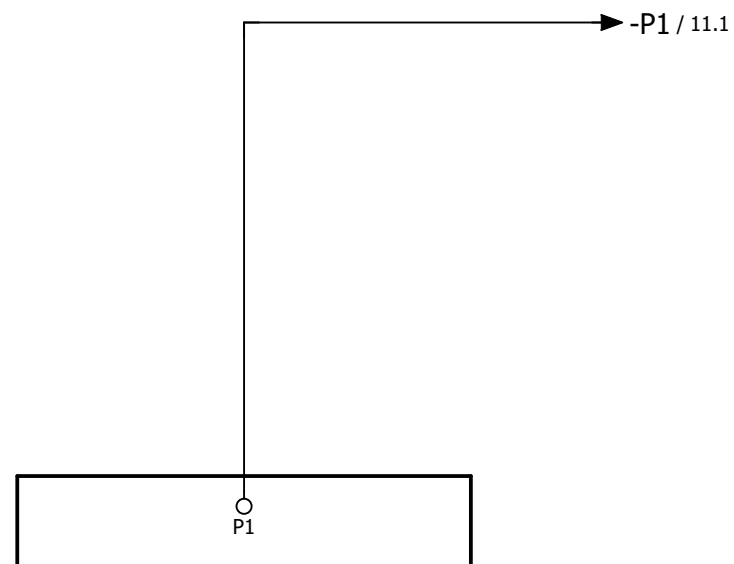

=V1AR11UQ43UQ6+.AR11UQ43/1

		Date	1/4/2023	Volvo Trucks North America			Valiant TMS	AIR SUPPLY GRIPPER	Drawing name:		= V1AR201UQ41KF1
		Ed.	MKLEPADLO	P6700 Side Skin Roof Outer - Cell 2V08					=2V08&MFS-PNEU		+ V1AR201UQ41
		Appr		Replacement of		Replaced by	Scale 1:1		Document type:	Project nr:	Page
Modification	Date	Name	Original						MFS	22-16147	1
											112



M1

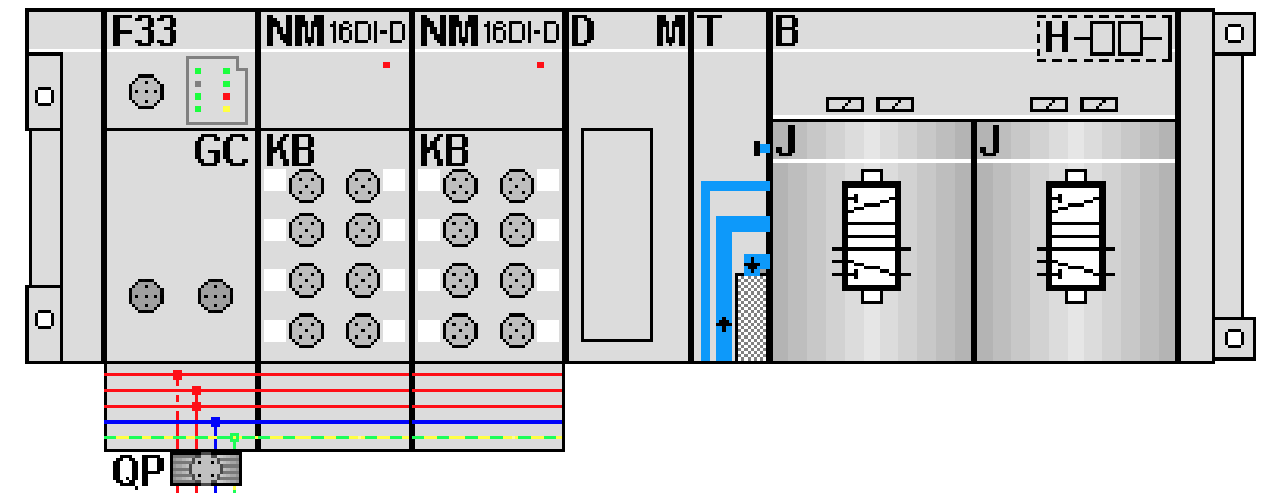

KF1.0

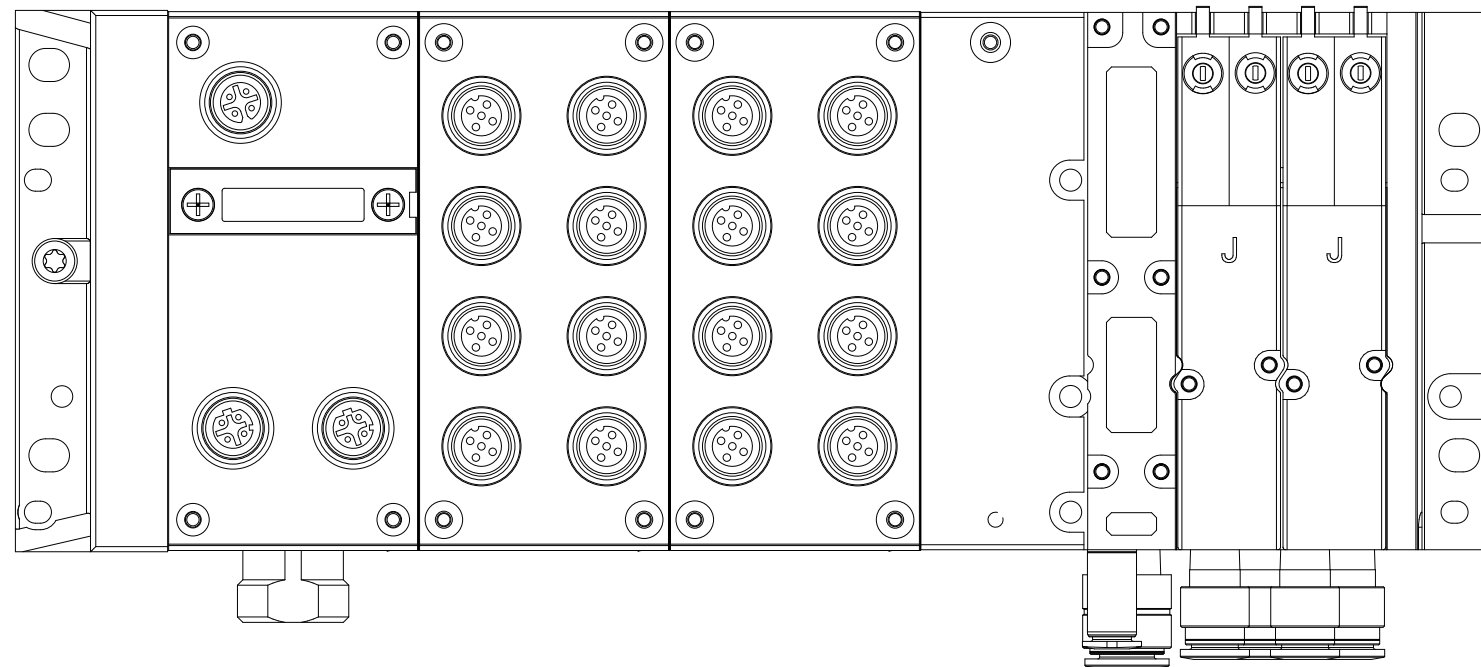

		Date	1/5/2023	Volvo Trucks North America			Valiant TMS	AIR SUPPLY	Drawing name:		= V1AR201UQ41KF1
		Ed.	MKLEPADLO	P6700 Side Skin Roof Outer - Cell 2V08					Document type:		+ V1AR201UQ41
Modification	Date	Name	Original	Replacement of	Replaced by		Scale 1:1		Project nr:	22-16147	Page 5
									MFS		112

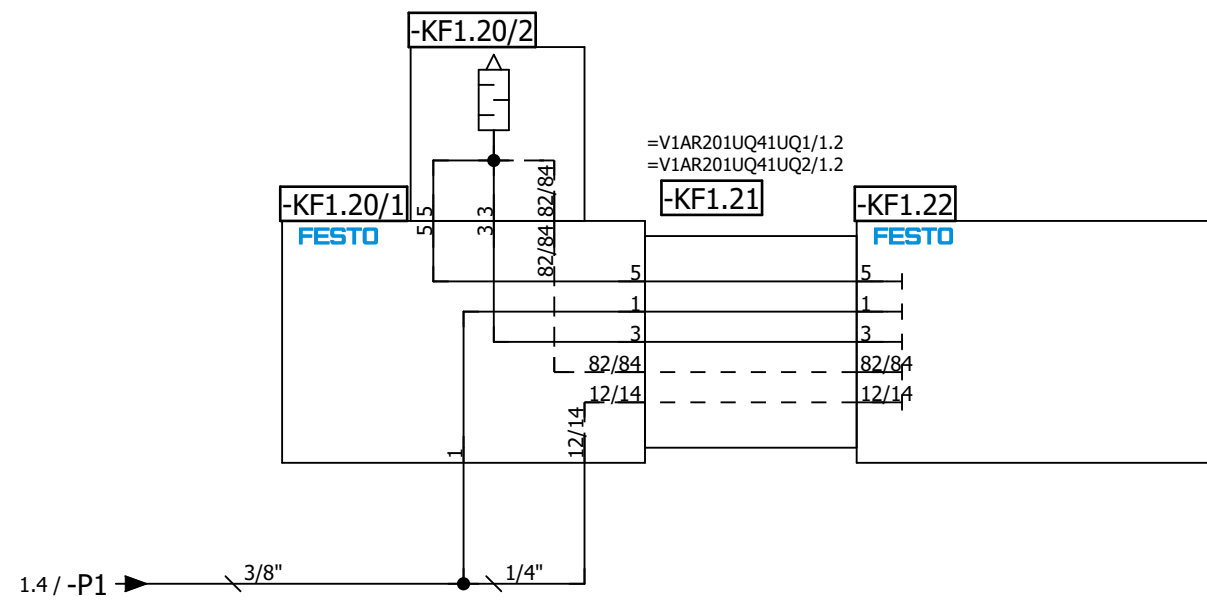
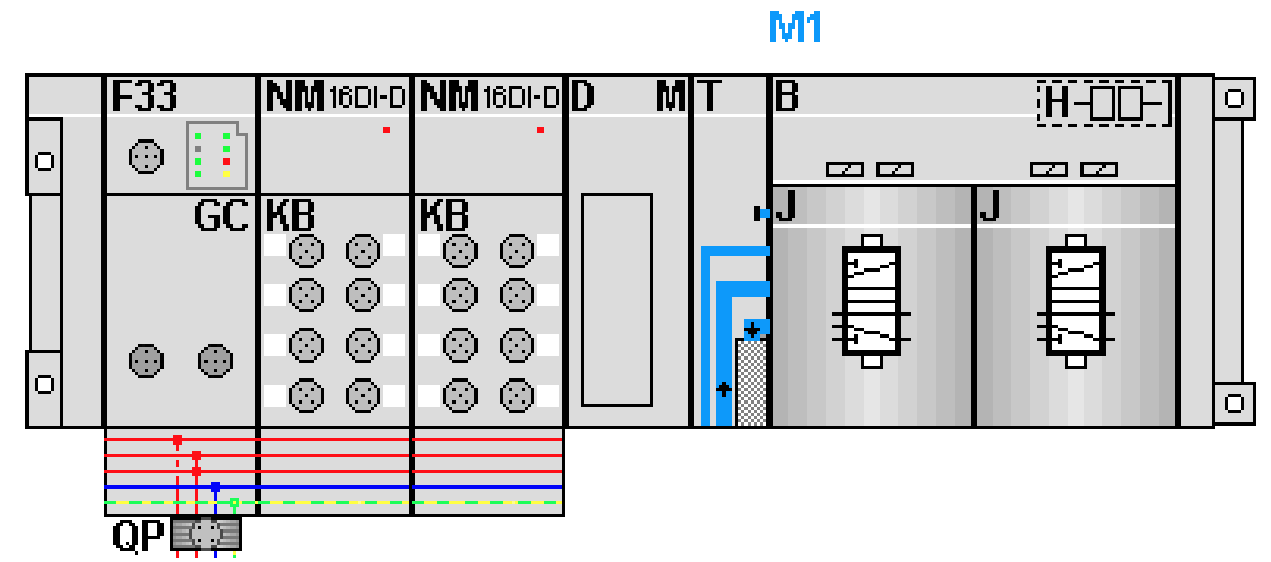

Date		1/4/2023	Volvo Trucks North America		Valiant TMS	AIR SUPPLY	Drawing name:		= V1AR201UQ41KF1
Ed.		MKLEPADLO	P6700 Side Skin Roof Outer - Cell 2V08				=2V08&MFS-PNEU		+ V1AR201UQ41
Appr			Replacement of		Scale 1:1		Document type:	Project nr:	Page
Modification	Date	Name	Original	Replaced by			MFS	22-16147	11
									112



=V1AR201UQ41KF1

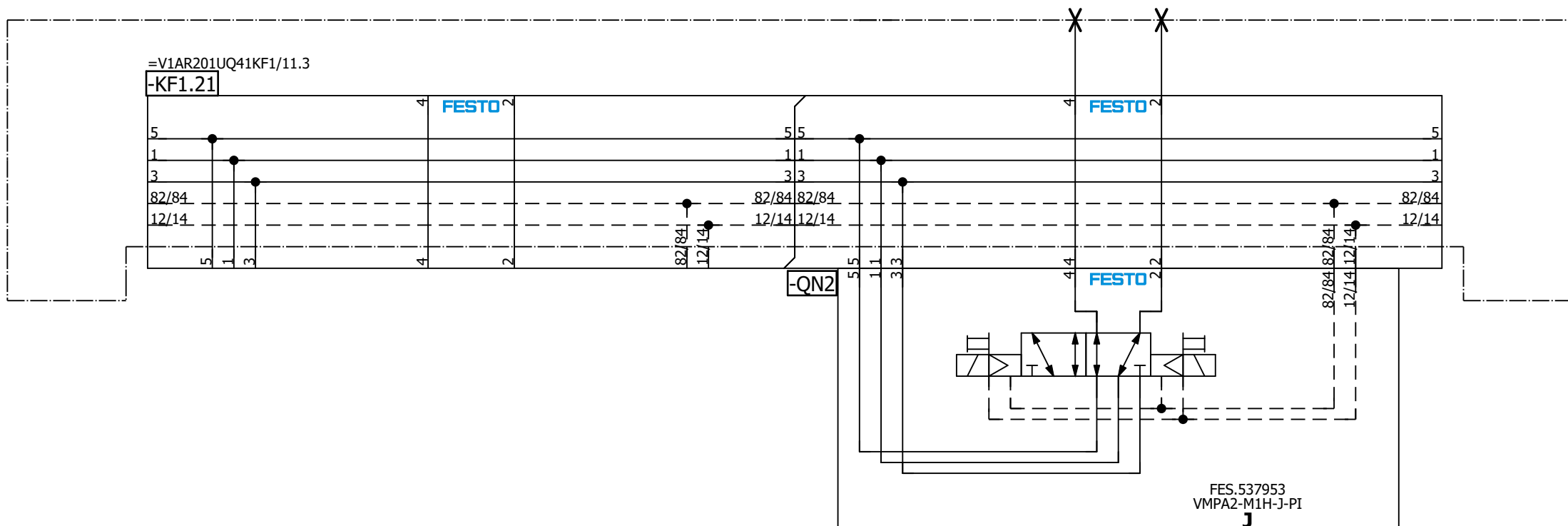

=V1AR201UQ41  
-UQ2-QN2.1  
Spare  
(RST)

=V1AR201UQ41  
-UQ2-QN2.2  
Spare  
(SET)

=V1AR201UQ42KF1+.AR201UQ42/1

=V1AR201UQ41UQ1/1

Date		1/4/2023		Volvo Trucks North America		Valiant TMS		Spare		Drawing name:		= V1AR201UQ41UQ2	
Ed.		MKLEPADLO		P6700 Side Skin Roof Outer - Cell 2V08		Scale 1:1				Document type:		= V1AR201UQ41	
Appr.				Replacement of		Replaced by				Project nr:		Page	
Original										22-16147		1	
Modification		Date		Name		Original				MFS		112	

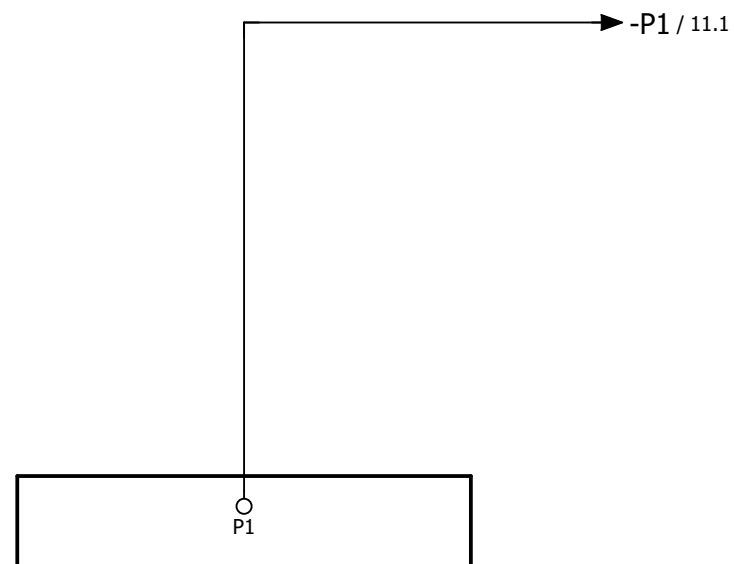

=V1AR201UQ41UQ2+.AR201UQ41/1

		Date	1/4/2023	Volvo Trucks North America			Valiant TMS	AIR SUPPLY GRIPPER	Drawing name: =2V08&MFS-PNEU		= V1AR201UQ42KF1	
		Ed.	MKLEPADLO	P6700 Side Skin Roof Outer - Cell 2V08					Document type: MFS		Project nr: 22-16147	
Modification	Date	Name	Original	Replacement of	Replaced by	Scale 1:1						112

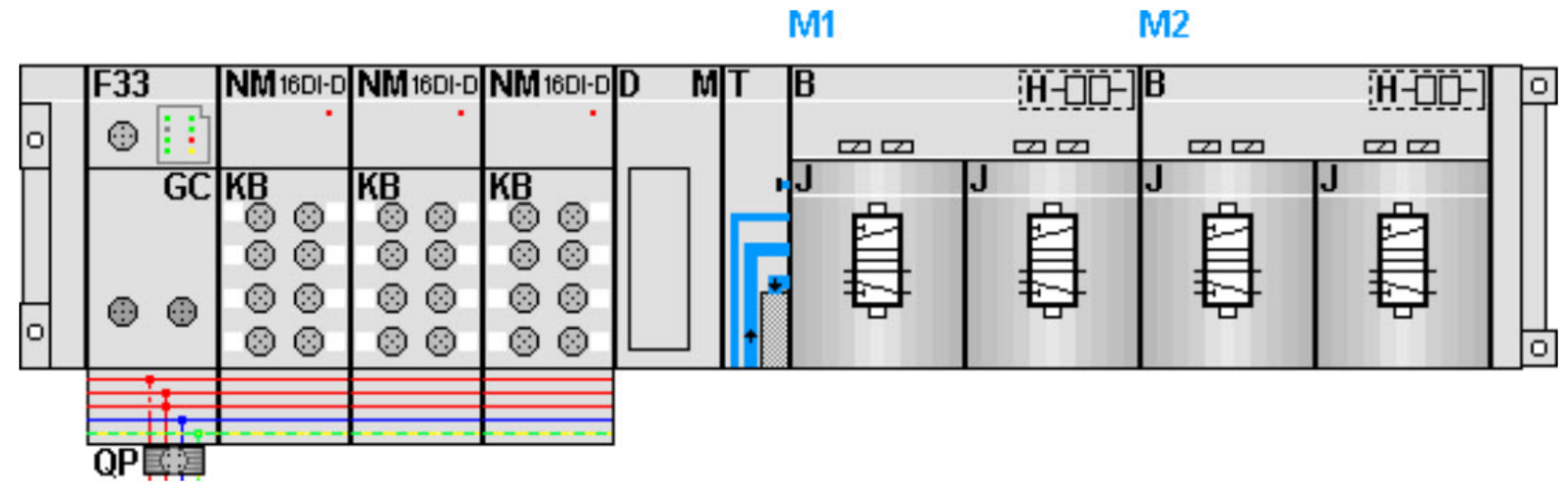

KF1.0

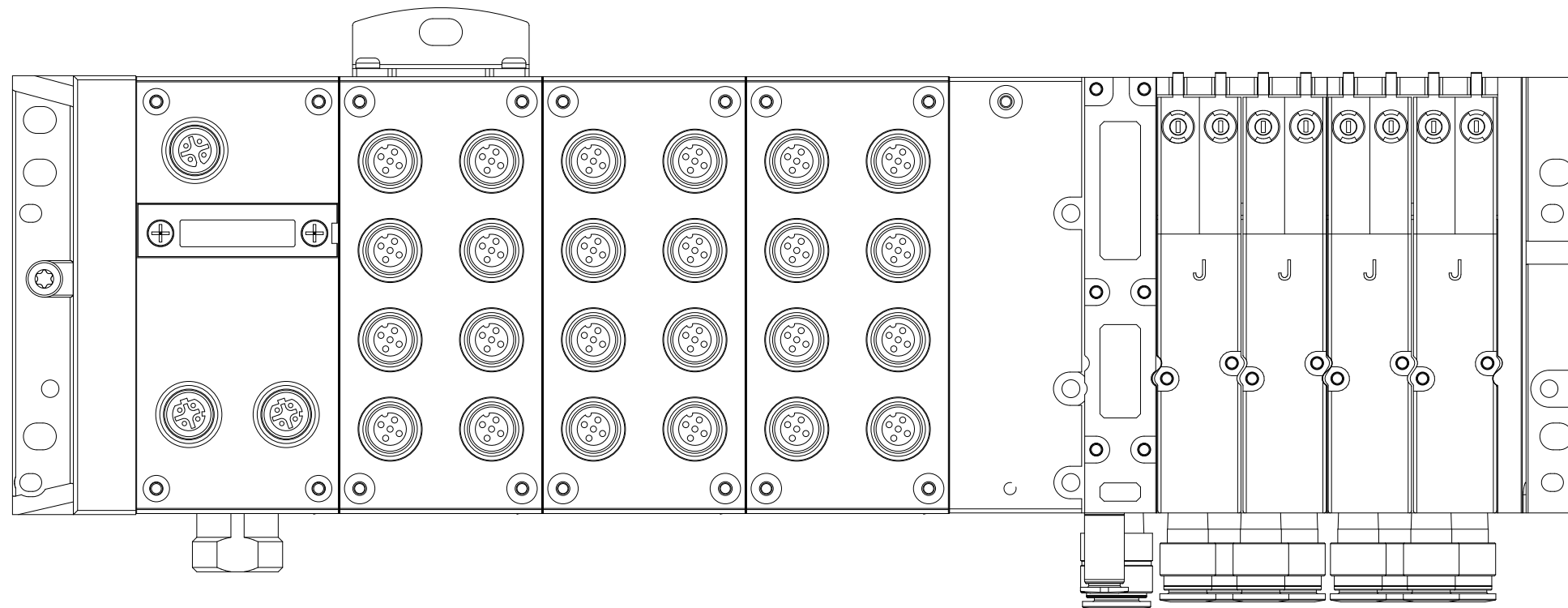

		Date	1/4/2023	Volvo Trucks North America		Valiant TMS		AIR SUPPLY		Drawing name:		= V1AR201UQ42KF1	
		Ed.	MKLEPADLO							= 2V08&MFS-PNEU		+ V1AR201UQ42	
		Appr		P6700 Side Skin Roof Outer - Cell 2V08						Document type:		Project nr:	
Modification	Date	Name	Original	Replacement of	Replaced by	Scale 1:1				MFS		22-16147	
											Page	5	
												112	



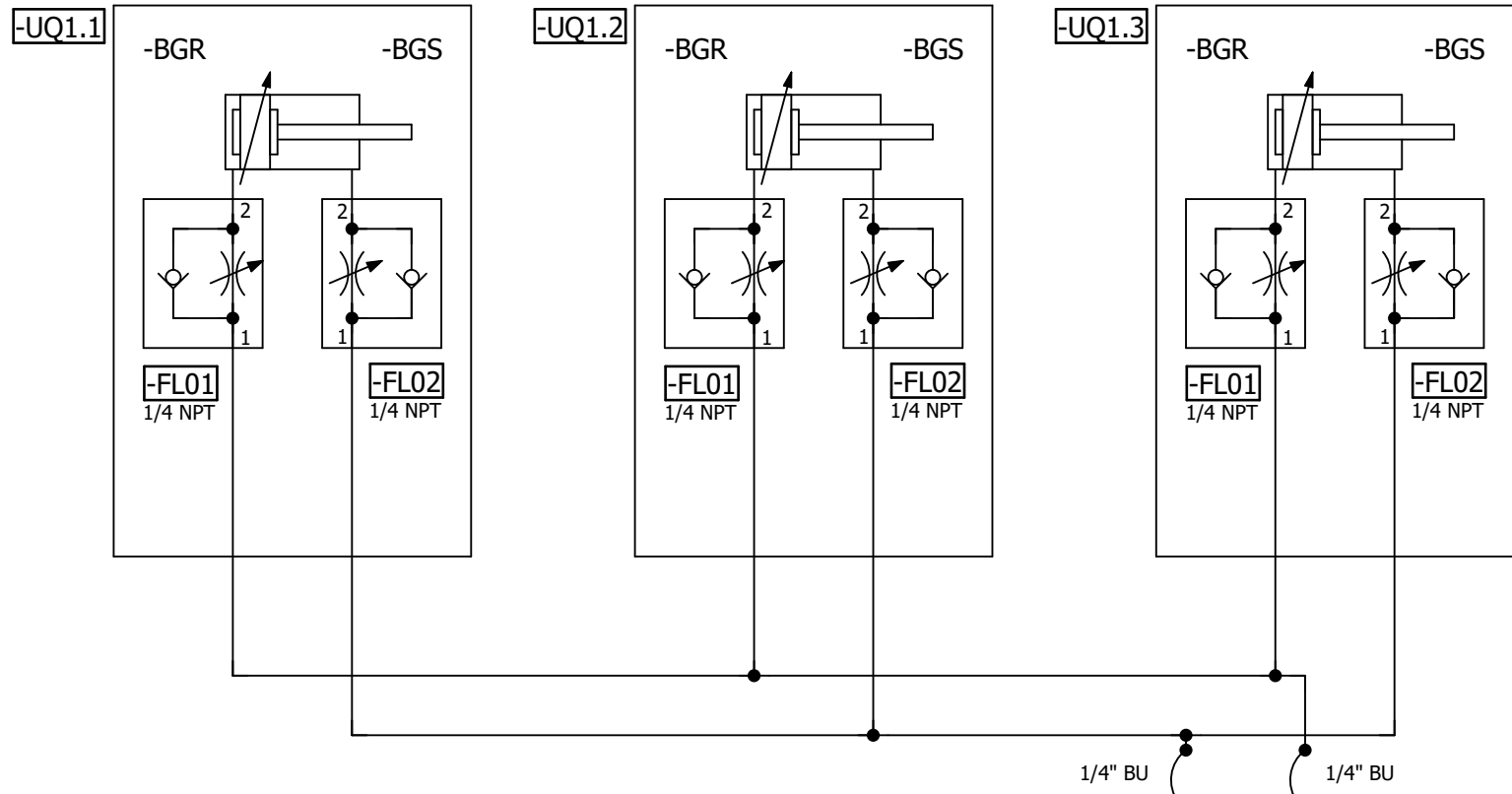

=V1AR201UQ42KF1

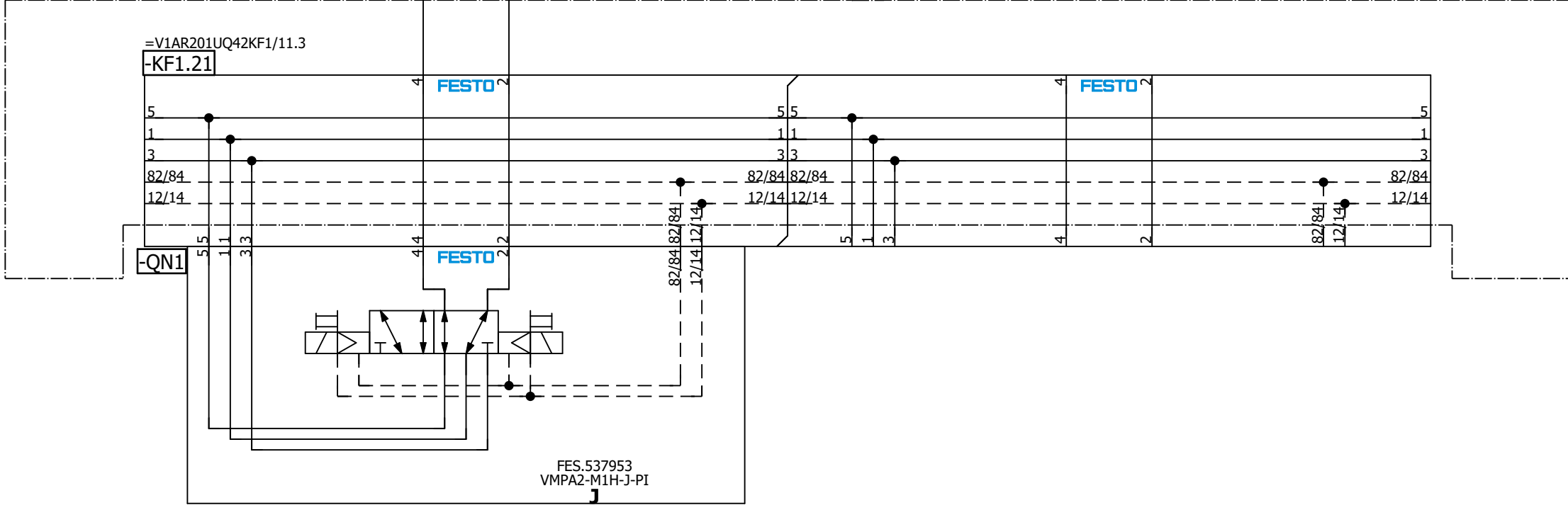

=V1AR201UQ42  
-UQ1-QN1.1  
Clamps 1  
(RST)

=V1AR201UQ42  
-UQ1-QN1.2  
Clamps 1  
(SET)

=V1AR201UQ42KF1/11

=V1AR201UQ42UQ2/1

Date		1/4/2023	Volvo Trucks North America		Valiant TMS		Clamps 1		Drawing name:		= V1AR201UQ42UQ1	
Ed.		MKLEPADLO	P6700 Side Skin Roof Outer - Cell 2V08		Scale 1:1				=2V08&MFS-PNEU		+ V1AR201UQ42	
Appr			Replacement of		Replaced by				Document type:		Project nr:	
Original									MFS		22-16147	
Modification		Date	Name		Original						Page	
											1	
											112	



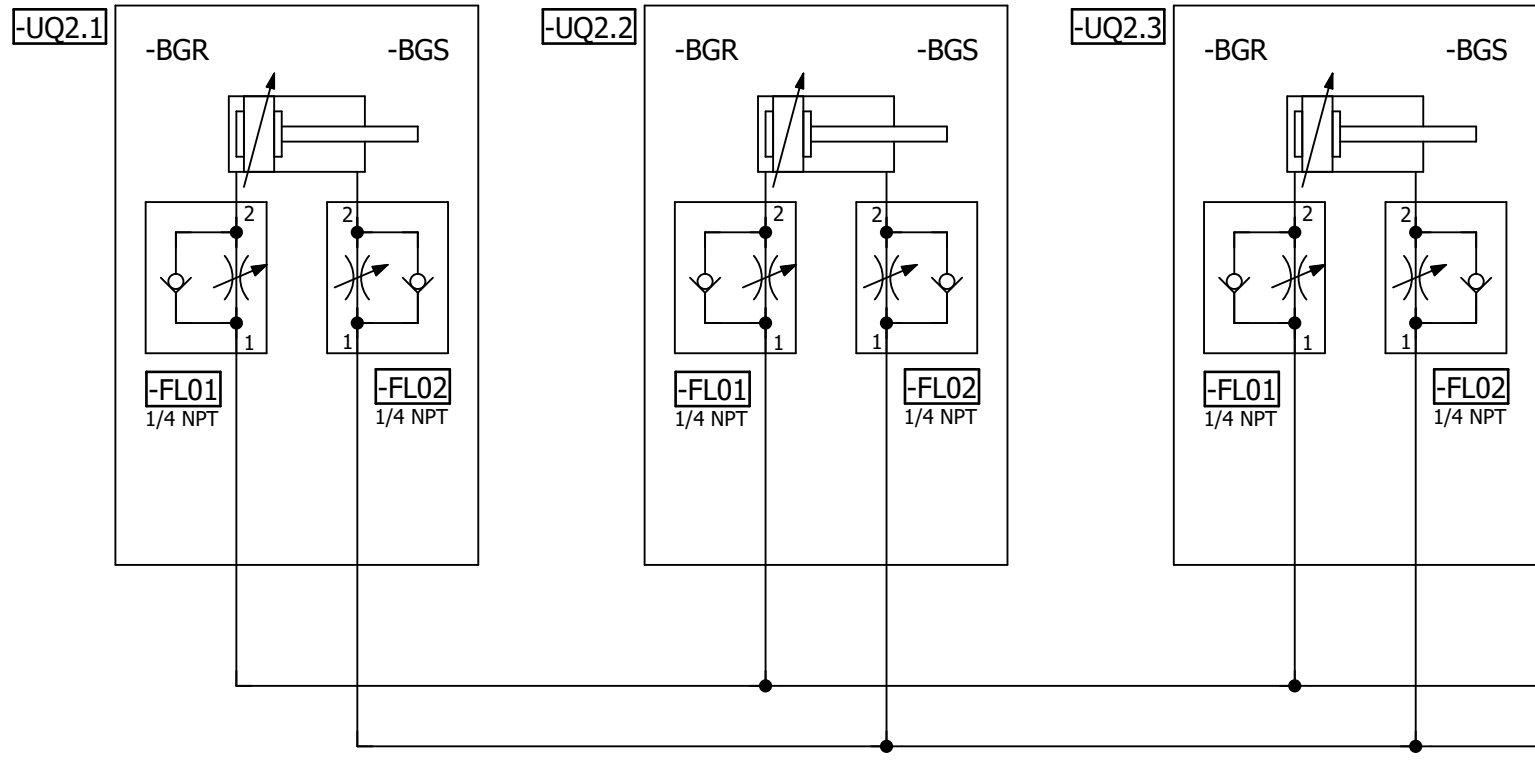

=V1AR201UQ42KF1

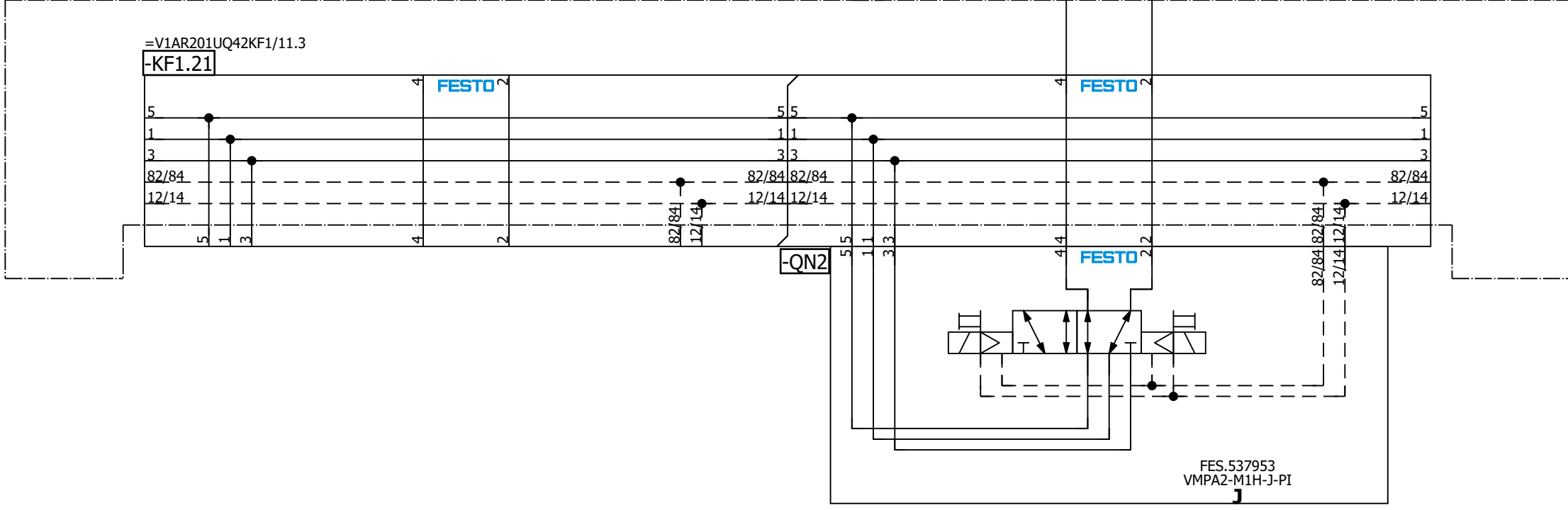

=V1AR201UQ42  
-UQ2-QN2.1  
Clamps 2  
(RST)

=V1AR201UQ42  
-UQ2-QN2.2  
Clamps 2  
(SET)

=V1AR201UQ42UQ3/1

=V1AR201UQ42UQ1/1

Date		1/4/2023		Volvo Trucks North America		Valiant TMS		Clamps 2		Drawing name:		= V1AR201UQ42UQ2	
Ed.		MKLEPADLO		P6700 Side Skin Roof Outer - Cell 2V08		Scale 1:1				Document type:		= V1AR201UQ42	
Appr.				Replacement of		Replaced by				Project nr:		Page	
Original										22-16147		1	
Modification		Date		Name		Original				MFS		112	

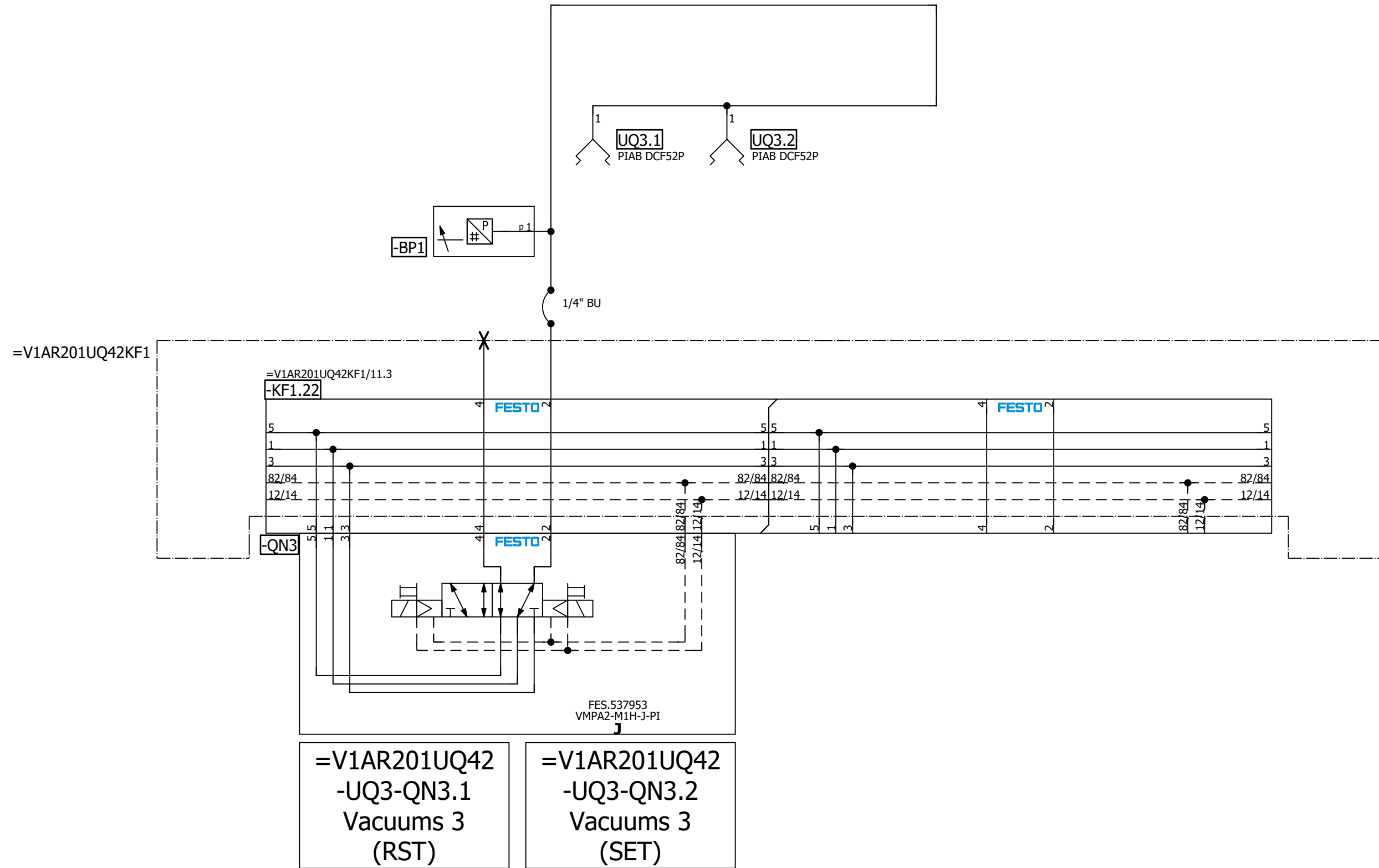

=V1AR201UQ42UQ2/1

=V1AR201UQ42UQ4/1

Date		1/4/2023		Volvo Trucks North America		Valiant TMS		Vacuums 3		Drawing name:		= V1AR201UQ42UQ3	
Ed.		MKLEPADLO		P6700 Side Skin Roof Outer - Cell 2V08		Scale 1:1				Document type:		= 2V08&MFS-PNEU	
Appr				Replacement of		Replaced by				Project nr:		+ V1AR201UQ42	
Modification		Date		Name		Original				MFS		Page 1	
										22-16147		112	

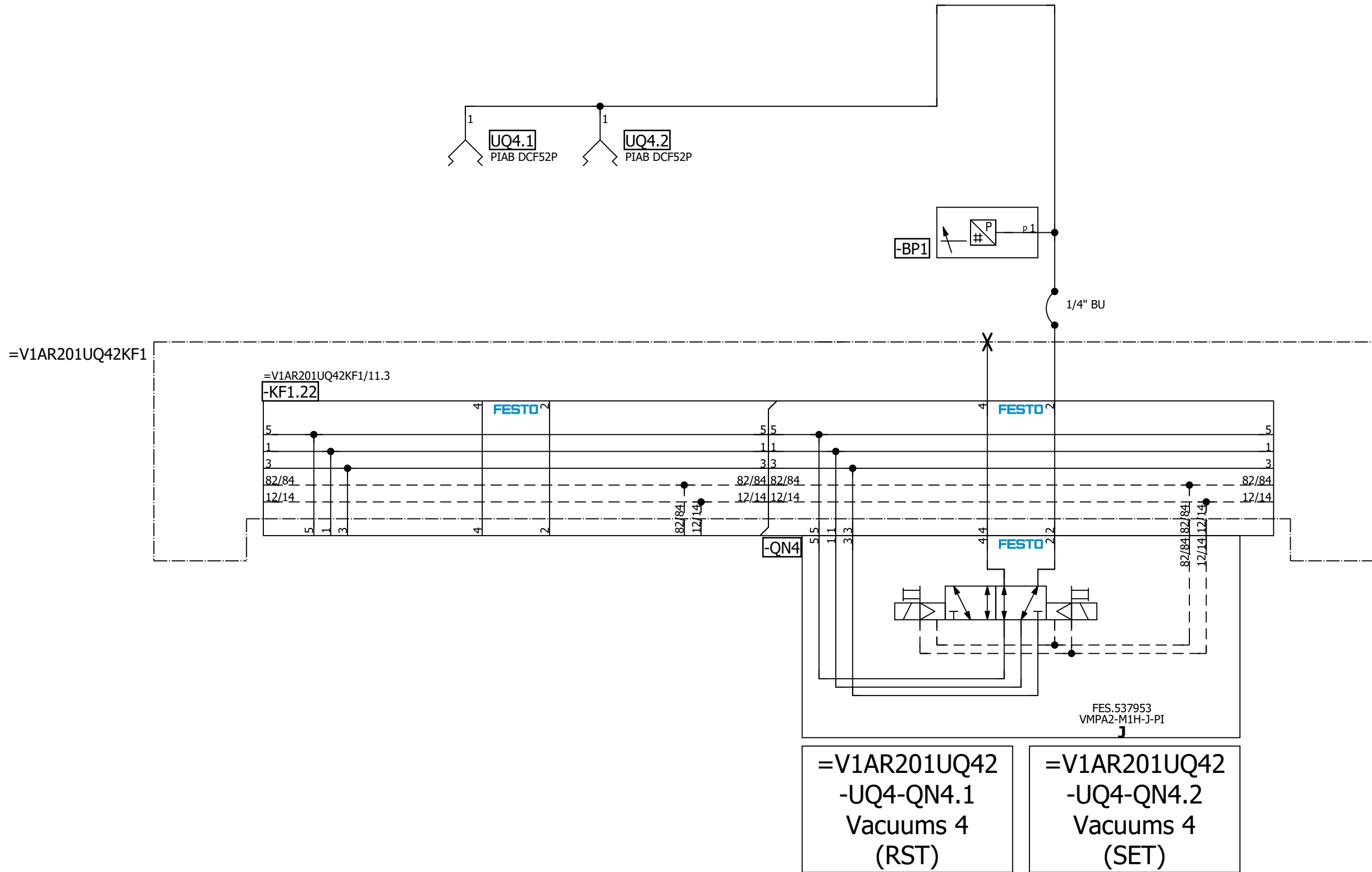

=V1AR201UQ42UQ3/1

=V1GM1+KH1/1

Date		1/4/2023		Volvo Trucks North America		Valiant TMS		Vacuums 4		Drawing name:		= V1AR201UQ42UQ4	
Ed.		MKLEPADLO		P6700 Side Skin Roof Outer - Cell 2V08		Scale 1:1				Document type:		+ V1AR201UQ42	
Appr.				Replacement of		Replaced by				Project nr:		Page 1	
Modification		Date		Name		Original				22-16147		112	

A2

=KH0+KH0/1.7 / +V1GM1KH1-P1

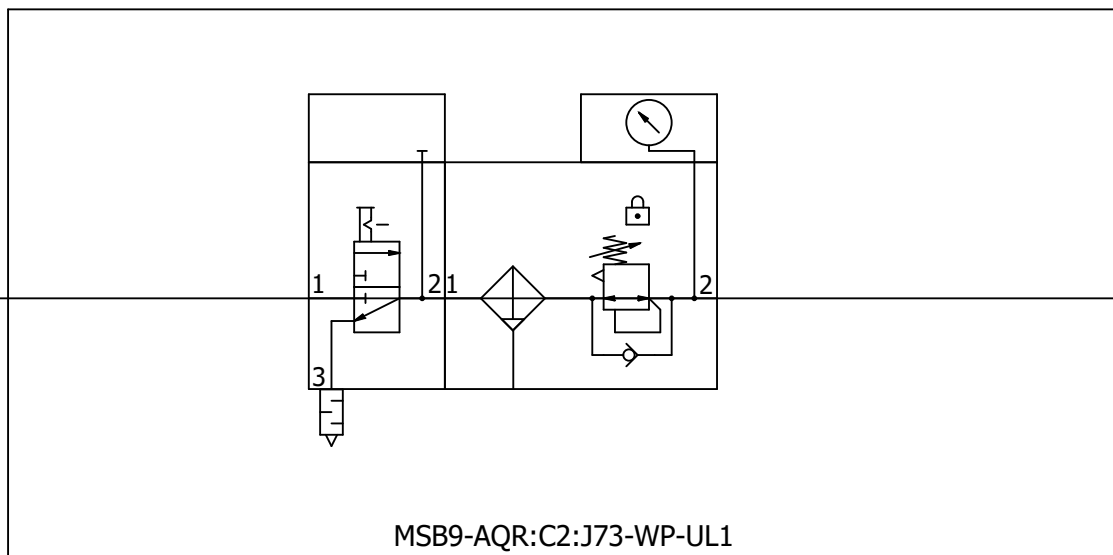

MSB9-AQR:C2:J73-WP-UL1

1/2"

+V1GM1KH1-P1 /  
Lift Assist

=V1AR201UQ42UQ4+V1AR201UQ42/1

=V1GM2/1

Modification	Date	Name	Date	1/4/2023	Volvo Trucks North America	Valiant TMS	Incoming air supply (Lift Assist)	Drawing name:		= V1GM1
			Ed.	MKLEPADLO				=2V08&MFS-PNEU		+ KH1
			Appr.		P6700 Side Skin Roof Outer - Cell 2V08	Scale 1:1	Document type:	Project nr:	Page	1
			Original				Replacement of	Replaced by	MFS	22-16147



A2

=KH0+KH0/1.7 / +V1GM2KH1-P1

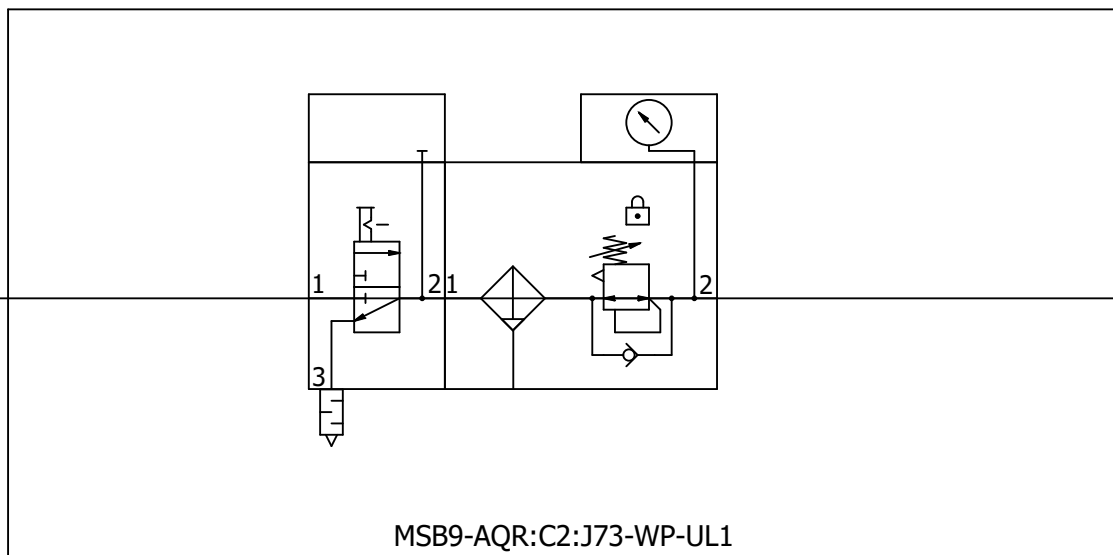

MSB9-AQR:C2:J73-WP-UL1

1/2"

+V1GM2KH1-P1 /  
Lift Assist

=V1GM1/1

=V1PF1/1

		Date	1/4/2023	Volvo Trucks North America			Valiant TMS	Incoming air supply (Lift Assist)	Drawing name:		= V1GM2
		Ed.	MKLEPADLO	P6700 Side Skin Roof Outer - Cell 2V08						=2V08&MFS-PNEU	
		Appr		Replacement of		Replaced by	Scale 1:1	Document type:		Project nr:	Page
Modification	Date	Name	Original					MFS		22-16147	1
											112

A2

=KH0+KH0/1.7 / +V1PF1KH1-P1

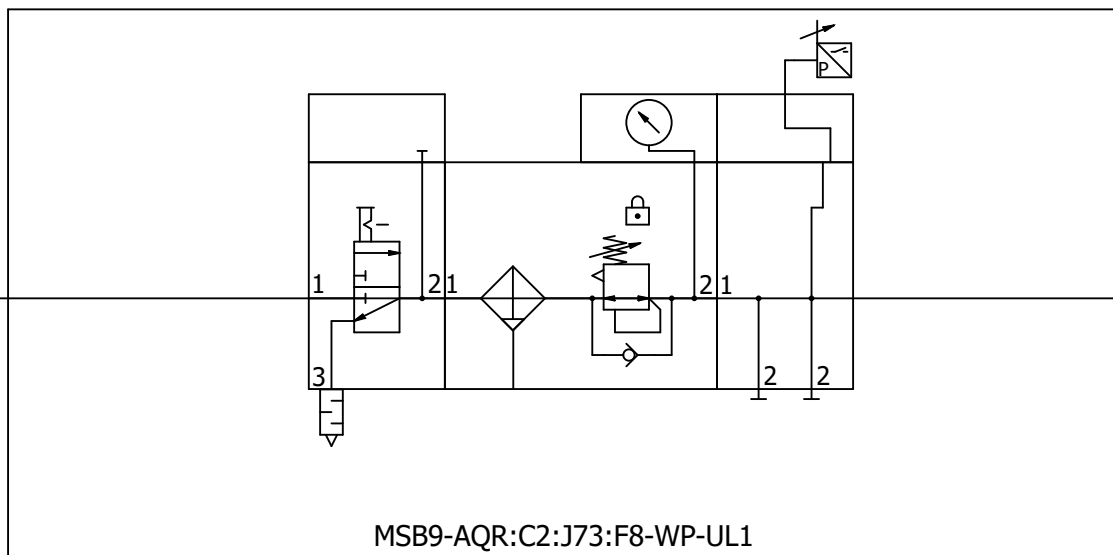

MSB9-AQR:C2:J73:F8-WP-UL1

1/2"

+V1PF1-P1 / =V1PF1KF1+V1PF1/11.1

=V1GM2/1

=V1PF1KF1+V1PF1/5

		Date	1/4/2023	Volvo Trucks North America			Valiant TMS	Incoming air supply (Fixture)	Drawing name:		= V1PF1
		Ed.	MKLEPADLO	P6700 Side Skin Roof Outer - Cell 2V08						=2V08&MFS-PNEU	
		Appr		Replacement of			Scale 1:1	Document type:		Project nr:	Page
Modification	Date	Name	Original	Replaced by				MFS		22-16147	1
											112

M1

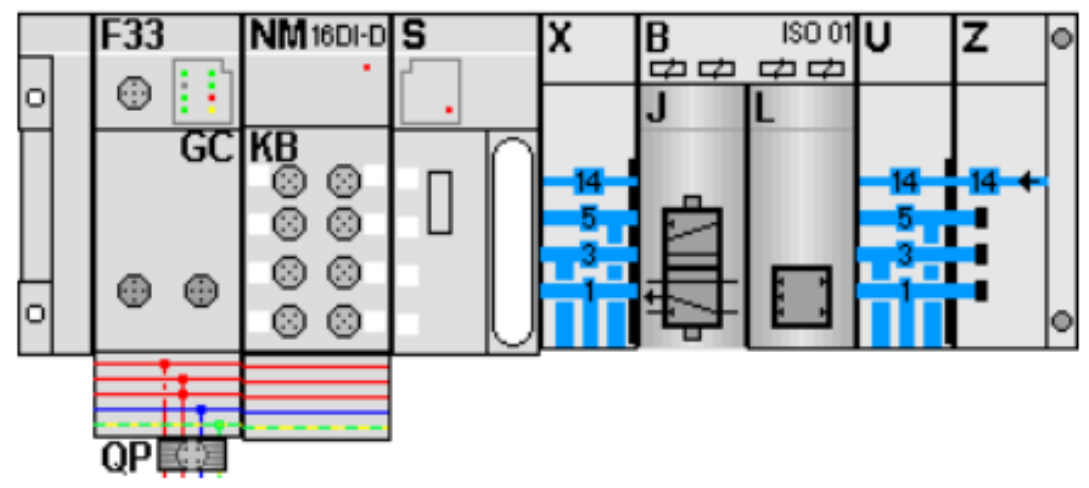

KF1.0

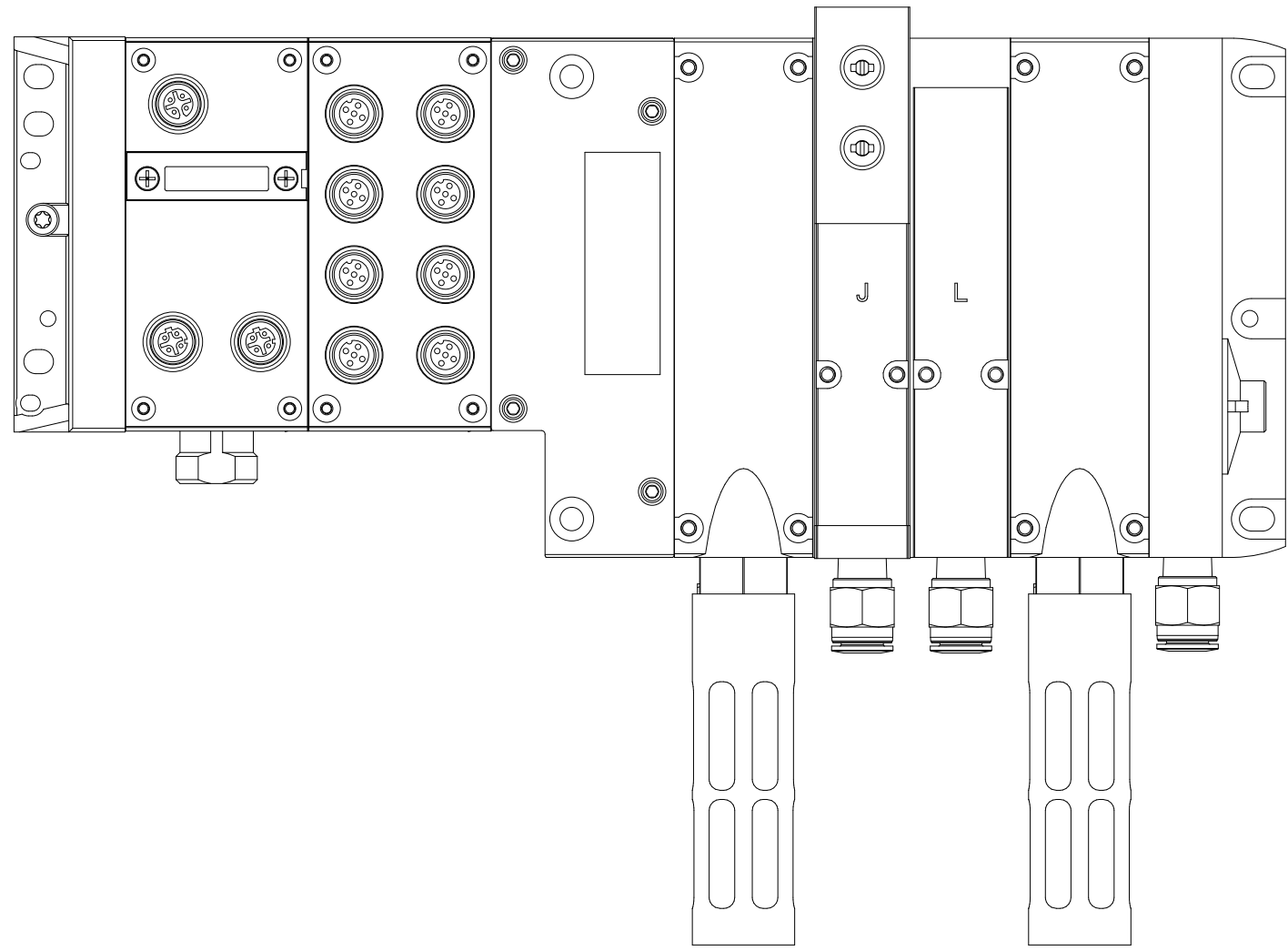

=V1PF1+KH1/1

11

Modification		Date	Name	Original	Replacement of	Replaced by	Scale 1:1	Drawing name: =2V08&MFS-PNEU Document type: MFS		Project nr: 22-16147		Page 5
				Date: 1/4/2023 Ed.: MKLEPADLO Appr.:	Volvo Trucks North America P6700 Side Skin Roof Outer - Cell 2V08		Valiant TMS Scale 1:1	AIR SUPPLY CONFIGURATION		= V1PF1KF1 + V1PF1		112

M1

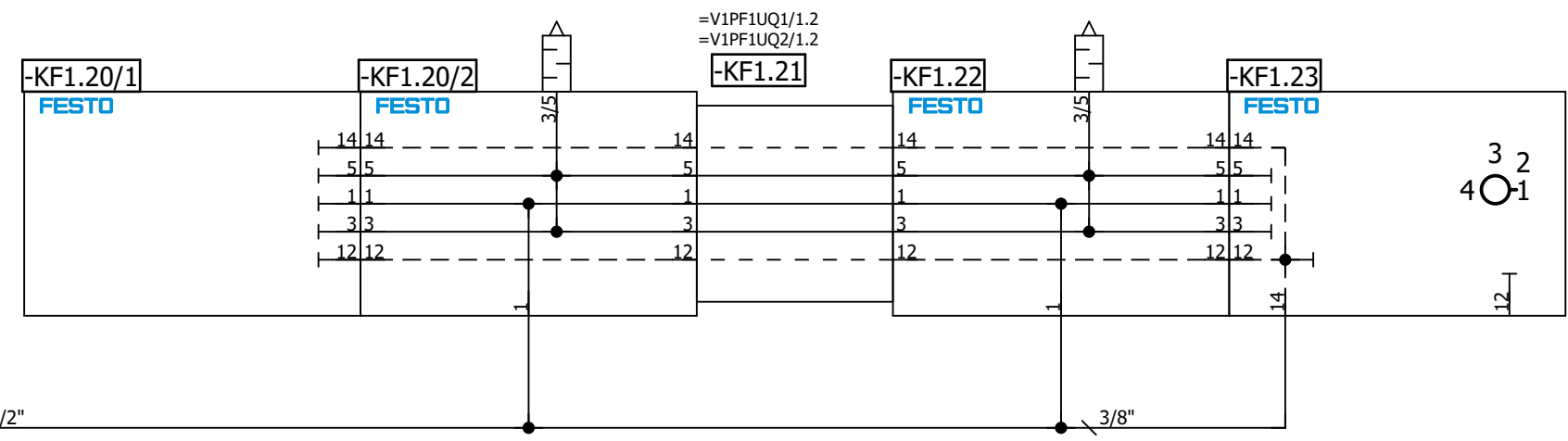
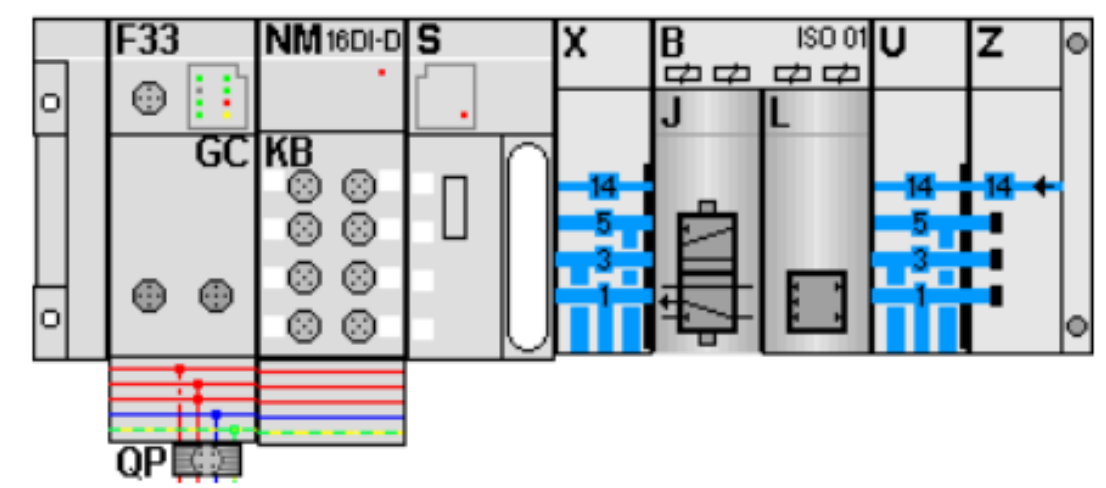

=V1PF1+KH1/1.6 / -P1

=V1PF1UQ1/1

5

Date		1/4/2023	Volvo Trucks North America		Valiant TMS	AIR SUPPLY	Drawing name:		= V1PF1KF1
Ed.		MKLEPADLO	P6700 Side Skin Roof Outer - Cell 2V08				=2V08&MFS-PNEU		+ V1PF1
Appr			Replacement of		Scale 1:1	Document type:	Project nr:	Page	11
Original			Replaced by						MFS



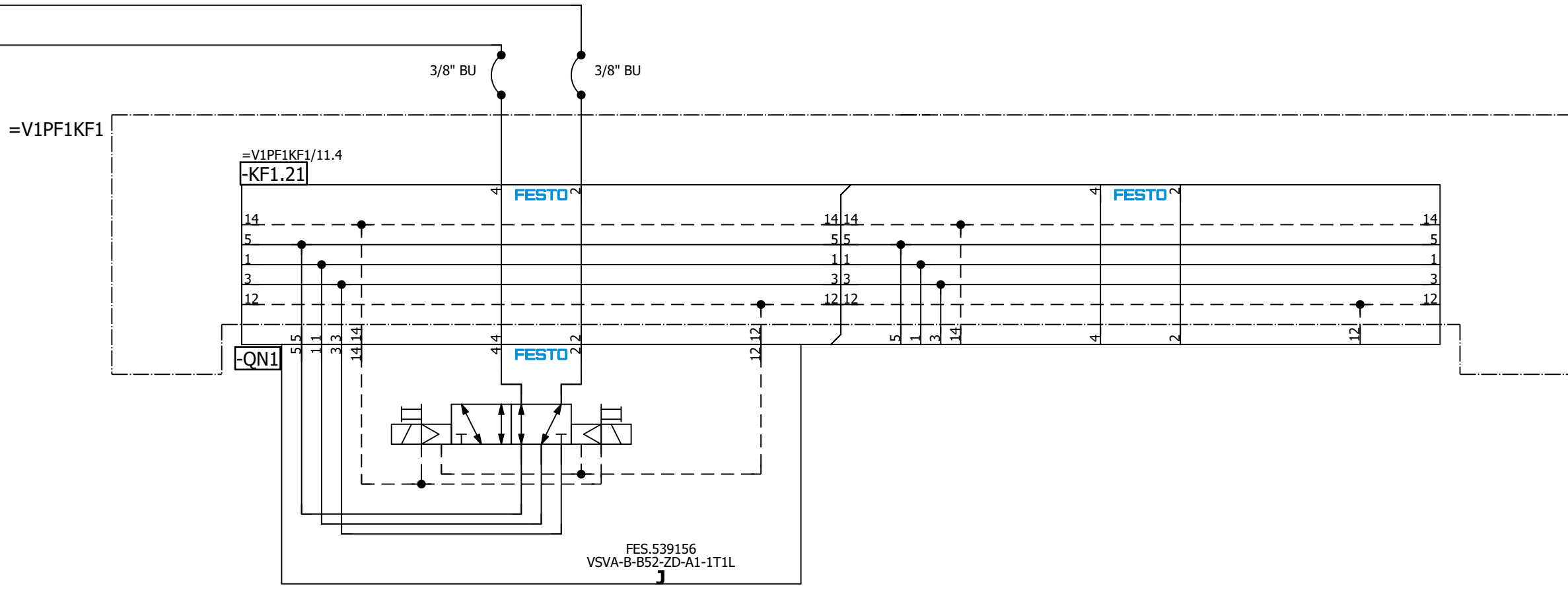
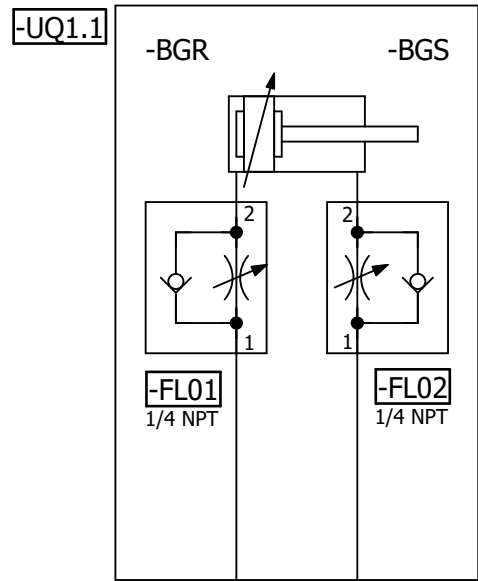

=V1PF1  
-UQ1-QN1.1  
Clamp  
(RST)

=V1PF1  
-UQ1-QN1.2  
Clamp  
(SET)

=V1PF1KF1/11

=V1PF1UQ2/1

Date		1/4/2023	Volvo Trucks North America		Valiant TMS	Clamp	Drawing name:		= V1PF1UQ1
Ed.		MKLEPADLO	P6700 Side Skin Roof Outer - Cell 2V08				=2V08&MFS-PNEU		+ V1PF1
Appr			Replacement of		Scale 1:1		Document type:		MFS
Original			Replaced by				Project nr:		22-16147
Modification	Date	Name	Original				Page		1
									112









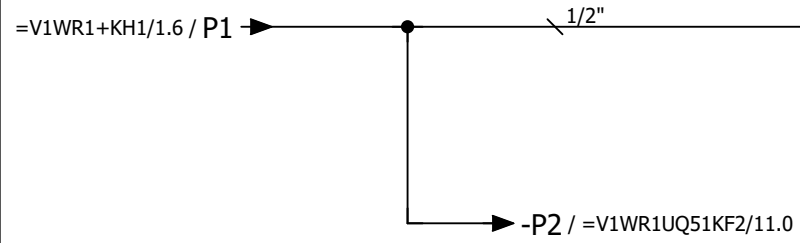
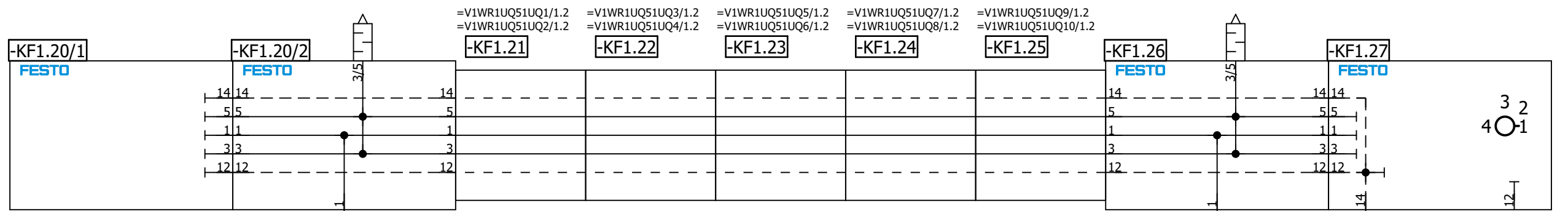
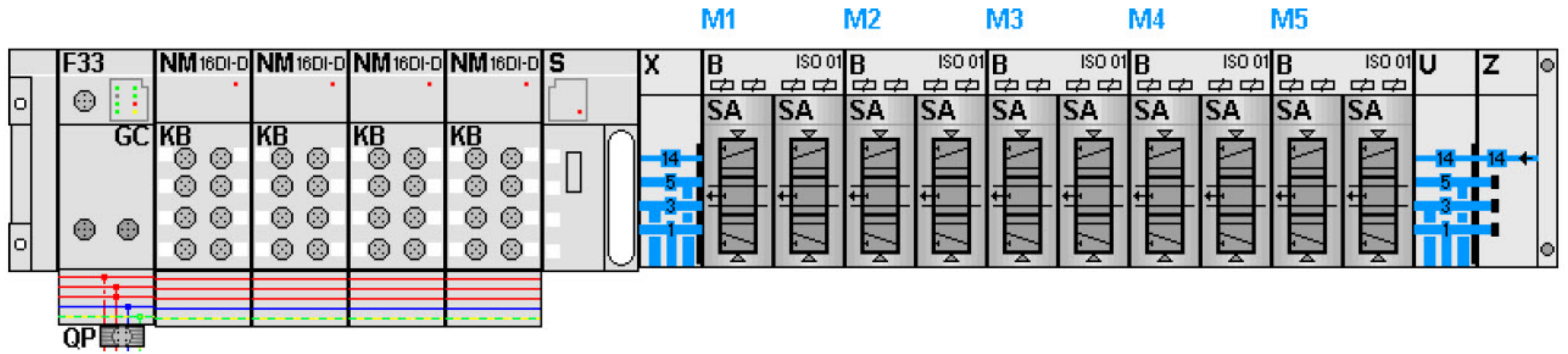

Date		1/4/2023	Volvo Trucks North America		Valiant TMS	AIR SUPPLY	Drawing name:		= V1WR1UQ51KF1
Ed.		MKLEPADLO	P6700 Side Skin Roof Outer - Cell 2V08				=2V08&MFS-PNEU		+ V1WR1UQ51
Appr			Replacement of		Scale 1:1	Document type:		MFS	Project nr:
Original			Replaced by			22-16147		Page	11
								112	

M1

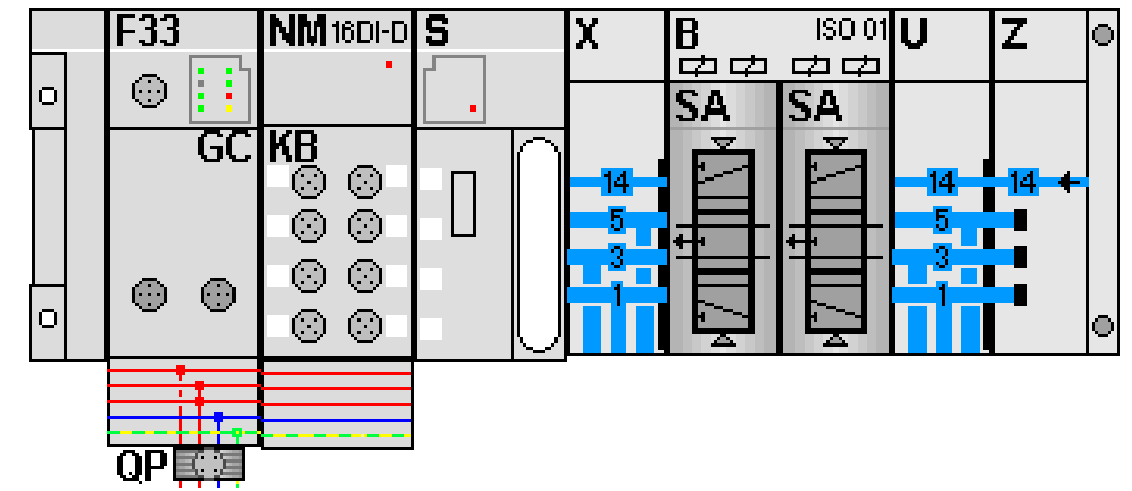

KF2.0

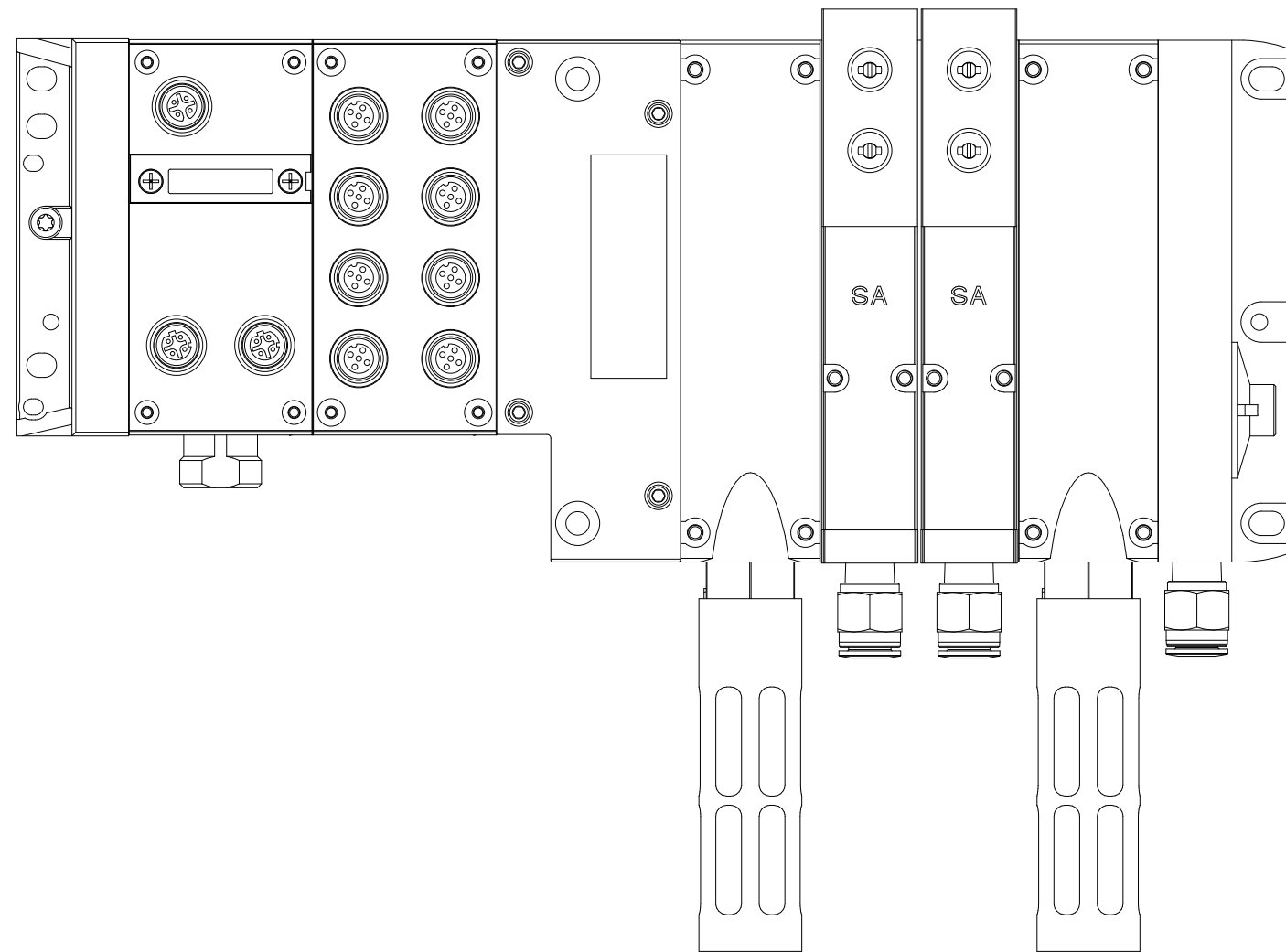

=V1WR1UQ51KF1/11

11

		Date	1/4/2023	Volvo Trucks North America		Valiant TMS	AIR SUPPLY CONFIGURATION	Drawing name:		= V1WR1UQ51KF2	
		Ed.	MKLEPADLO					=2V08&MFS-PNEU			
		Appr		P6700 Side Skin Roof Outer - Cell 2V08		Scale 1:1	Document type:		Project nr:		Page
Modification	Date	Name	Original	Replacement of	Replaced by		MFS		22-16147		5
											112



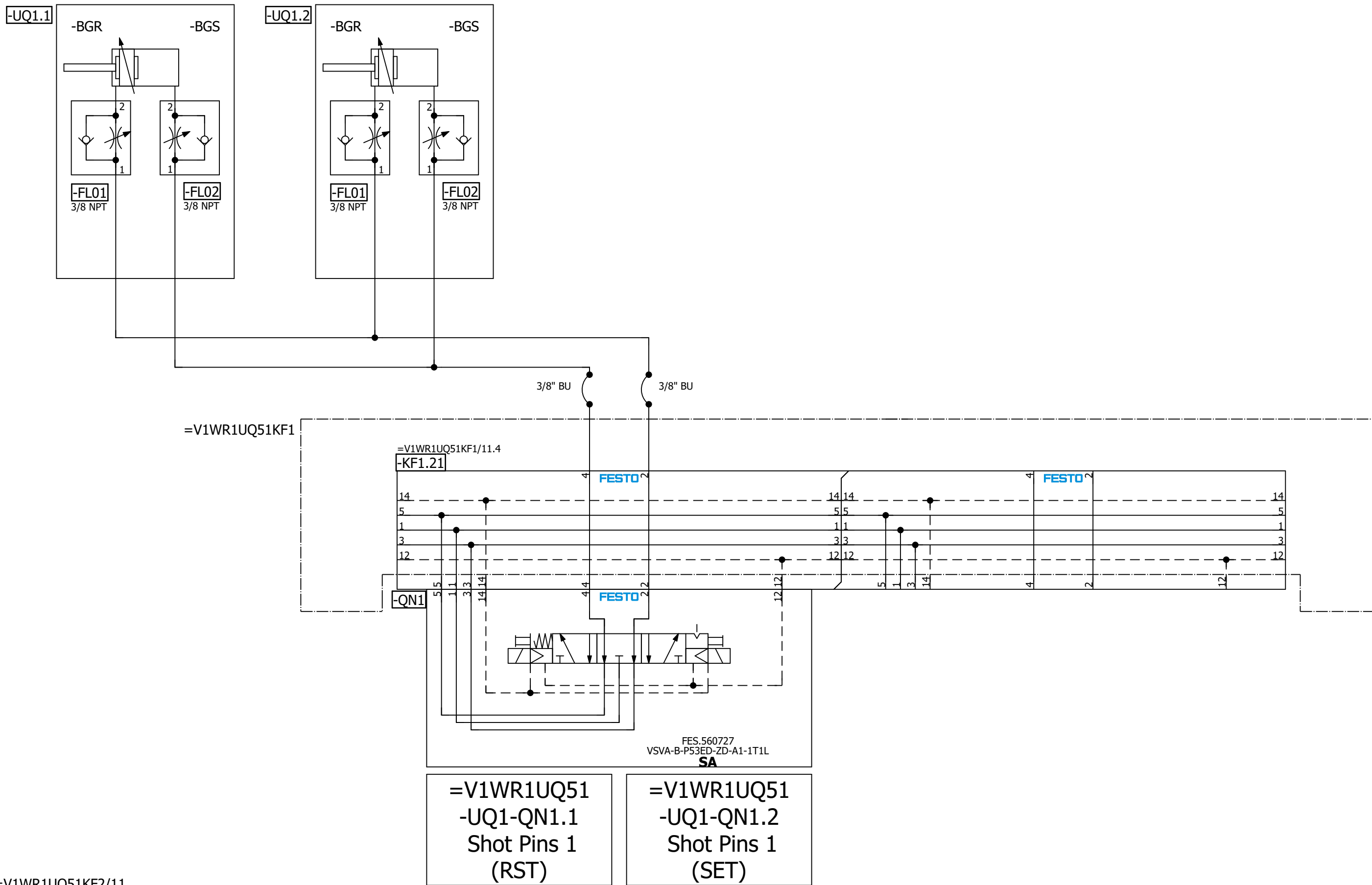

=V1WR1UQ51KF2/11

=V1WR1UQ51UQ2/1

Date		1/11/2023	Volvo Trucks North America		Valiant TMS		Shot Pins 1		Drawing name:		= V1WR1UQ51UQ1	
Ed.		MKLEPADLO	P6700 Side Skin Roof Outer - Cell 2V08		Scale 1:1				Document type:		= 2V08&MFS-PNEU	
Appr.			Replacement of		Replaced by				Project nr:		+ V1WR1UQ51	
Modification	Date	Name	Original						MFS		Page 1	
									22-16147		112	



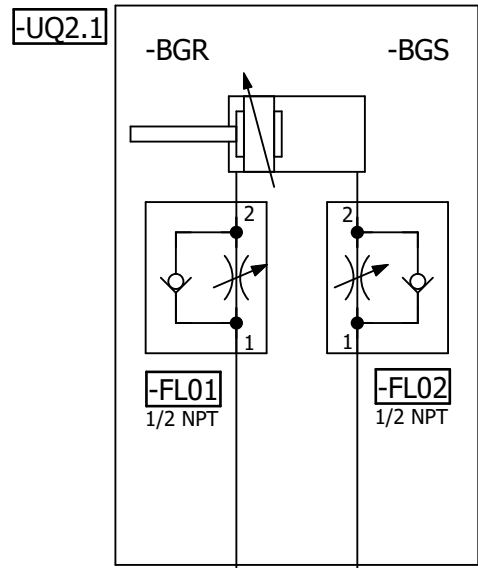

=V1WR1UQ51KF1

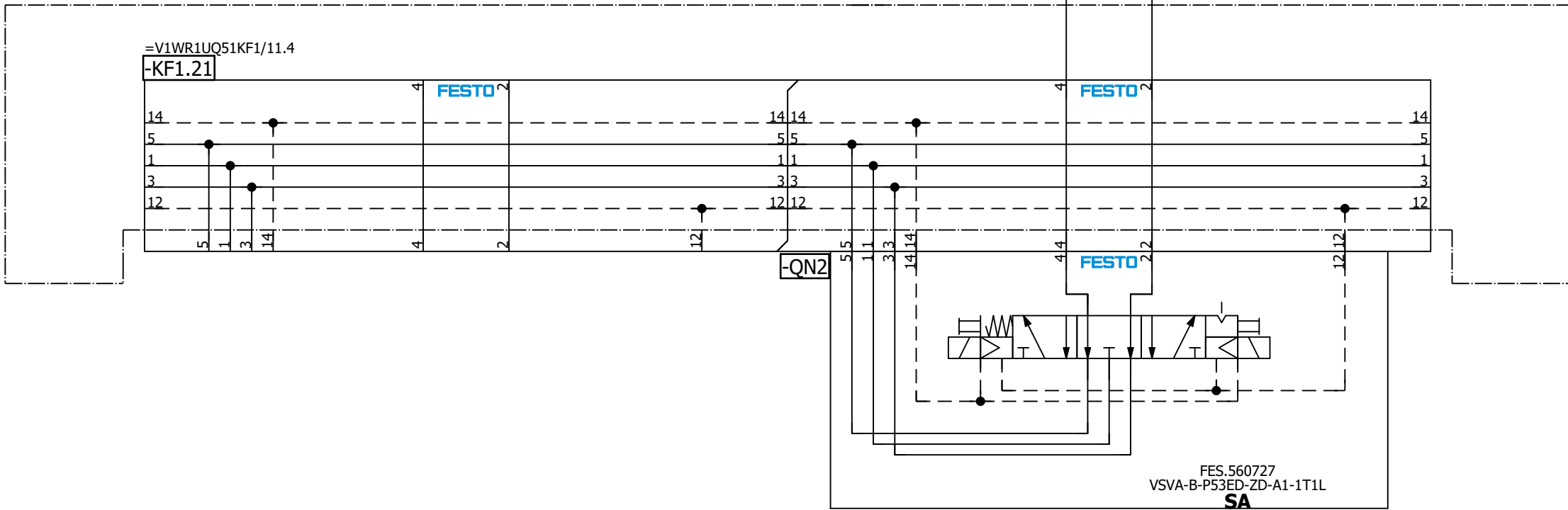

=V1WR1UQ51  
-UQ2-QN2.1  
Cyl Slide 2  
(RST)

=V1WR1UQ51  
-UQ2-QN2.2  
Cyl Slide 2  
(SET)

=V1WR1UQ51UQ3/1

=V1WR1UQ51UQ1/1			Date	1/11/2023	Volvo Trucks North America	Valiant TMS	Cyl Slide 2	Drawing name:	= V1WR1UQ51UQ2		
			Ed.	MKLEPADLO		Scale 1:1	=2V08&MFS-PNEU		+ V1WR1UQ51		
			Appr				Document type:	MFS	Project nr:	22-16147	Page
Modification	Date	Name	Original		Replacement of	Replaced by					112

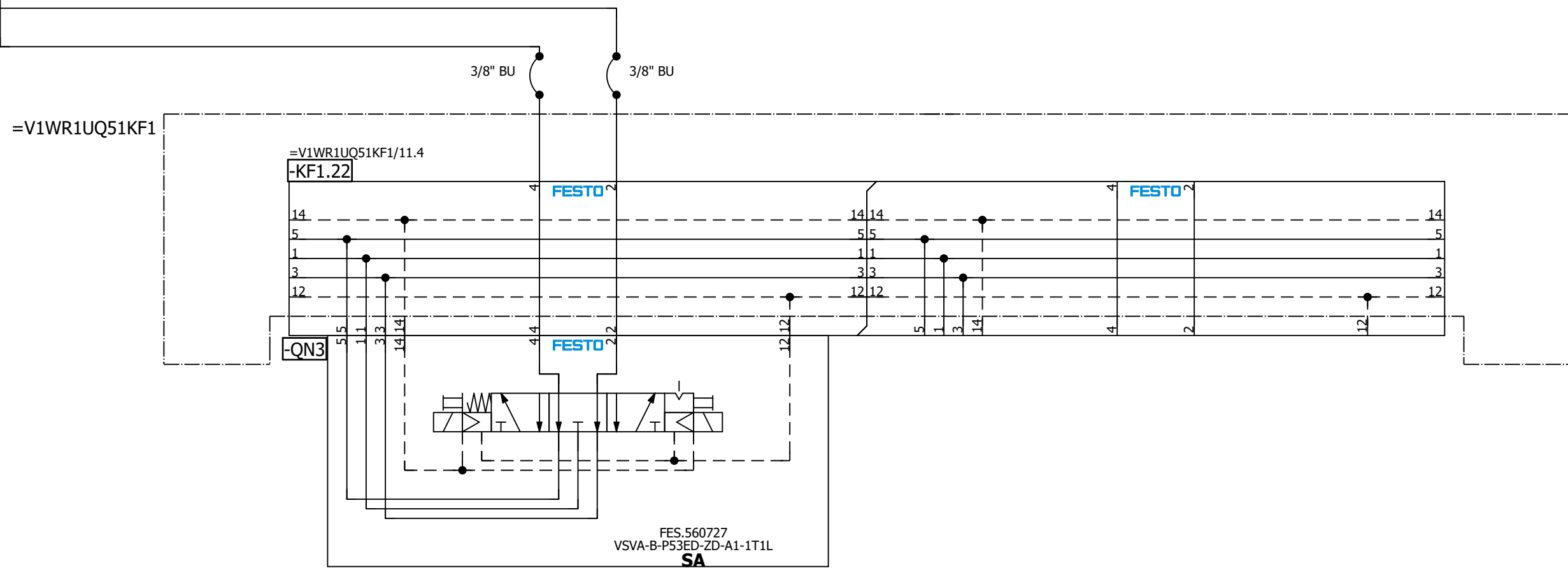
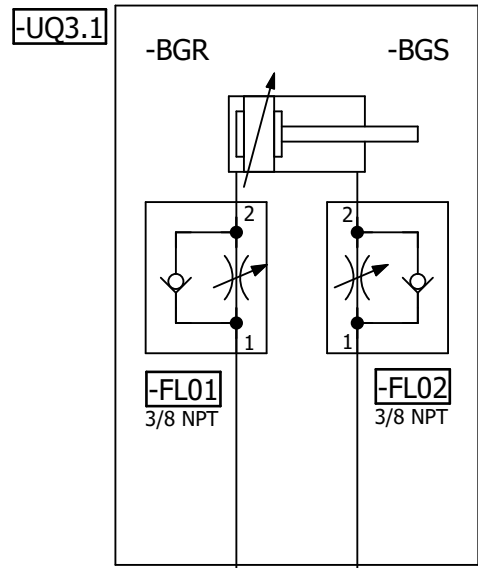

=V1WR1UQ51  
-UQ3-QN3.1  
Dump Clamp 3  
(RST)

=V1WR1UQ51  
-UQ3-QN3.2  
Dump Clamp 3  
(SET)

=V1WR1UQ51UQ2/1

=V1WR1UQ51UQ4/1

Date		1/4/2023	Volvo Trucks North America		Valiant TMS	Dump Clamp 3	Drawing name:		= V1WR1UQ51UQ3
Ed.		MKLEPADLO	P6700 Side Skin Roof Outer - Cell 2V08				=2V08&MFS-PNEU		+ V1WR1UQ51
Appr			Replacement of		Scale 1:1		Document type:		MFS
Original			Replaced by				Project nr:		22-16147
Modification	Date	Name	Original				Page		1
									112

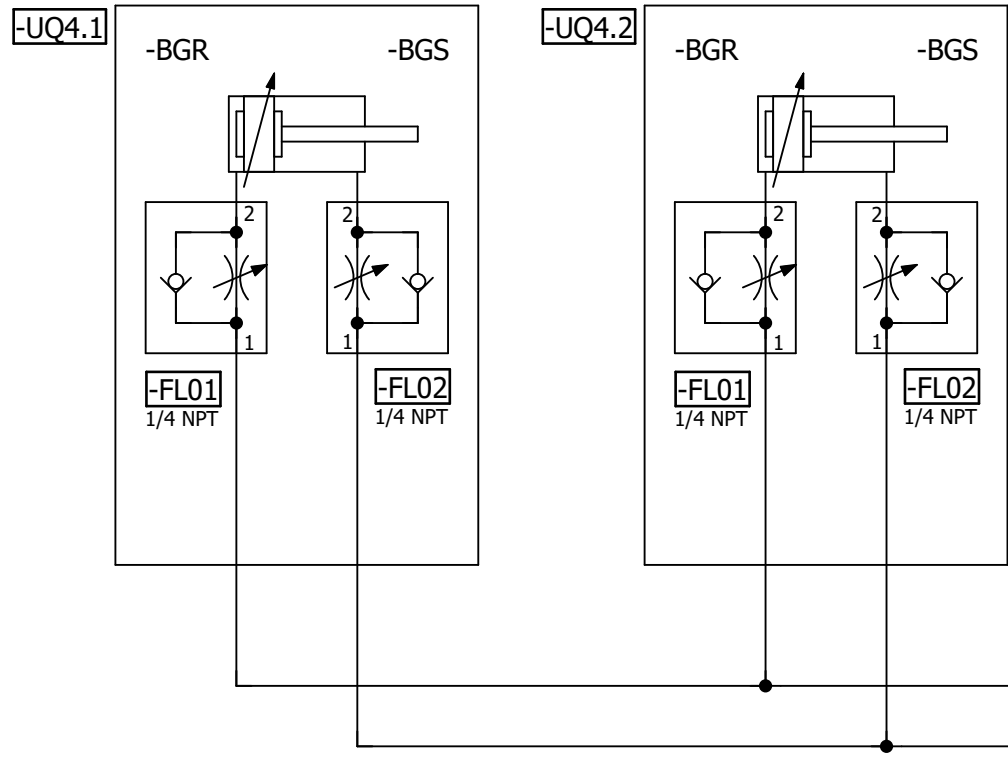

=V1WR1UQ51KF1

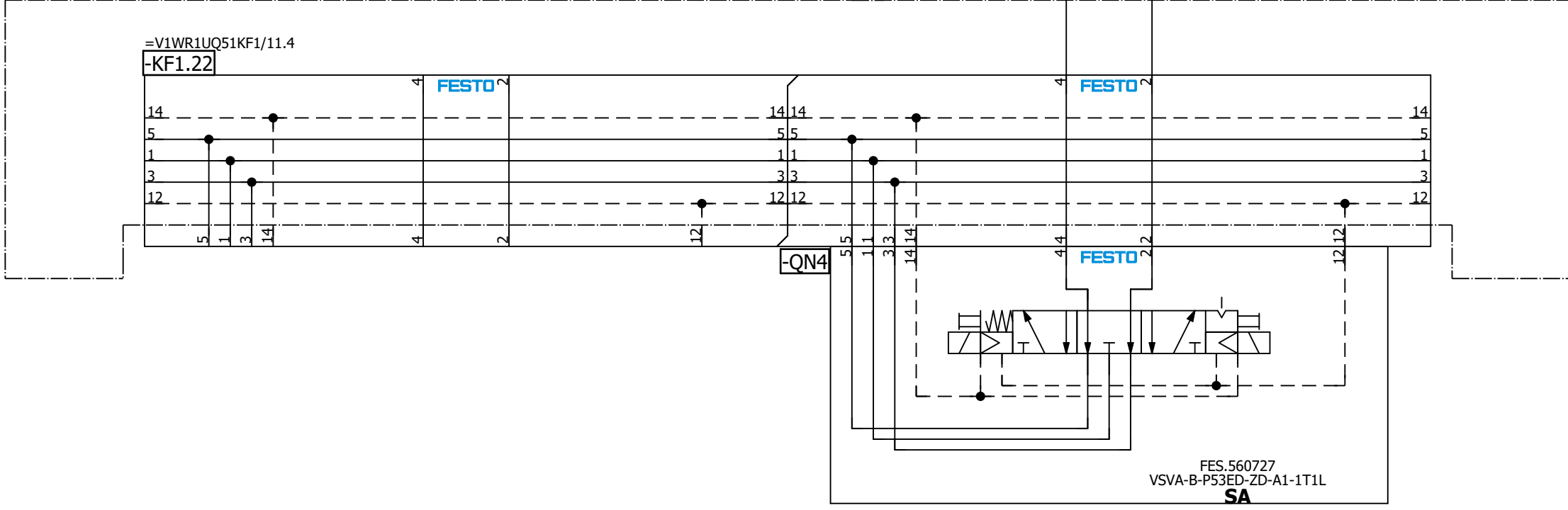

=V1WR1UQ51  
-UQ4-QN4.1  
Clamps 4  
(RST)

=V1WR1UQ51  
-UQ4-QN4.2  
Clamps 4  
(SET)

=V1WR1UQ51UQ5/1

=V1WR1UQ51UQ3/1			Date	1/4/2023	Volvo Trucks North America	Valiant TMS	Dump Clamp 4	Drawing name:	= V1WR1UQ51UQ4	
			Ed.	MKLEPADLO				=2V08&MFS-PNEU	+ V1WR1UQ51	
			Appr.		P6700 Side Skin Roof Outer - Cell 2V08			Document type:	MFS	
Modification	Date	Name	Original		Replacement of	Replaced by	Scale 1:1	Project nr:	22-16147	
									Page	1
										112

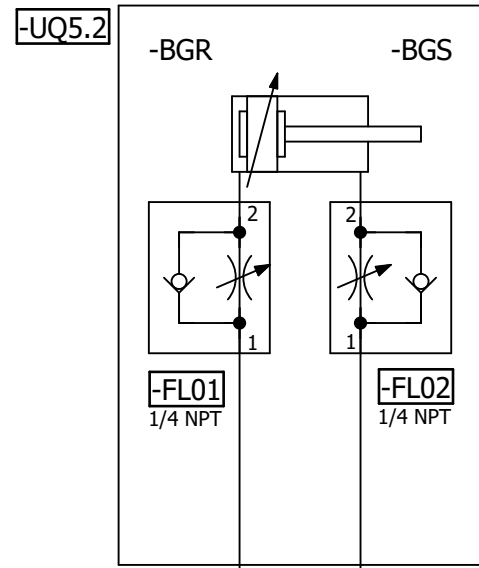
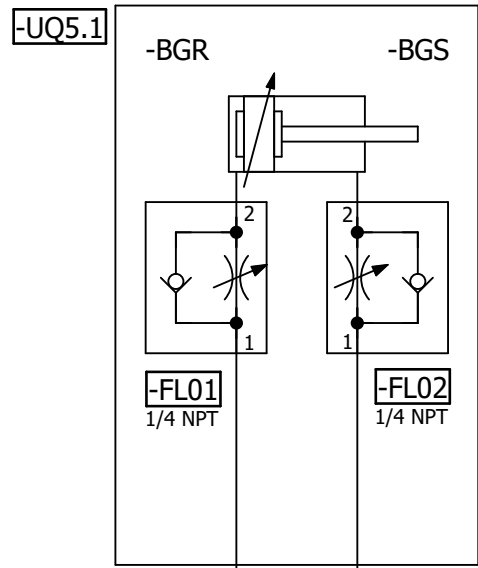

=V1WR1UQ51KF1

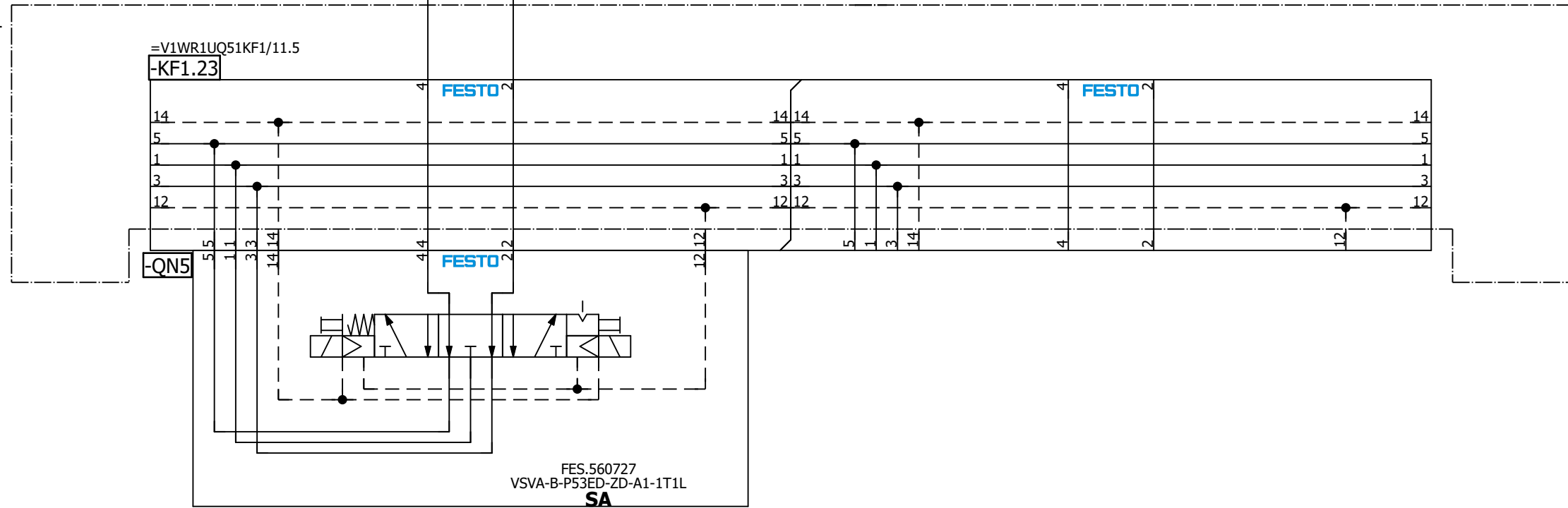

=V1WR1UQ51  
 -UQ5-QN5.1  
 Clamps 5  
 (RST)

=V1WR1UQ51  
 -UQ5-QN5.2  
 Clamps 5  
 (SET)

=V1WR1UQ51UQ4/1

=V1WR1UQ51UQ6/1

Date		1/4/2023	Volvo Trucks North America		Valiant TMS	Clamps 5	Drawing name:		= V1WR1UQ51UQ5
Ed.		MKLEPADLO	P6700 Side Skin Roof Outer - Cell 2V08				=2V08&MFS-PNEU		+ V1WR1UQ51
Appr			Replacement of		Scale 1:1		Document type:		MFS
Original			Replaced by				Project nr:		22-16147
Modification	Date	Name	Original				Page		1
									112

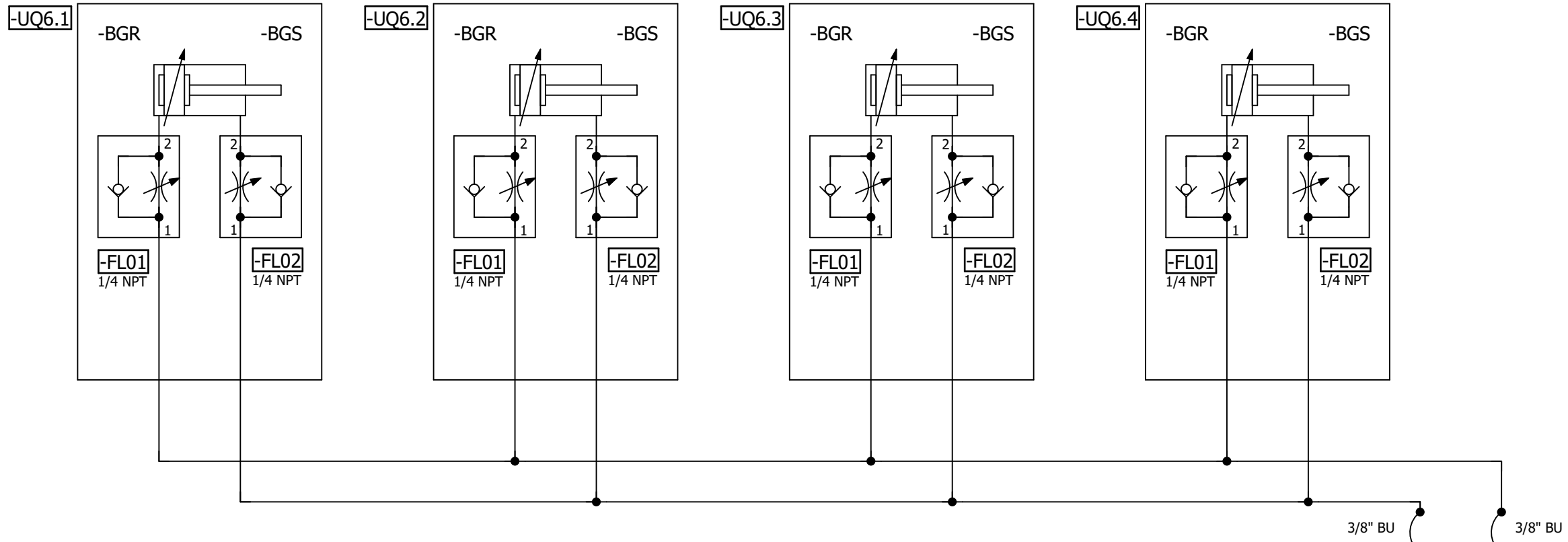

=V1WR1UQ51KF1

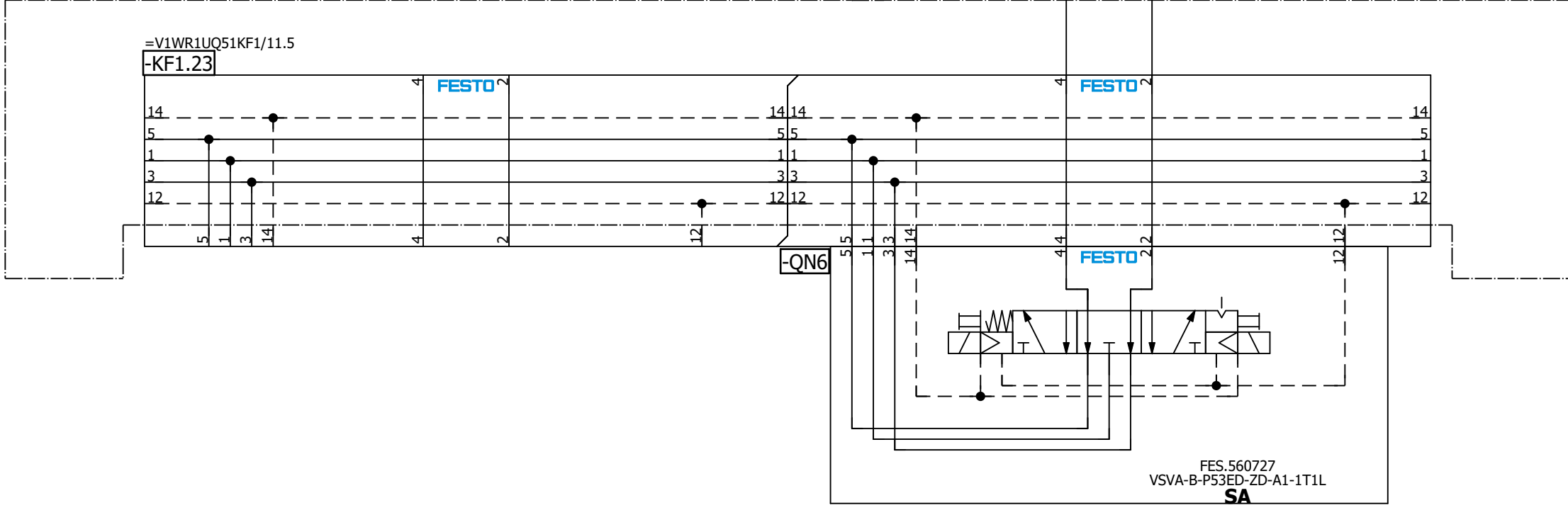

=V1WR1UQ51  
-UQ6-QN6.1  
Clamps 6  
(RST)

=V1WR1UQ51  
-UQ6-QN6.2  
Clamps 6  
(SET)

=V1WR1UQ51UQ7/1

=V1WR1UQ51UQ5/1			Date	1/4/2023	Volvo Trucks North America	Valiant TMS	Clamps 6	Drawing name:	= V1WR1UQ51UQ6	
			Ed.	MKLEPADLO		Scale 1:1		Drawing type:	= 2V08&MFS-PNEU	
			Appr.					Replacement of	Replaced by	Document type:
Modification	Date	Name	Original					Project nr:	22-16147	
									Page	1
										112

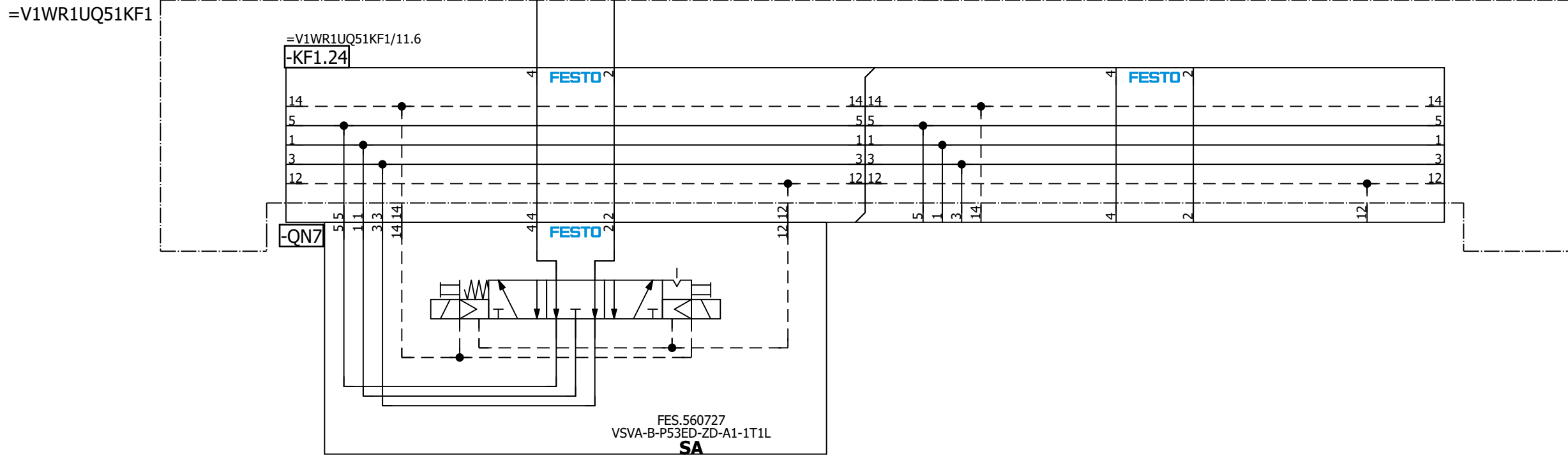
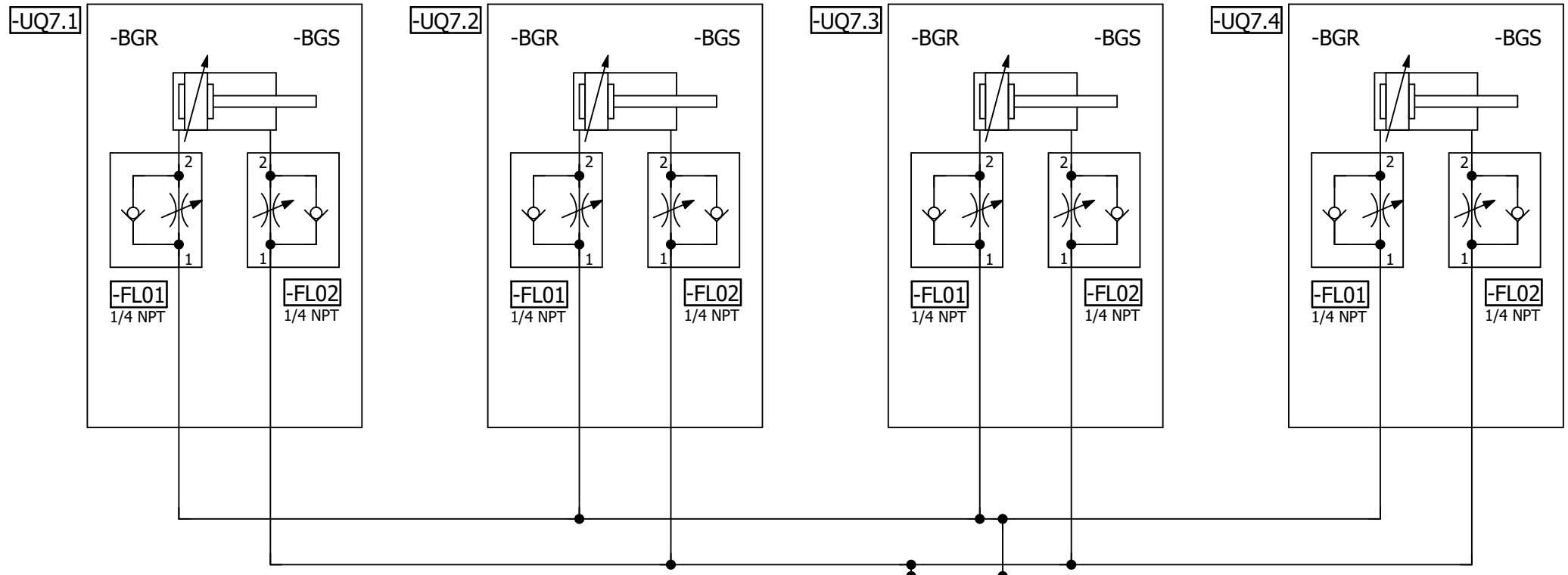

=V1WR1UQ51  
-UQ7-QN7.1  
Clamps 7  
(RST)

=V1WR1UQ51  
-UQ7-QN7.2  
Clamps 7  
(SET)

=V1WR1UQ51UQ6/1 =V1WR1UQ51UQ8/1

Date		1/4/2023	Volvo Trucks North America		Valiant TMS	Clamps 7	Drawing name:		= V1WR1UQ51UQ7
Ed.		MKLEPADLO	P6700 Side Skin Roof Outer - Cell 2V08				=2V08&MFS-PNEU		+ V1WR1UQ51
Appr			Replacement of		Scale 1:1		Document type:		MFS
Original			Replaced by				Project nr:		22-16147
Modification	Date	Name	Original				Page		1
									112

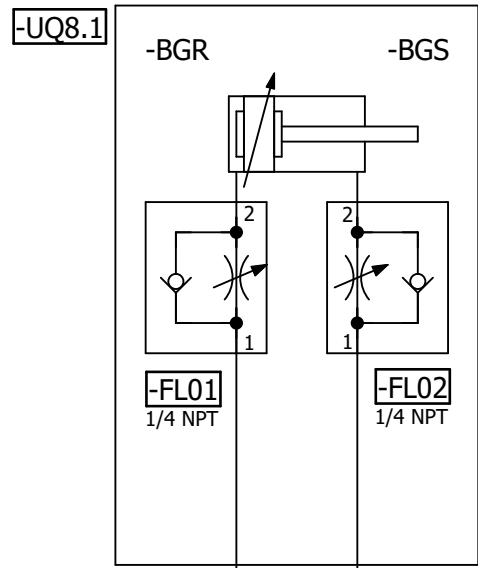

=V1WR1UQ51KF1

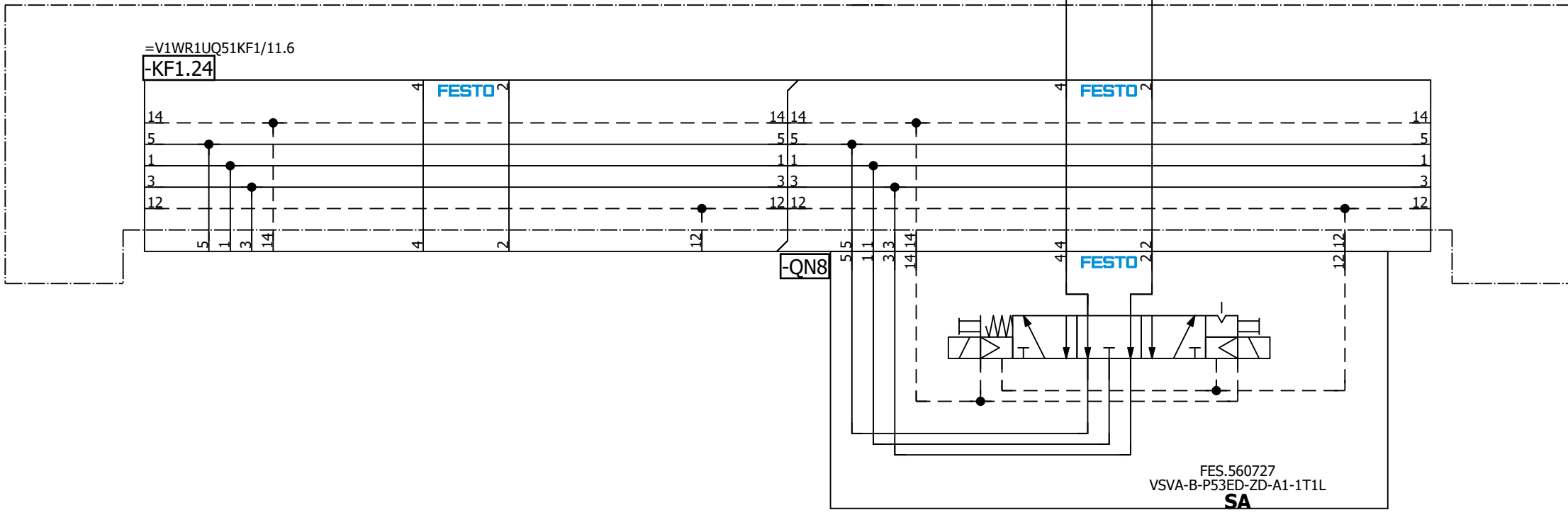

=V1WR1UQ51  
-UQ8-QN8.1  
Clamp 8  
(RST)

=V1WR1UQ51  
-UQ8-QN8.2  
Clamp 8  
(SET)

=V1WR1UQ51UQ9/1

=V1WR1UQ51UQ7/1			Date	1/4/2023	Volvo Trucks North America	Valiant TMS	Clamp 8	Drawing name:	= V1WR1UQ51UQ8	
			Ed.	MKLEPADLO		Scale 1:1	Document type:		Project nr:	
			Appr				MFS	22-16147	Page	1
Modification	Date	Name	Original		Replacement of	Replaced by		= V1WR1UQ51UQ8 + V1WR1UQ51		
								Page		1
								Page		112

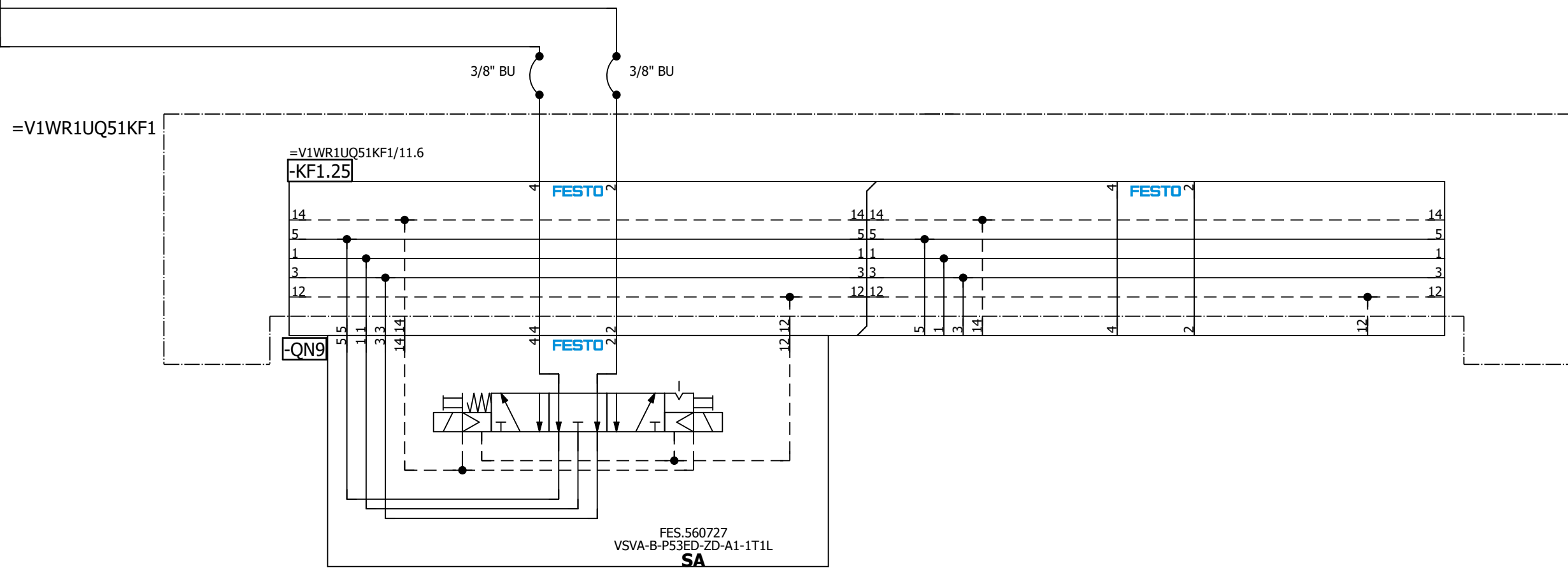
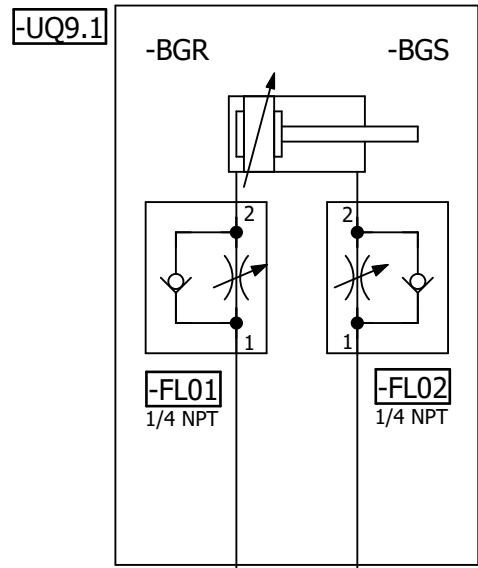

=V1WR1UQ51  
-UQ9-QN9.1  
Clamp 9  
(RST)

=V1WR1UQ51  
-UQ9-QN9.2  
Clamp 9  
(SET)

=V1WR1UQ51UQ8/1

=V1WR1UQ51UQ10/1

Date		1/4/2023	Volvo Trucks North America		Valiant TMS	Clamp 9	Drawing name:		= V1WR1UQ51UQ9	
Ed.		MKLEPADLO	P6700 Side Skin Roof Outer - Cell 2V08				=2V08&MFS-PNEU		+ V1WR1UQ51	
Appr			Replacement of		Scale 1:1		Document type:	Project nr:	22-16147	
Modification	Date	Name	Original	Replaced by			MFS			112



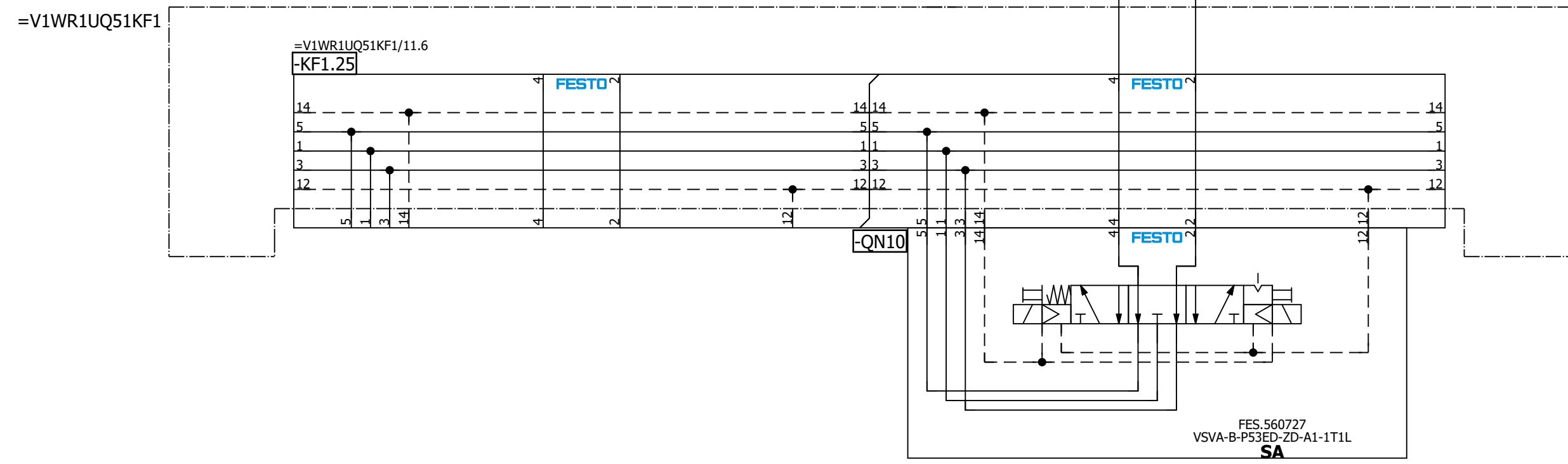
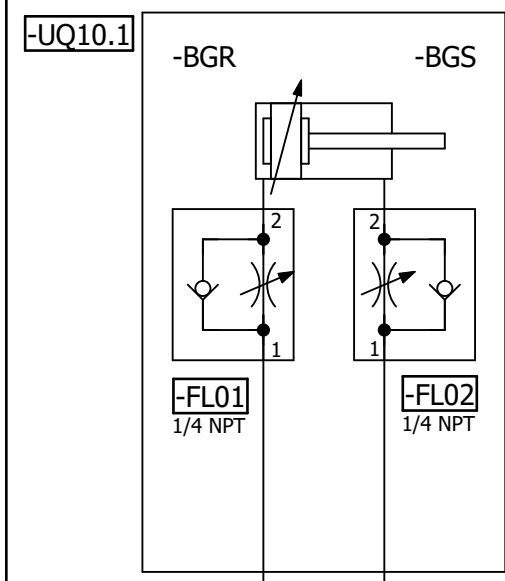

=V1WR1UQ51  
-UQ10-QN10.1  
Clamp 10  
(RST)

=V1WR1UQ51  
-UQ10-QN10.2  
Clamp 10  
(SET)

=V1WR1UQ51UQ9/1			Date	1/4/2023	Volvo Trucks North America	Valiant TMS	Clamp 10	Drawing name:		= V1WR1UQ51UQ10		
			Ed.	MKLEPADLO				=2V08&MFS-PNEU		+ V1WR1UQ51		
Modification			Appr.		P6700 Side Skin Roof Outer - Cell 2V08	Scale 1:1	Document type:		MFS	Project nr: 22-16147	Page	1
			Date				Original		Replacement of		Replaced by	





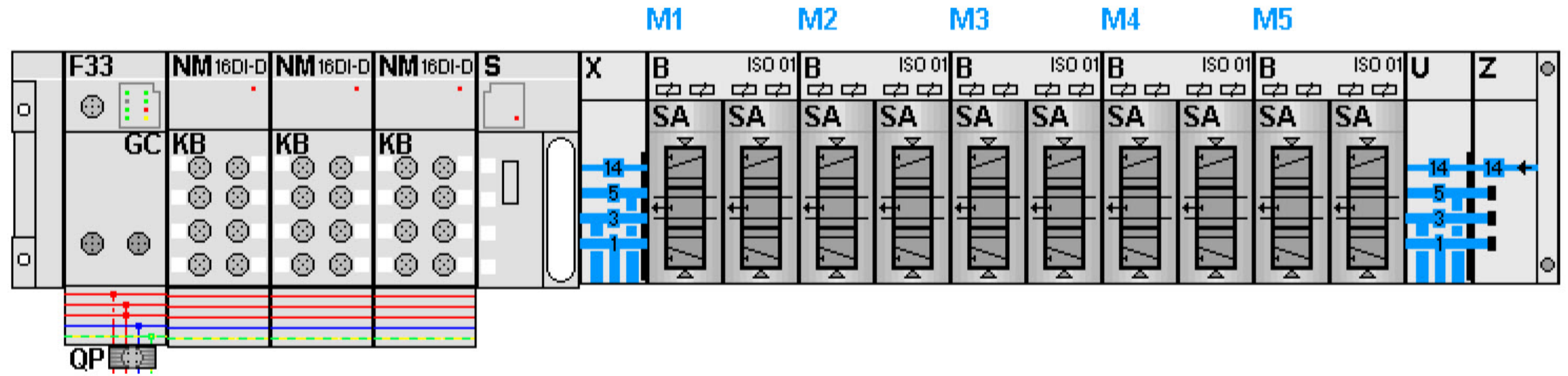

KF1.0

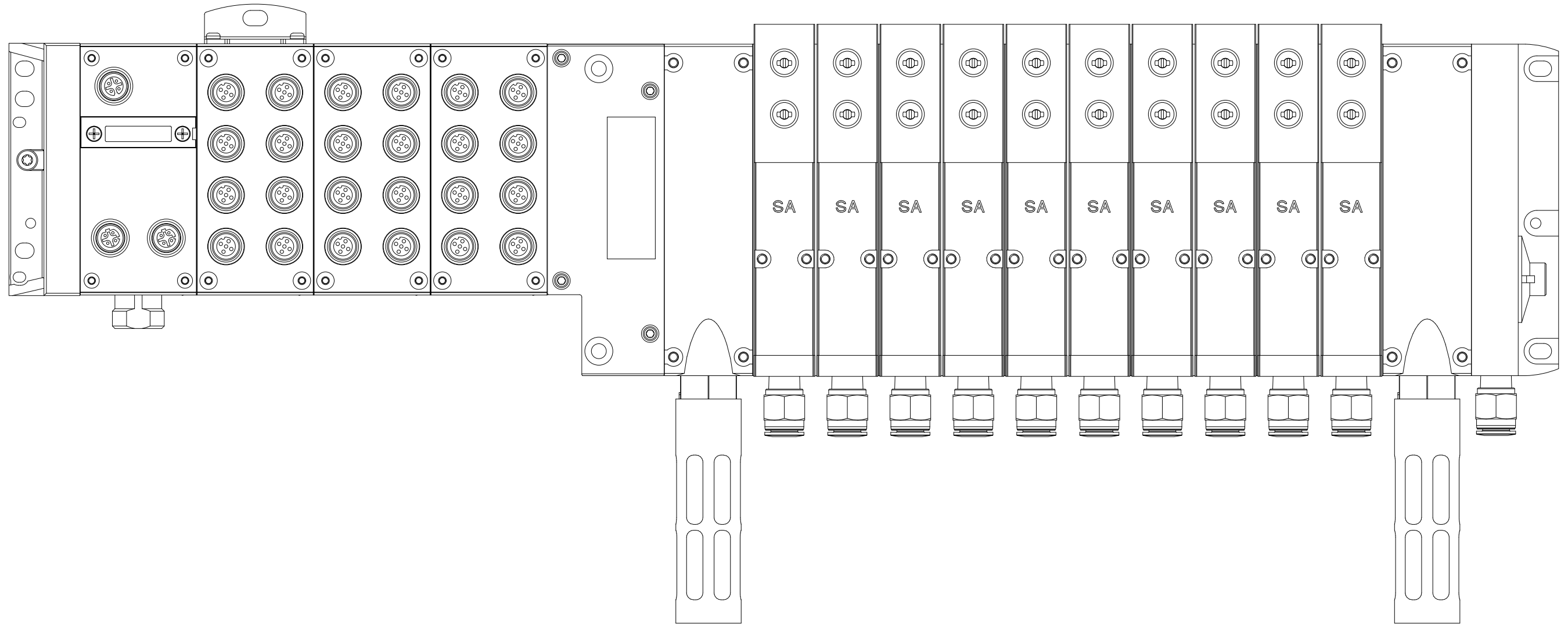

=V1WR1UQ51UQ12+.WR1UQ51/1

Date		1/4/2023		Volvo Trucks North America		Valiant TMS		AIR SUPPLY CONFIGURATION		Drawing name:		= V1WR1UQ52KF1	
Ed.		MKLEPADLO		P6700 Side Skin Roof Outer - Cell 2V08		Scale 1:1				=2V08&MFS-PNEU		+ V1WR1UQ52	
Appr				Replacement of		Replaced by				Document type:		Project nr:	
Original										MFS		22-16147	
Modification		Date		Name								Page	
												5	
												112	

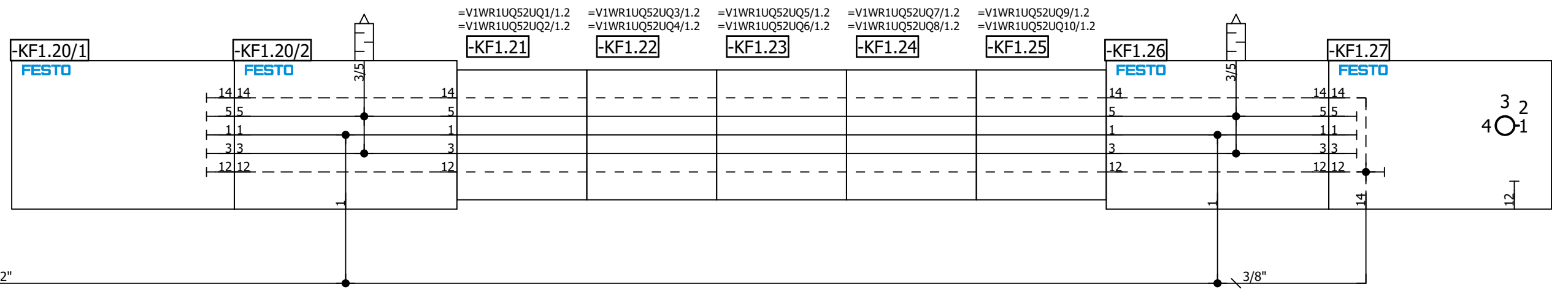
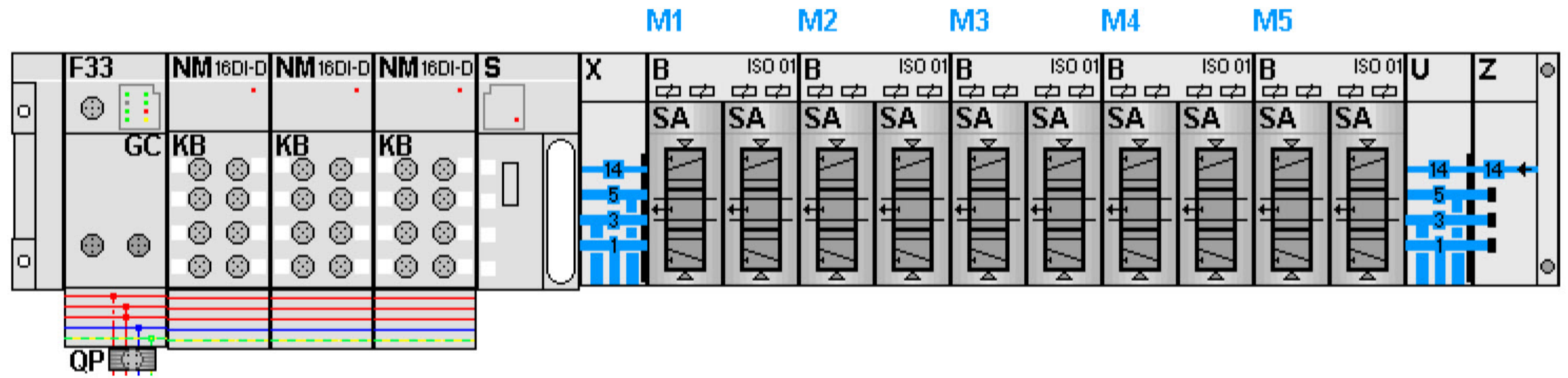

Date		1/4/2023	Volvo Trucks North America		Valiant TMS	AIR SUPPLY	Drawing name:		= V1WR1UQ52KF1	
Ed.		MKLEPADLO	P6700 Side Skin Roof Outer - Cell 2V08				=2V08&MFS-PNEU		+ V1WR1UQ52	
Appr.			Replacement of		Replaced by		Document type:		Project nr:	
Original							MFS		22-16147	
Modification		Date	Name	Original	Scale 1:1				Page 11	
									112	





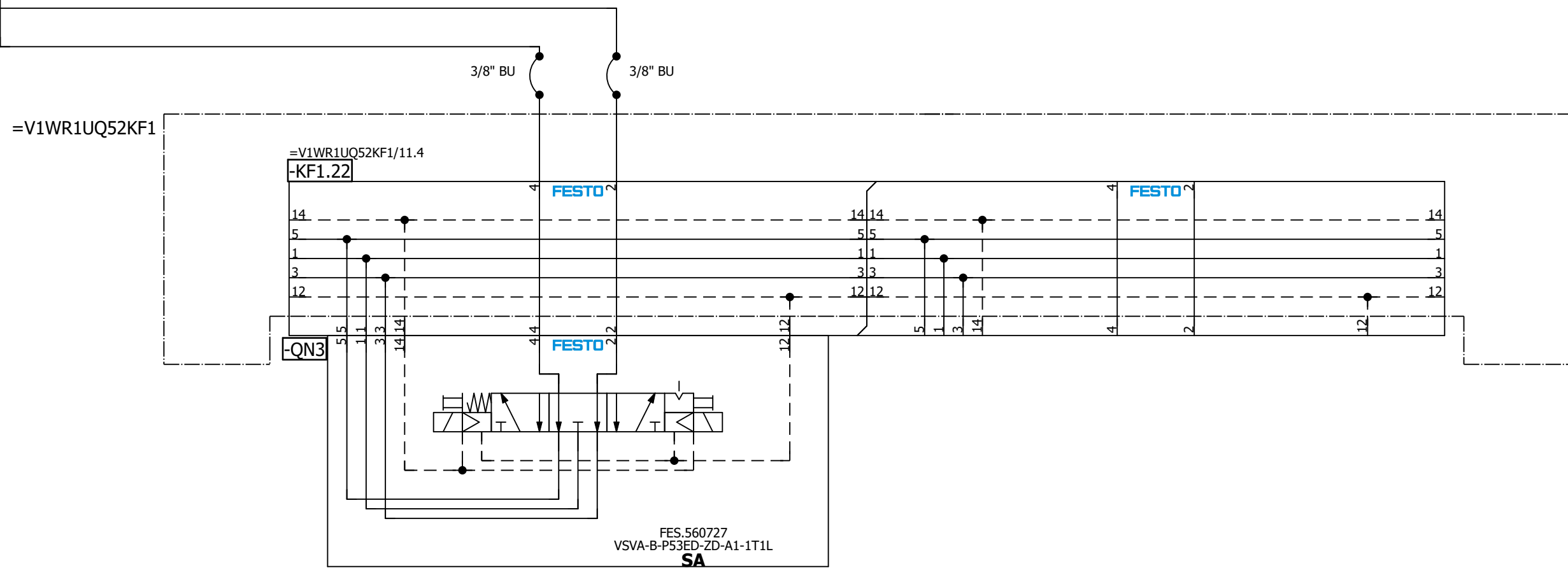
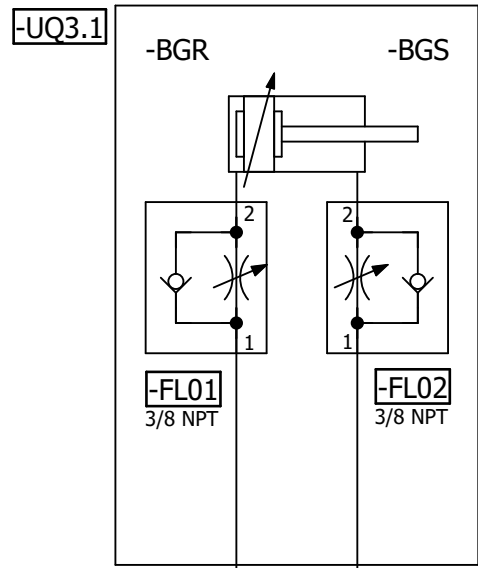

=V1WR1UQ52  
-UQ3-QN3.1  
Dump Clamp 3  
(RST)

=V1WR1UQ52  
-UQ3-QN3.2  
Dump Clamp 3  
(SET)

=V1WR1UQ52UQ2/1

=V1WR1UQ52UQ4/1

Date		1/4/2023	Volvo Trucks North America		Valiant TMS	Dump Clamp 3	Drawing name:		= V1WR1UQ52UQ3
Ed.		MKLEPADLO	P6700 Side Skin Roof Outer - Cell 2V08				=2V08&MFS-PNEU		+ V1WR1UQ52
Appr			Replacement of		Scale 1:1		Document type:		MFS
Original			Replaced by				Project nr:		22-16147
Modification	Date	Name	Original				Page		1
									112





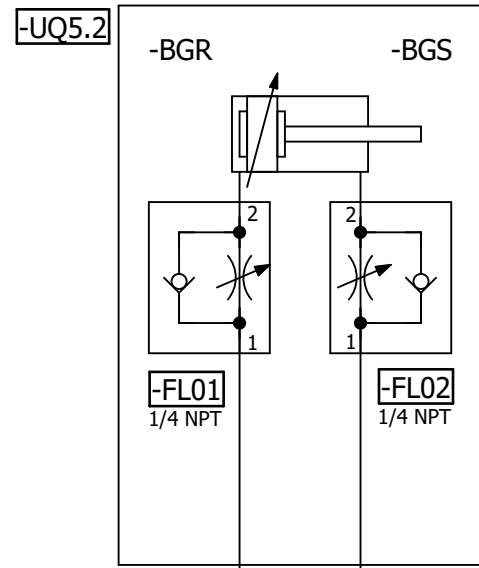
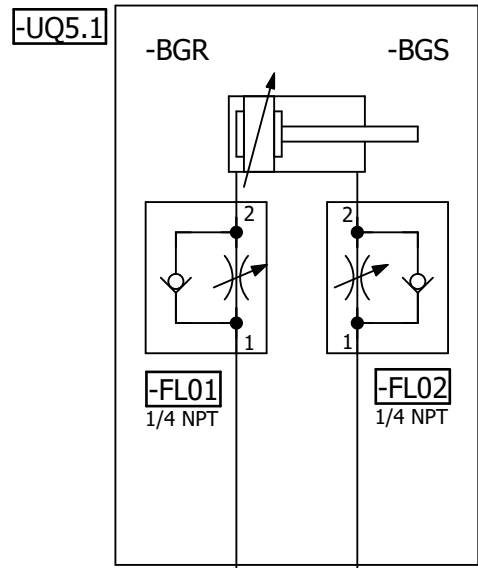

=V1WR1UQ52KF1

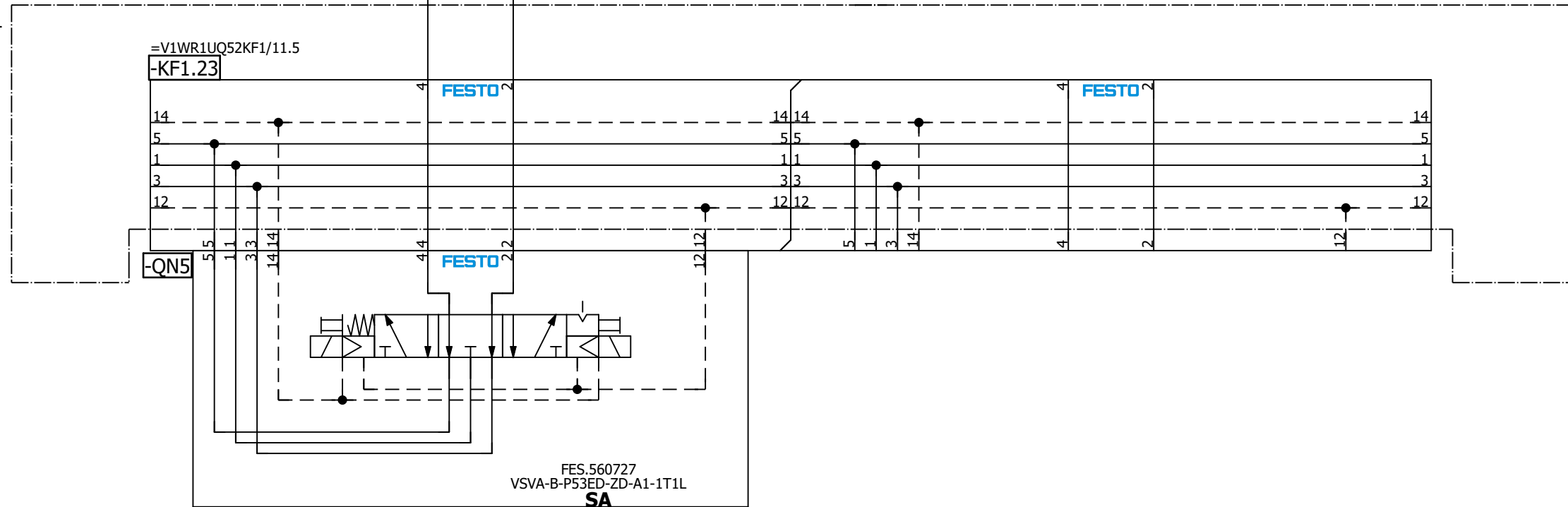

=V1WR1UQ52  
 -UQ5-QN5.1  
 Clamps 5  
 (RST)

=V1WR1UQ52  
 -UQ5-QN5.2  
 Clamps 5  
 (SET)

=V1WR1UQ52UQ4/1

=V1WR1UQ52UQ6/1

Date		1/4/2023	Volvo Trucks North America		Valiant TMS	Clamps 5	Drawing name:		= V1WR1UQ52UQ5
Ed.		MKLEPADLO	P6700 Side Skin Roof Outer - Cell 2V08				=2V08&MFS-PNEU		+ V1WR1UQ52
Appr			Replacement of		Scale 1:1		Document type:		MFS
Original			Replaced by				Project nr:		22-16147
Modification	Date	Name	Original				Page		1
									112





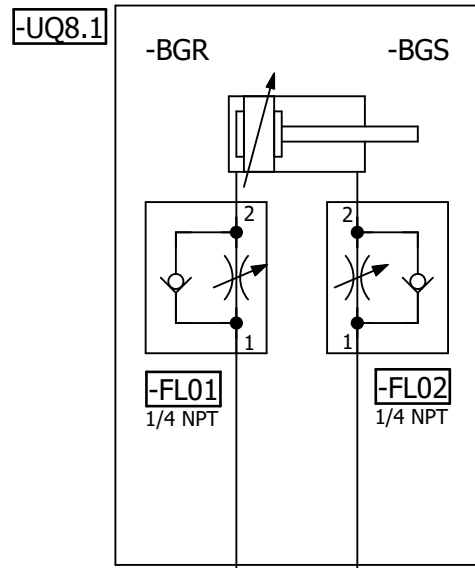

=V1WR1UQ52KF1

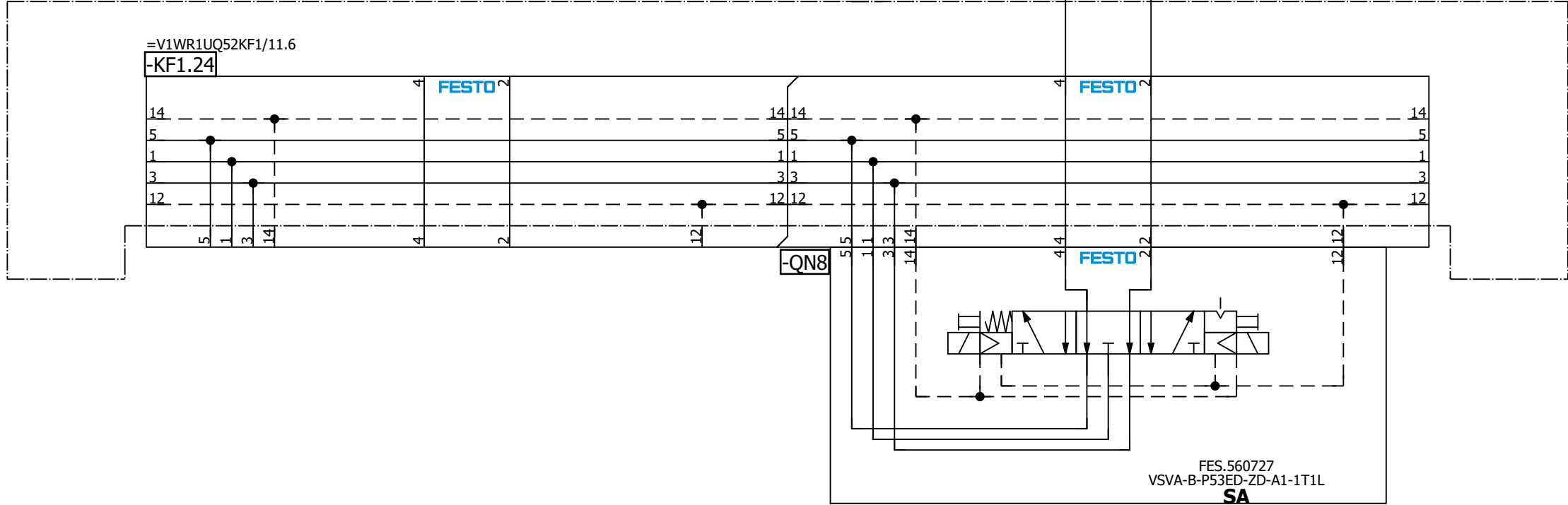

=V1WR1UQ52  
-UQ8-QN8.1  
Clamp 8  
(RST)

=V1WR1UQ52  
-UQ8-QN8.2  
Clamp 8  
(SET)

=V1WR1UQ52UQ9/1

=V1WR1UQ52UQ7/1			Date	1/4/2023	Volvo Trucks North America	Valiant TMS	Clamp 8	Drawing name:	= V1WR1UQ52UQ8	
			Ed.	MKLEPADLO		Scale 1:1		Drawing type:	= 2V08&MFS-PNEU	
			Appr					Replacement of	Replaced by	Document type:
Modification	Date	Name	Original					Project nr:	22-16147	
									Page	1
										112



=V1WR1UQ52KF1

=V1WR1UQ52KF1/11.6  
-KF1.25

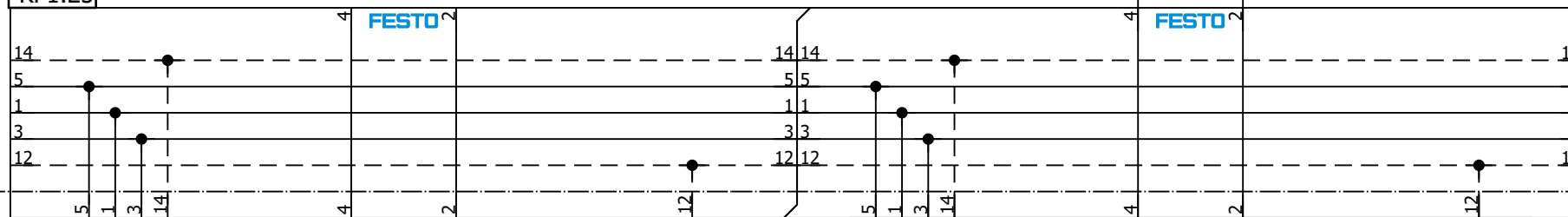

-QN10

FESTO

FESTO

FESTO

FES.560727  
VSVA-B-P53ED-ZD-A1-1T1L  
SA

=V1WR1UQ52  
-UQ10-QN10.1  
Spare  
(RST)

=V1WR1UQ52  
-UQ10-QN10.2  
Spare  
(SET)

=V1WR1UQ52UQ9/1

=V2AR181XQ93+KH1/1

Date		1/11/2023		Volvo Trucks North America		Valiant TMS		Spare		Drawing name:		= V1WR1UQ52UQ10	
Ed.		MKLEPADLO		P6700 Side Skin Roof Outer - Cell 2V08		Scale 1:1				Document type:		+ V1WR1UQ52	
Appr.				Replacement of		Replaced by				Project nr:		Page	
Original										22-16147		1	
Modification		Date		Name		Original				MFS		112	

A2

/ +V2AR181XQ93KH1-P1  
=KH0+KH0/1.1

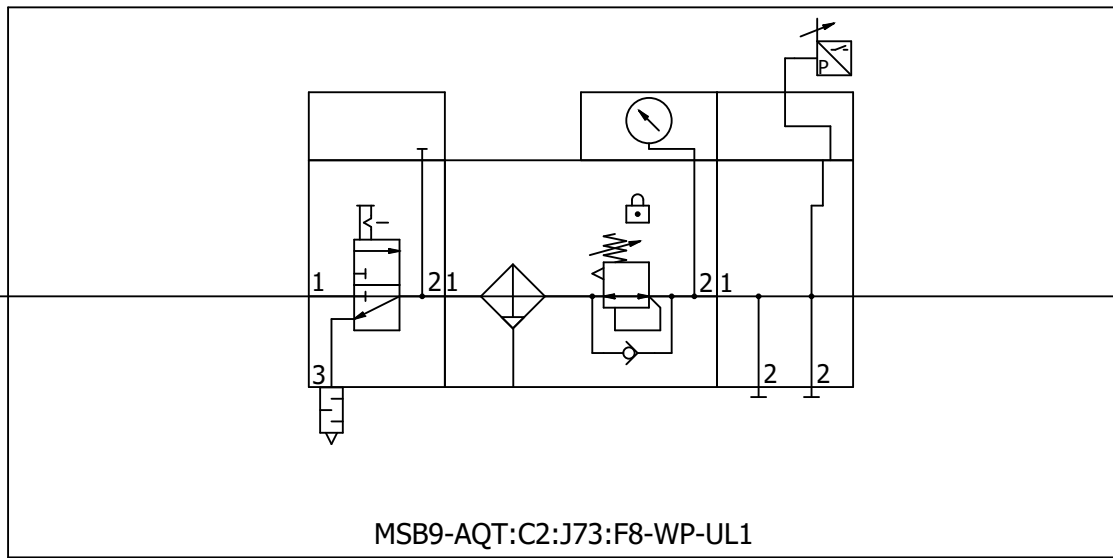

+V2AR181XQ93KH1-P1 /  
Fume Extractor

=V1WR1UQ52UQ10+V1WR1UQ52/1

=V2LB1/1

		Date	1/4/2023	Volvo Trucks North America	Valiant TMS	Incoming air supply (Fume Extractor)	Drawing name:		= V2AR181XQ93
		Ed.	MKLEPADLO	P6700 Side Skin Roof Outer - Cell 2V08			=2V08&MFS-PNEU		+ KH1
		Appr			Scale 1:1		Document type:	Project nr:	Page
Modification	Date	Name	Original	Replacement of			Replaced by	MFS	22-16147
									112



A2

=KH0+KH0/1.7 / +V2LB1KH1-P1

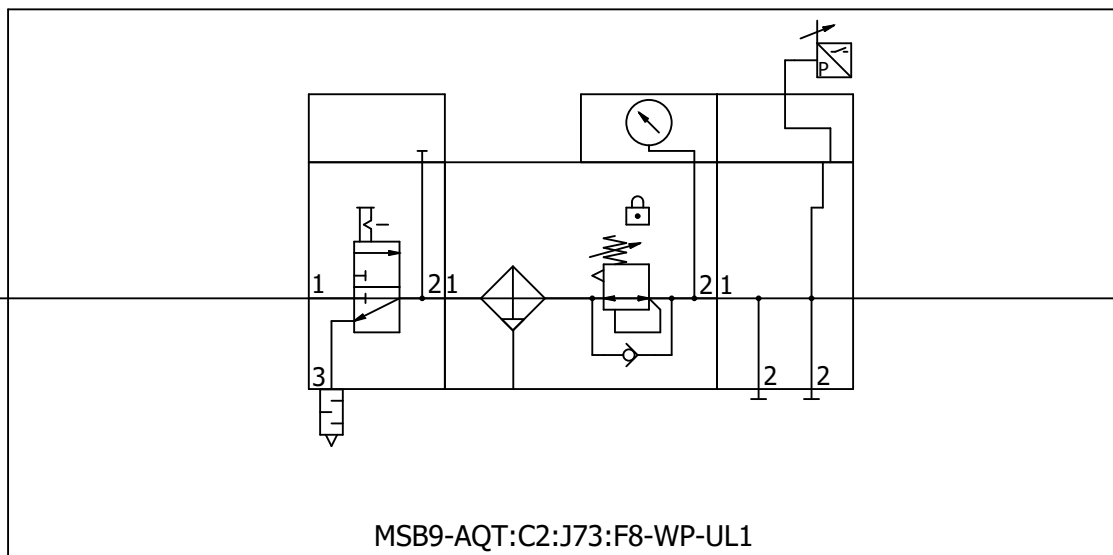

1"

+V2LB1-P1 / =V2LB1KF1+V2LB1/11.0

=V2AR181XQ93/1

=V2LB1KF1+V2LB1/5

		Date	1/4/2023	Volvo Trucks North America			Valiant TMS	Incoming air supply (Fixture)	Drawing name:		= V2LB1
		Ed.	MKLEPADLO	P6700 Side Skin Roof Outer - Cell 2V08						=2V08&MFS-PNEU	
Modification	Date	Name	Original	Replacement of	Replaced by		Scale 1:1	Document type:	Project nr:		Page
								MFS	22-16147		1
											112

M1

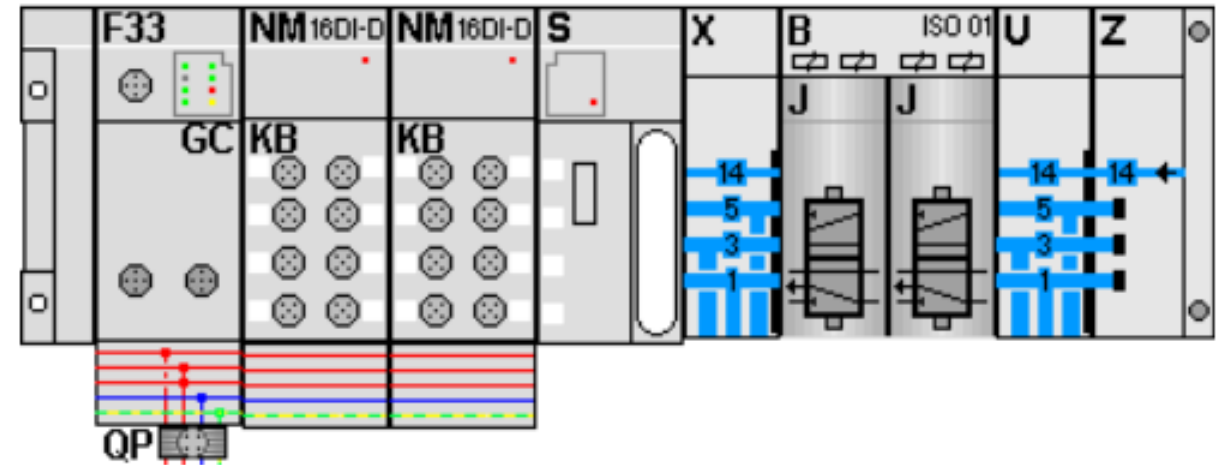

KF1.0

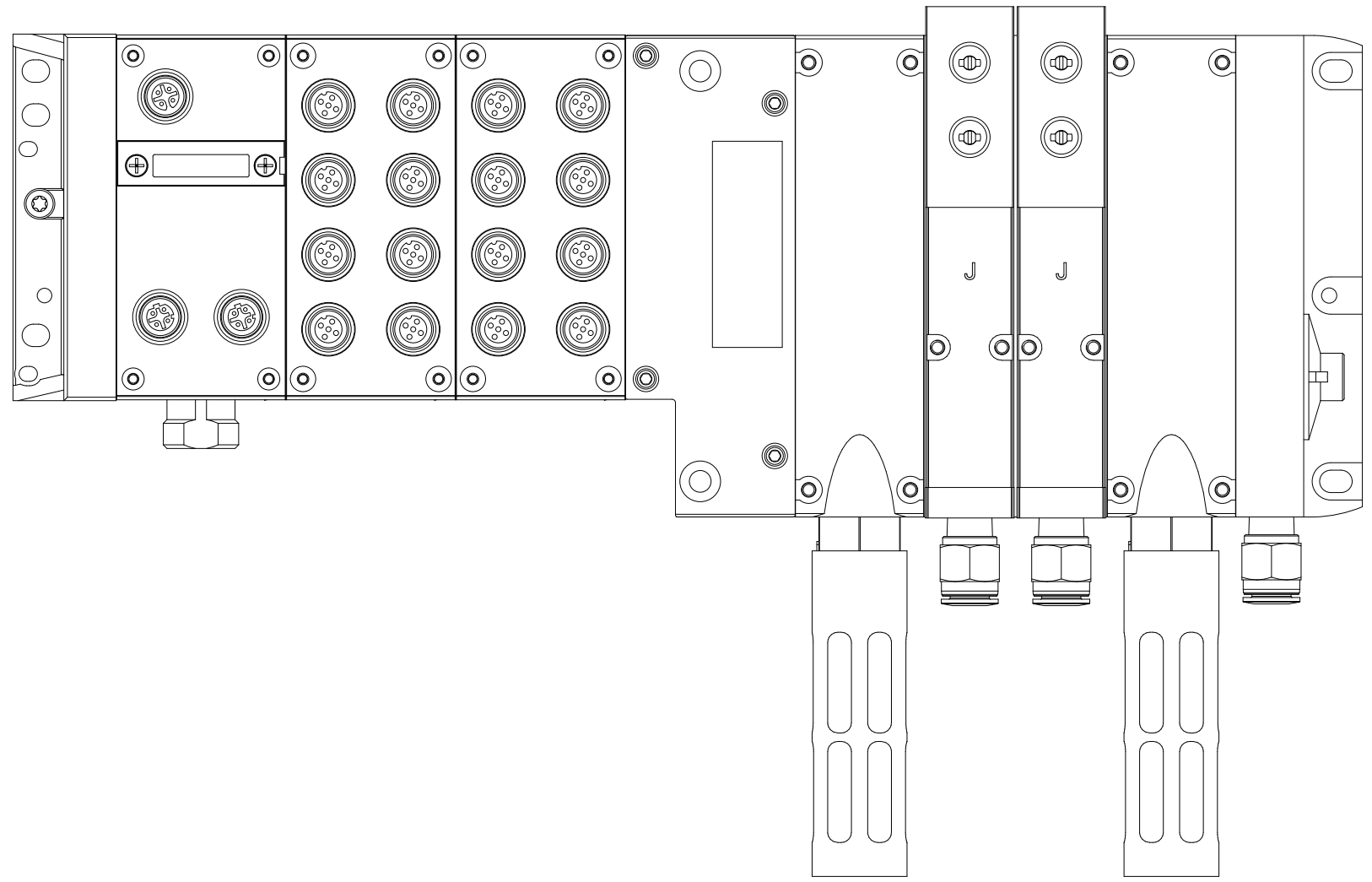

=V2LB1+KH1/1

11

Date		1/4/2023	Volvo Trucks North America		Valiant TMS	AIR SUPPLY CONFIGURATION	Drawing name:		= V2LB1KF1
Ed.		MKLEPADLO	P6700 Side Skin Roof Outer - Cell 2V08				=2V08&MFS-PNEU		+ V2LB1
Appr			Replacement of		Scale 1:1	Document type:	Project nr:	MFS	22-16147
Modification	Date	Name	Original	Replaced by					
									112

M1

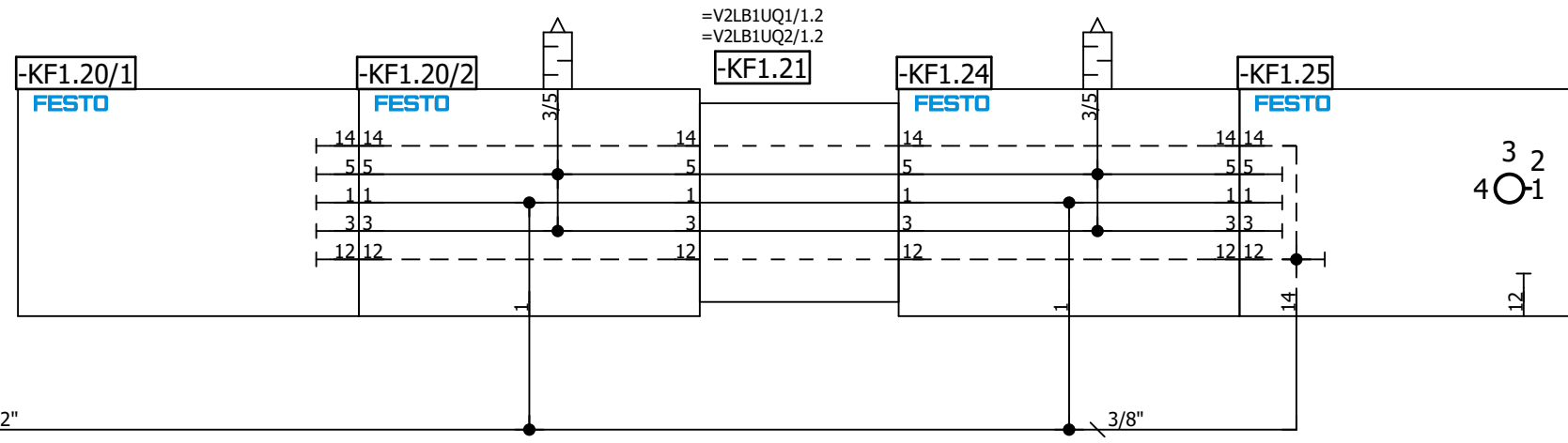
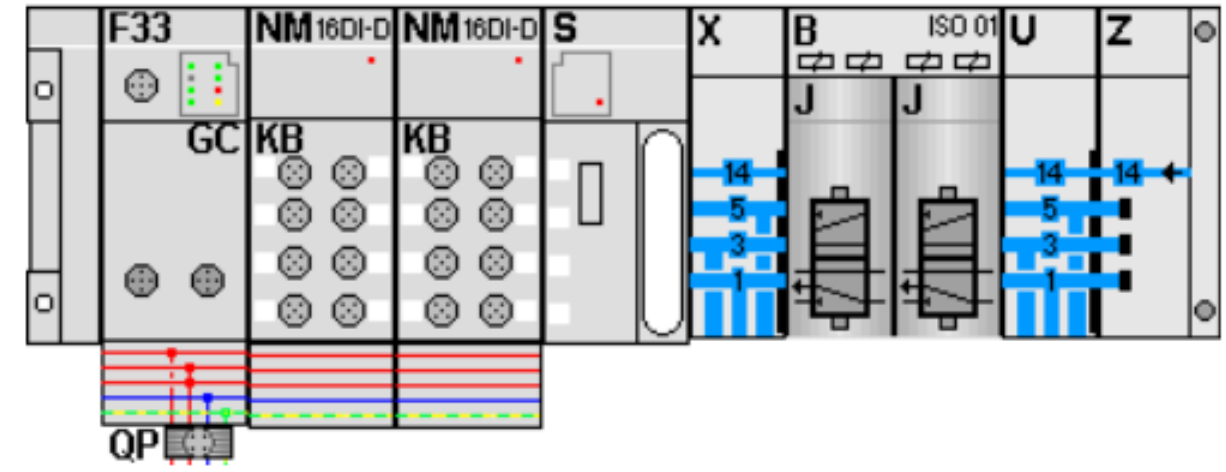

5

=V2LB1UQ1/1

Date		1/4/2023	Volvo Trucks North America		Valiant TMS	AIR SUPPLY	Drawing name:		= V2LB1KF1
Ed.		MKLEPADLO	P6700 Side Skin Roof Outer - Cell 2V08				=2V08&MFS-PNEU		+ V2LB1
Appr			Replacement of		Scale 1:1	Document type:	Project nr:	Page	11
Modification	Date	Name	Original	Replaced by					MFS



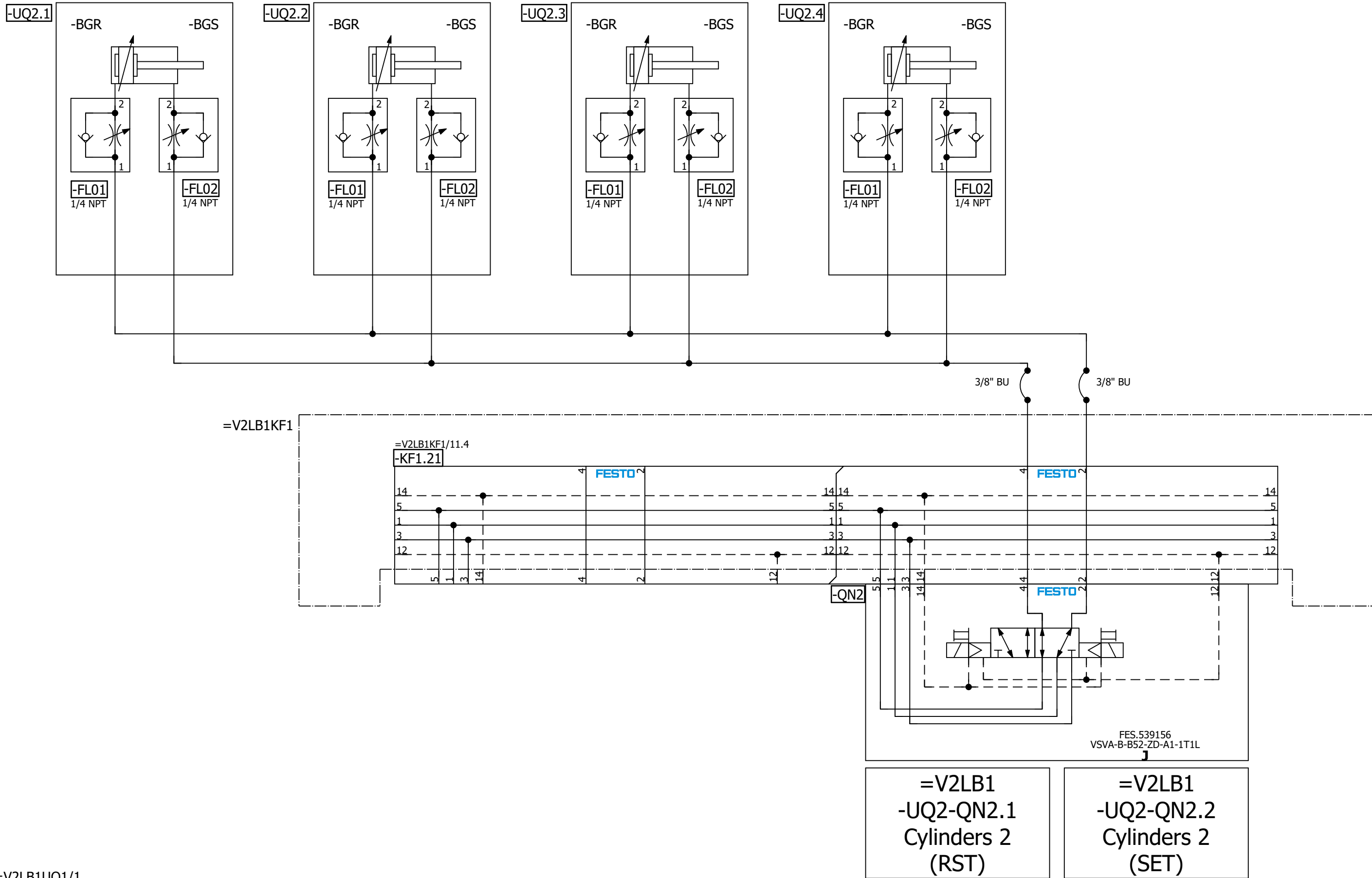

=V2LB1UQ1/1

=V2WR1+KH1/1

Date		1/4/2023	Volvo Trucks North America		Valiant TMS	Cylinders 2	Drawing name:		= V2LB1UQ2
Ed.		MKLEPADLO	P6700 Side Skin Roof Outer - Cell 2V08				=2V08&MFS-PNEU		+ V2LB1
Appr			Replacement of		Scale 1:1		Document type:		Project nr:
Original			Replaced by				MFS		22-16147
Modification		Date	Name	Original					112



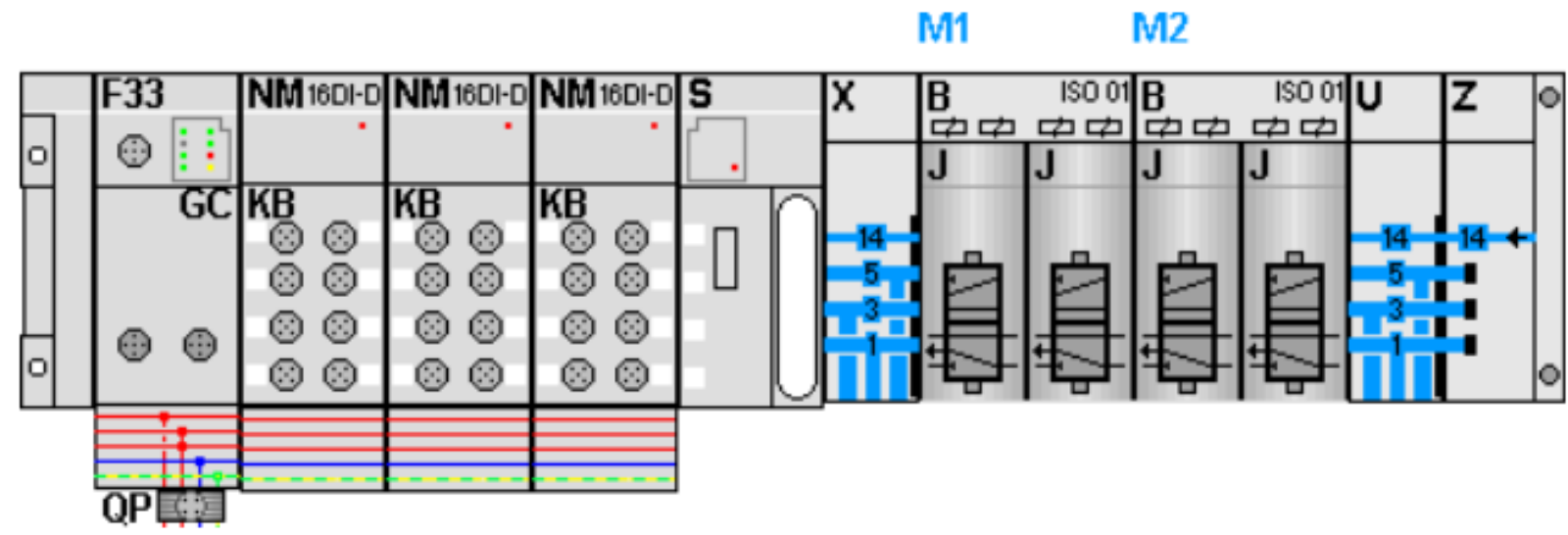

KF1.0

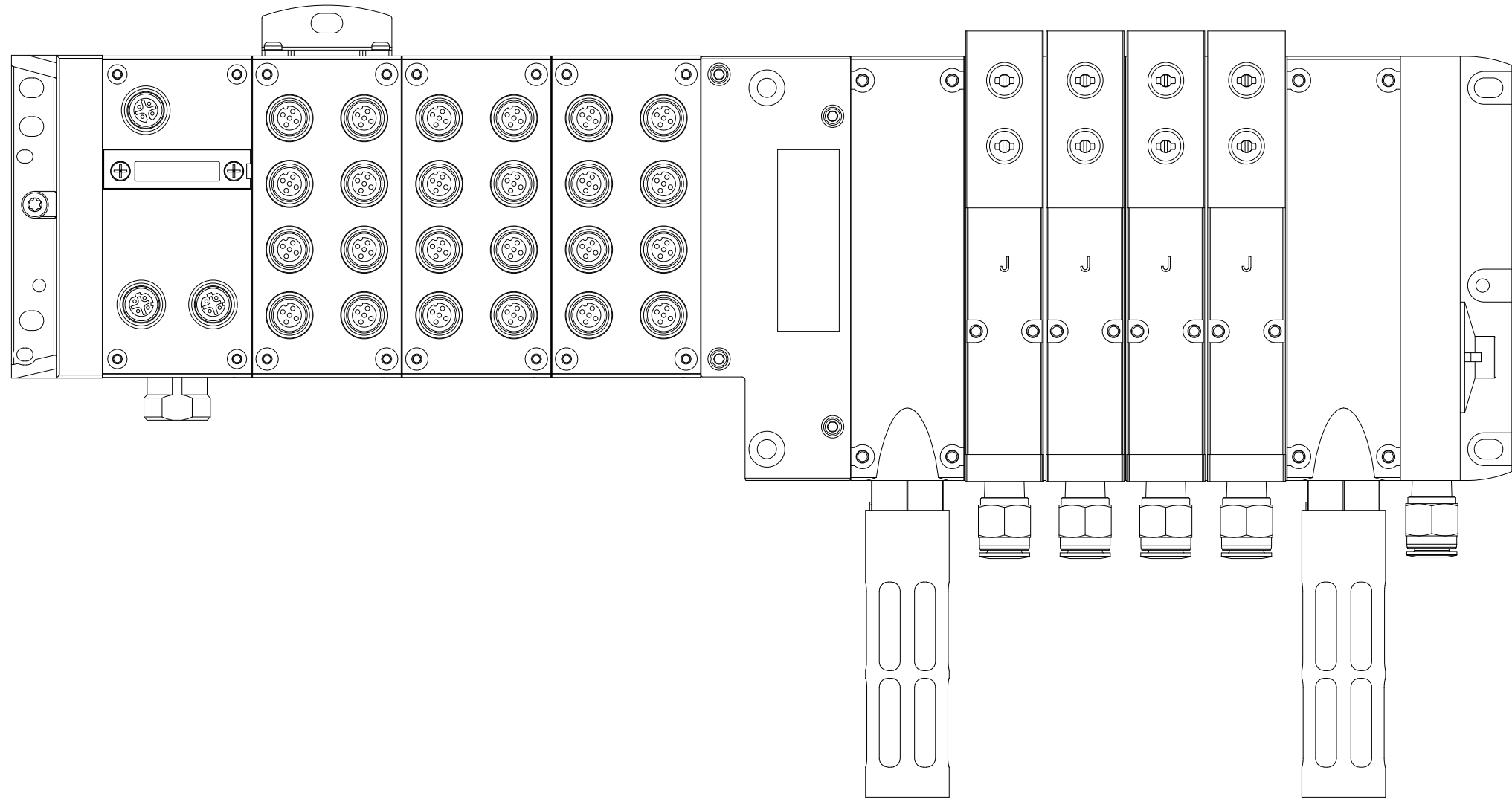

=V2WR1+KH1/1

Date		1/4/2023	Volvo Trucks North America		Valiant TMS	AIR SUPPLY CONFIGURATION	Drawing name:		= V2WR1UQ51KF1
Ed.		MKLEPADLO	P6700 Side Skin Roof Outer - Cell 2V08				=2V08&MFS-PNEU		+ V2WR1UQ51
Appr			Replacement of		Scale 1:1	Document type:	Project nr:	Page	5
Original			Replaced by						MFS

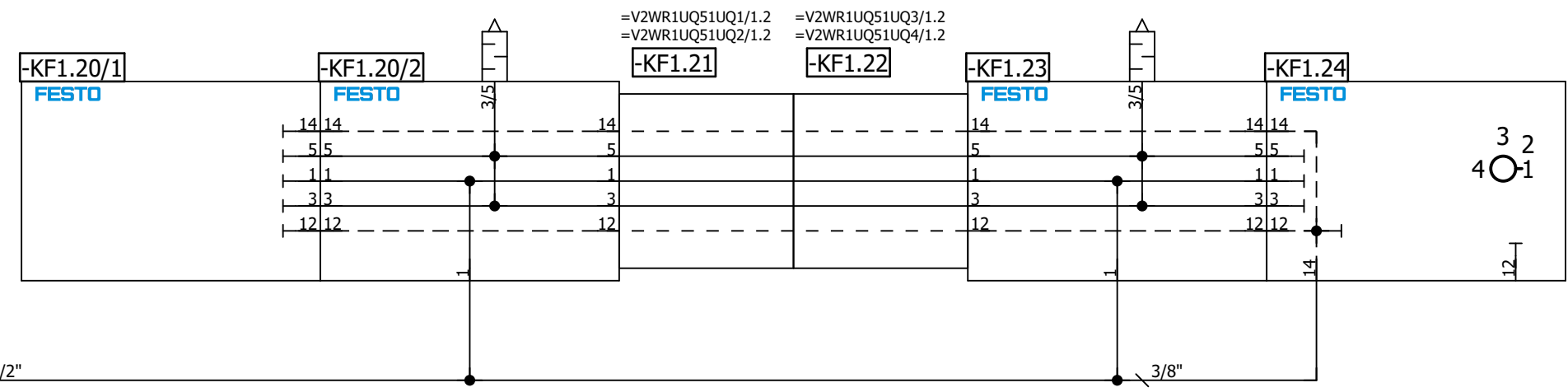
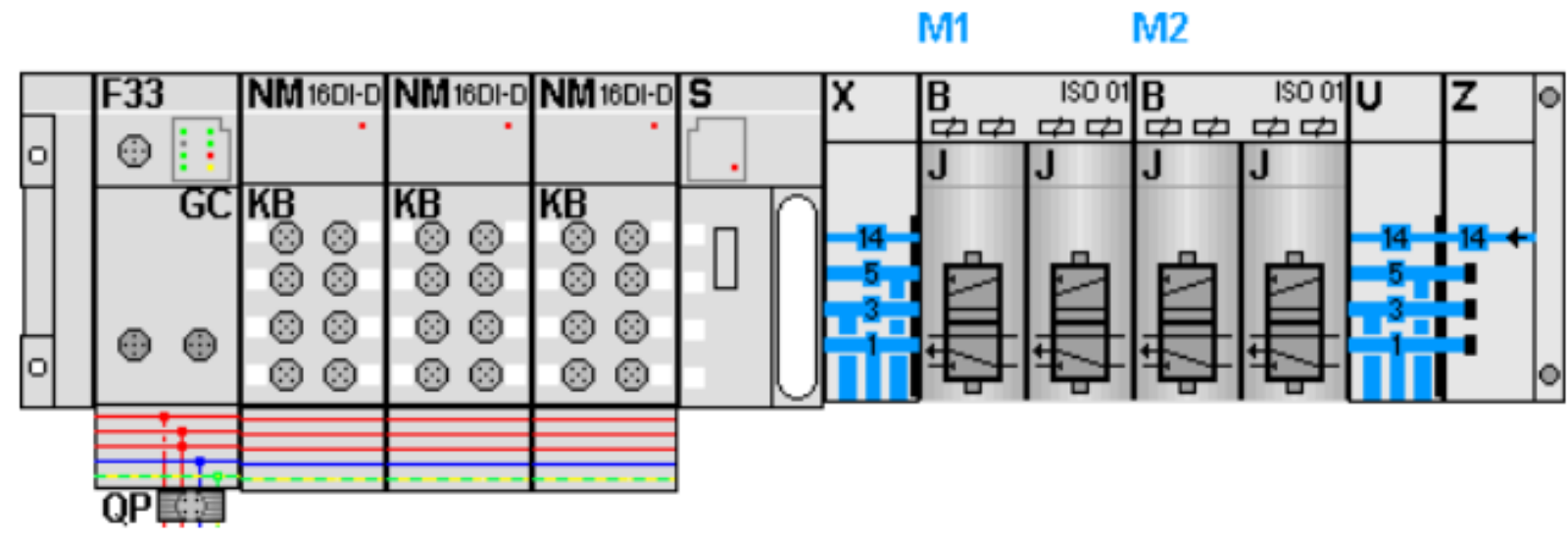

Date		1/4/2023	Volvo Trucks North America		Valiant TMS	AIR SUPPLY	Drawing name:		= V2WR1UQ51KF1			
Ed.		MKLEPADLO	P6700 Side Skin Roof Outer - Cell 2V08				=2V08&MFS-PNEU		+ V2WR1UQ51			
Appr.			Replacement of		Scale 1:1	Document type:		MFS	Project nr:	22-16147	Page	11
Original			Replaced by			MFS					112	



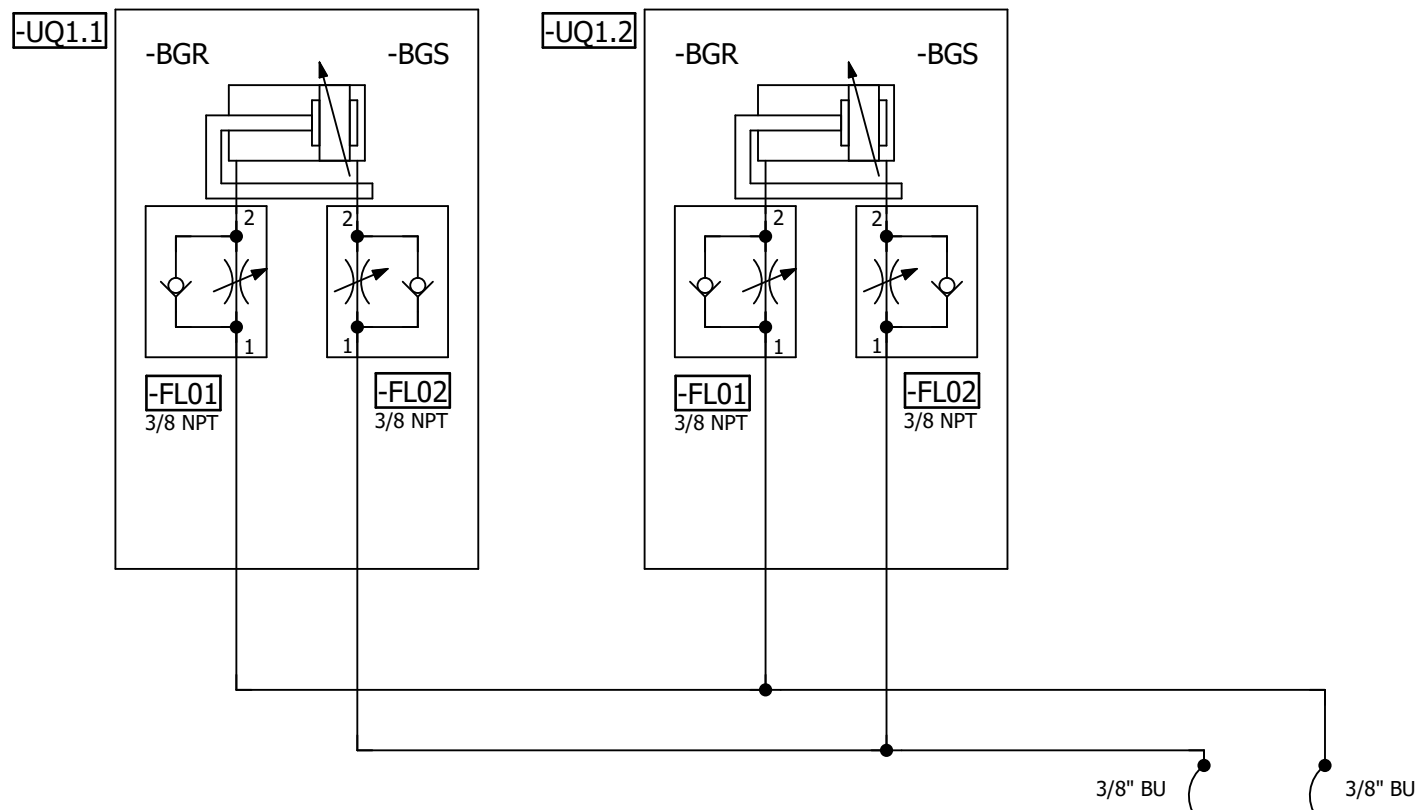

=V2WR1UQ51KF1

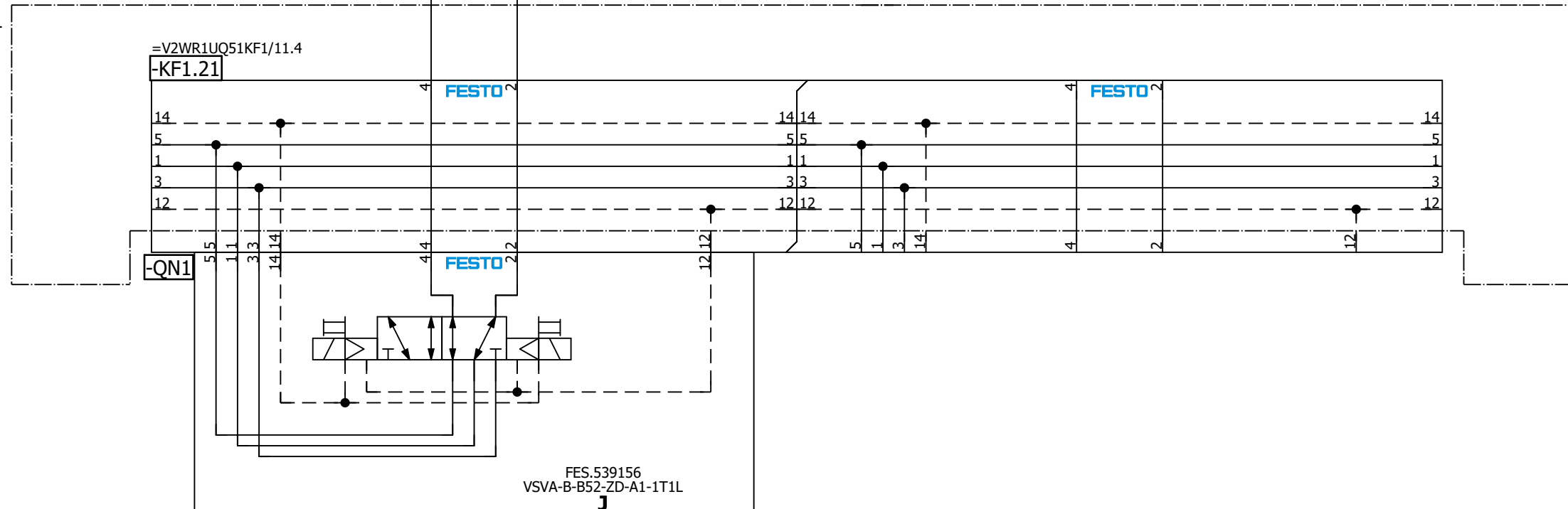

=V2WR1UQ51  
-UQ1-QN1.1  
Shot Pins 1  
(RST)

=V2WR1UQ51  
-UQ1-QN1.2  
Shot Pins 1  
(SET)

=V2WR1UQ51KF1/11

=V2WR1UQ51UQ2/1

Date		1/4/2023	Volvo Trucks North America		Valiant TMS	Shot Pins 1	Drawing name:		= V2WR1UQ51UQ1
Ed.		MKLEPADLO	P6700 Side Skin Roof Outer - Cell 2V08				=2V08&MFS-PNEU		+ V2WR1UQ51
Appr			Replacement of		Scale 1:1		Document type:		MFS
Original			Replaced by				Project nr:		22-16147
Modification	Date	Name	Original				Page		1
									112



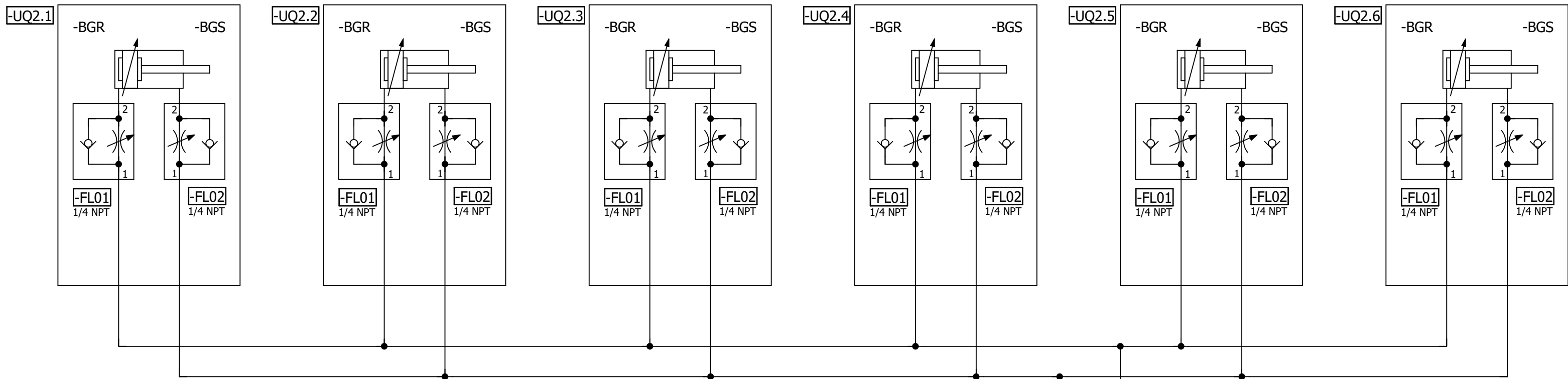

=V2WR1UQ51KF1

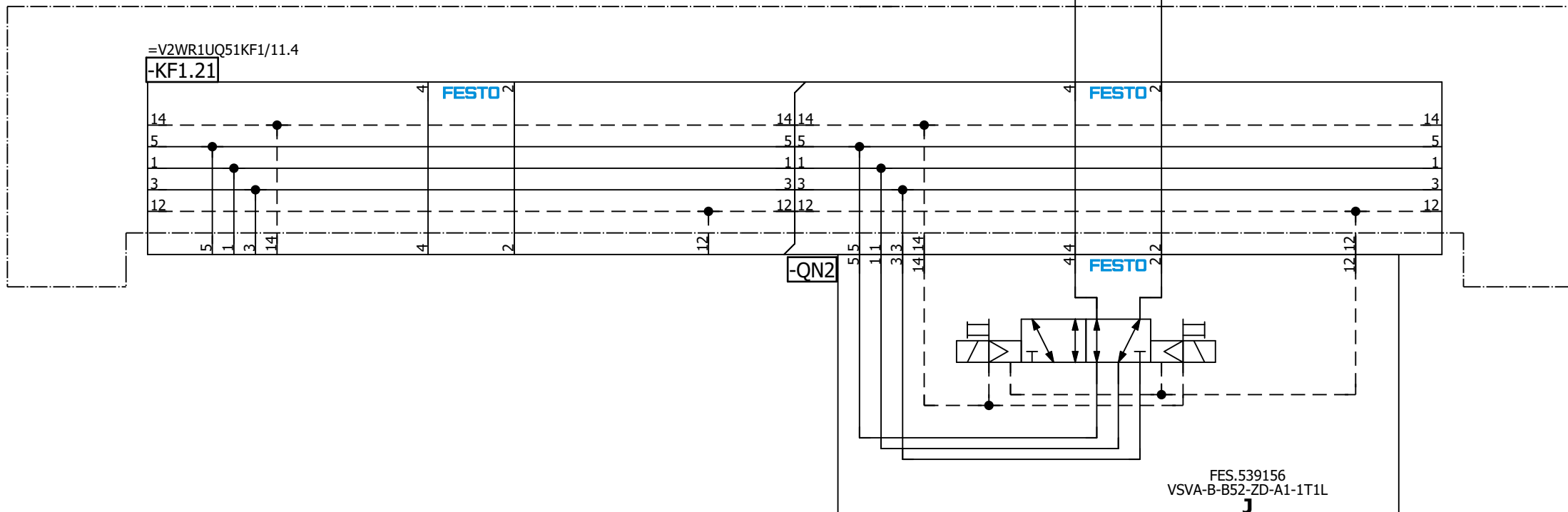

=V2WR1UQ51  
-UQ2-QN2.1  
Clamps 2  
(RST)

=V2WR1UQ51  
-UQ2-QN2.2  
Clamps 2  
(SET)

=V2WR1UQ51UQ3/1

=V2WR1UQ51UQ1/1			Date	1/4/2023	Volvo Trucks North America	Valiant TMS	Clamps 2	Drawing name:	= V2WR1UQ51UQ2	Page 1
			Ed.	MKLEPADLO		Scale 1:1	Drawing type:	=2V08&MFS-PNEU	Project nr: 22-16147	
Modification	Date	Name	Appr.				Replacement of	Replaced by		MFS

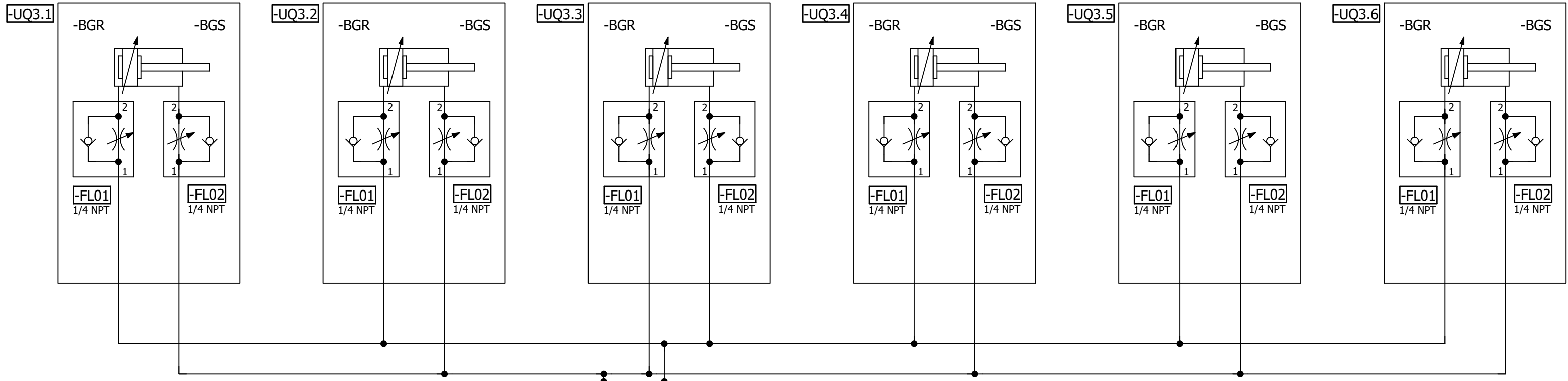

3/8" BU 3/8" BU

=V2WR1UQ51KF1

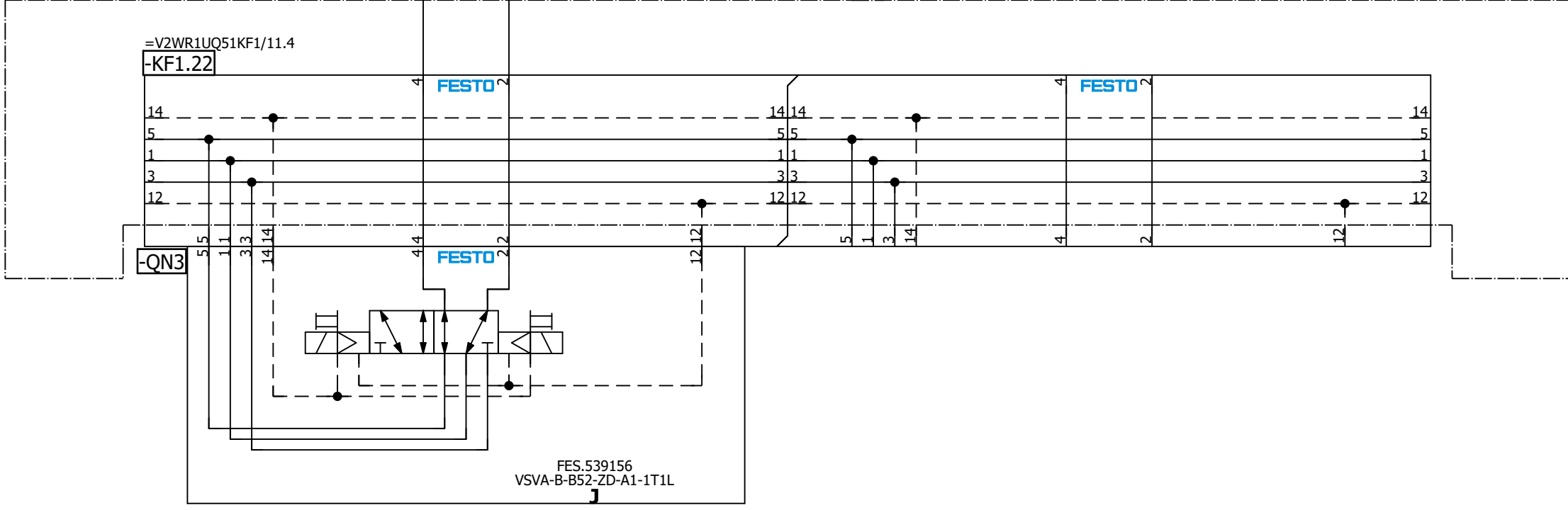

=V2WR1UQ51  
-UQ3-QN3.1  
Clamps 3  
(RST)

=V2WR1UQ51  
-UQ3-QN3.2  
Clamps 3  
(SET)

=V2WR1UQ51UQ2/1

=V2WR1UQ51UQ4/1

Date		1/4/2023		Volvo Trucks North America		Valiant TMS		Clamps 3		Drawing name:		= V2WR1UQ51UQ3	
Ed.		MKLEPADLO		P6700 Side Skin Roof Outer - Cell 2V08		Scale 1:1				Document type:		+ V2WR1UQ51	
Appr				Replacement of		Replaced by				Project nr:		Page 1	
Original										MFS		22-16147 112	

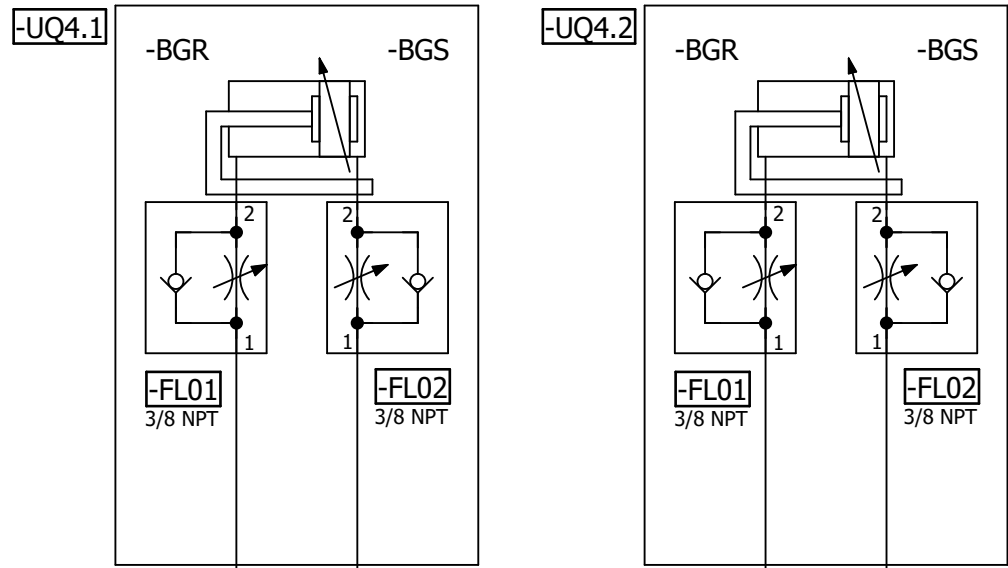

=V2WR1UQ51KF1

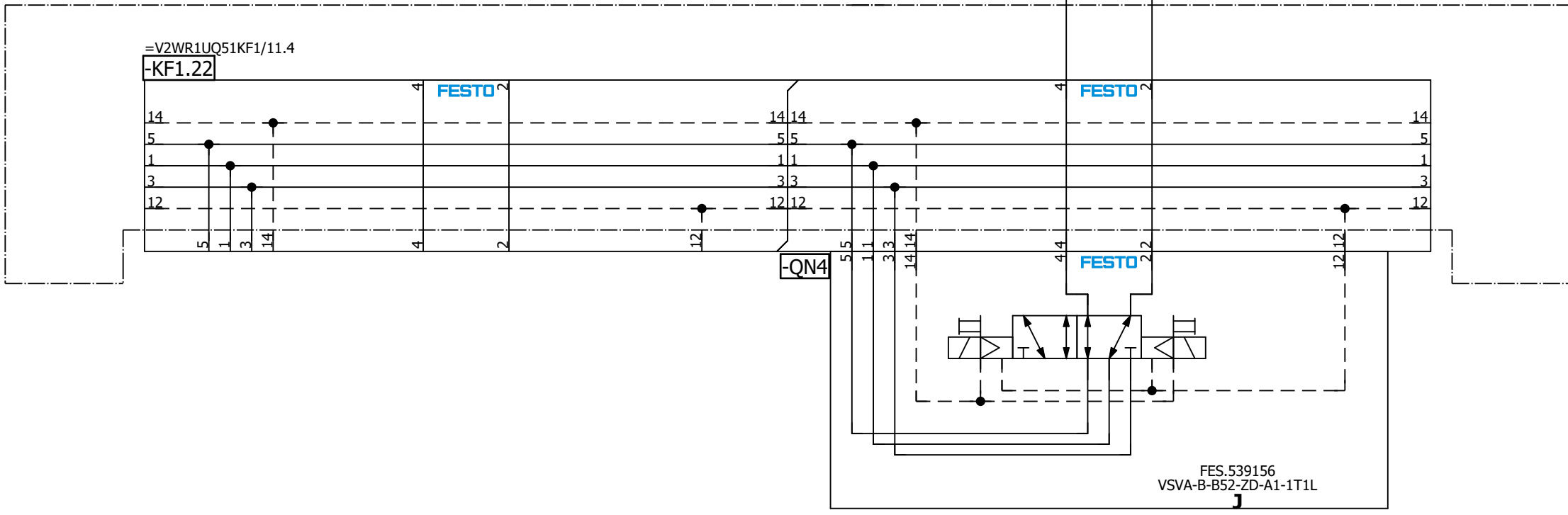

=V2WR1UQ51  
-UQ4-QN4.1  
Shot Pins 4  
(RST)

=V2WR1UQ51  
-UQ4-QN4.2  
Shot Pins 4  
(SET)

=V2WR1UQ52KF1+.WR1UQ52/5

=V2WR1UQ51UQ3/1			Date	1/4/2023	Volvo Trucks North America	Valiant TMS	Shot Pins 4	Drawing name:	= V2WR1UQ51UQ4
			Ed.	MKLEPADLO		Scale 1:1		Drawing type:	= 2V08&MFS-PNEU
			Appr					Document type:	MFS
Modification	Date	Name	Original		Replacement of	Replaced by			Page
									1
									112

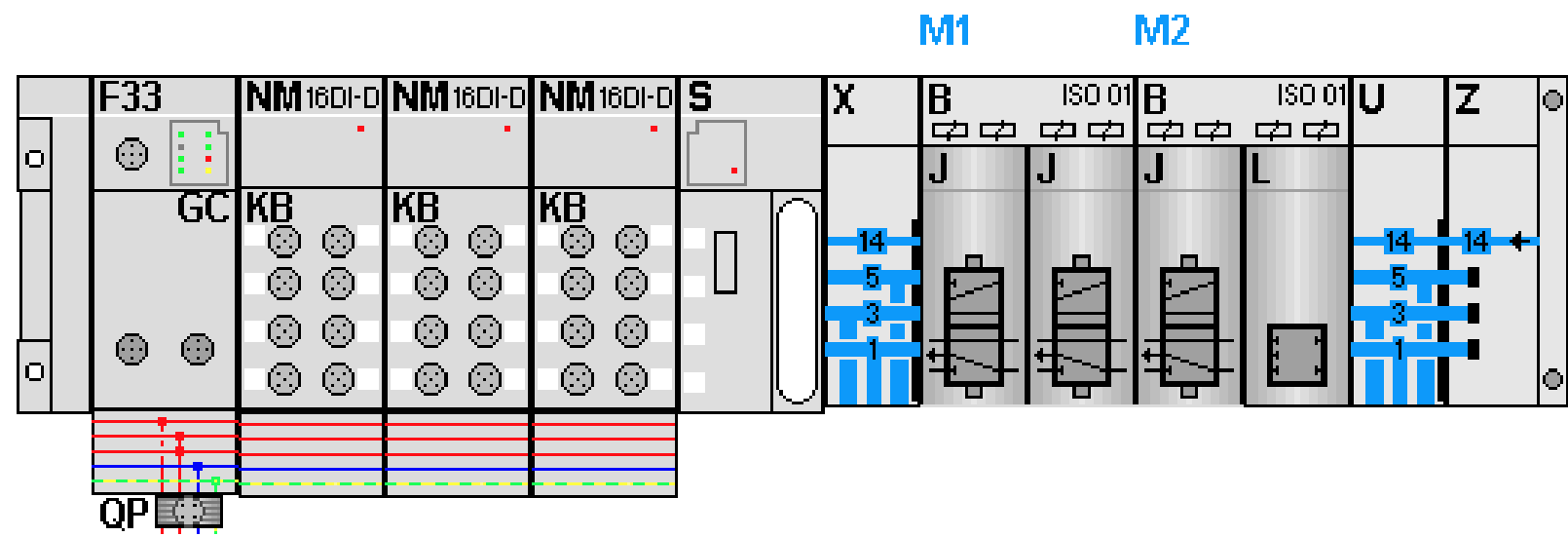

KF1.0

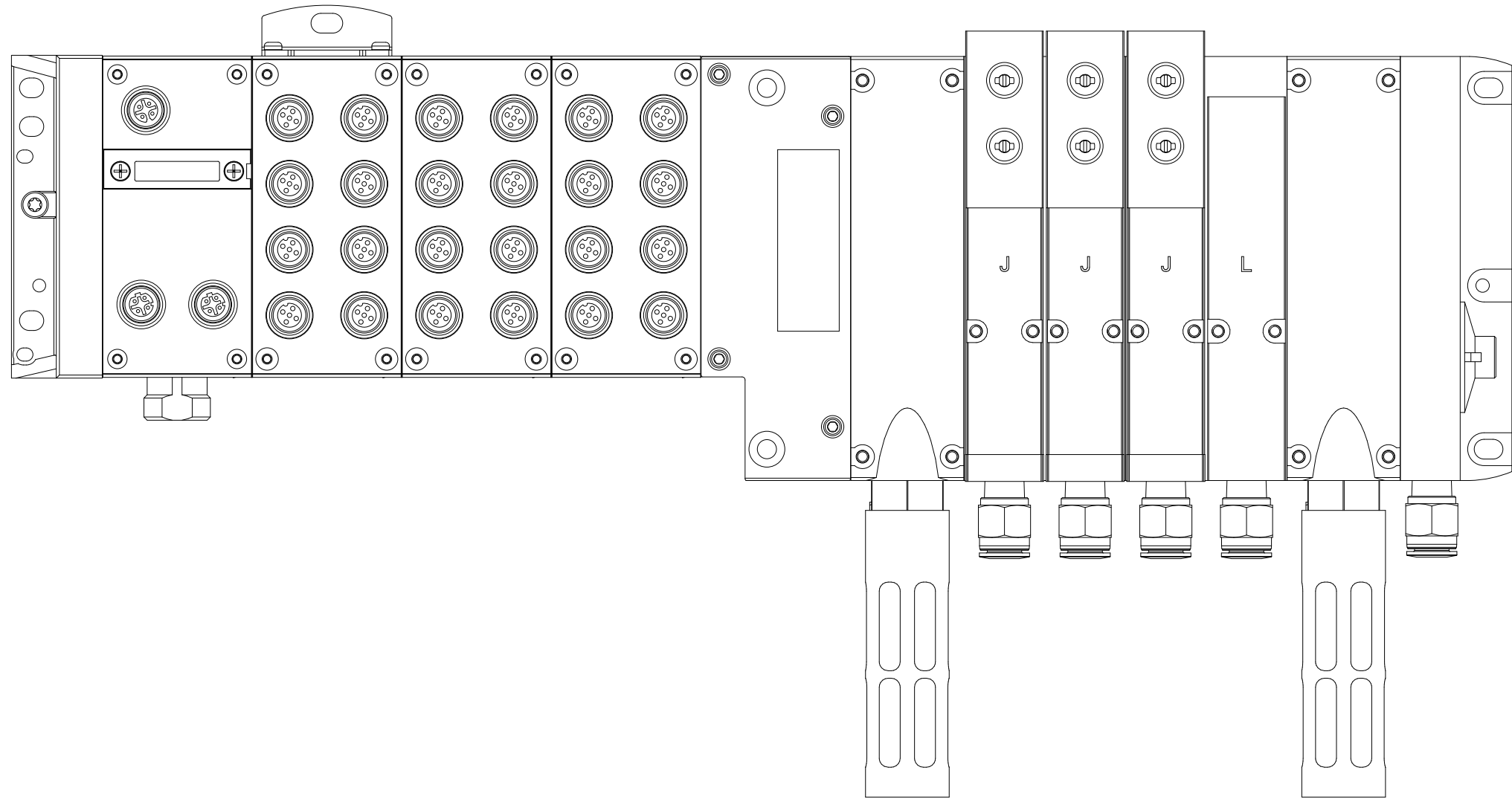

=V2WR1UQ51UQ4+.WR1UQ51/1

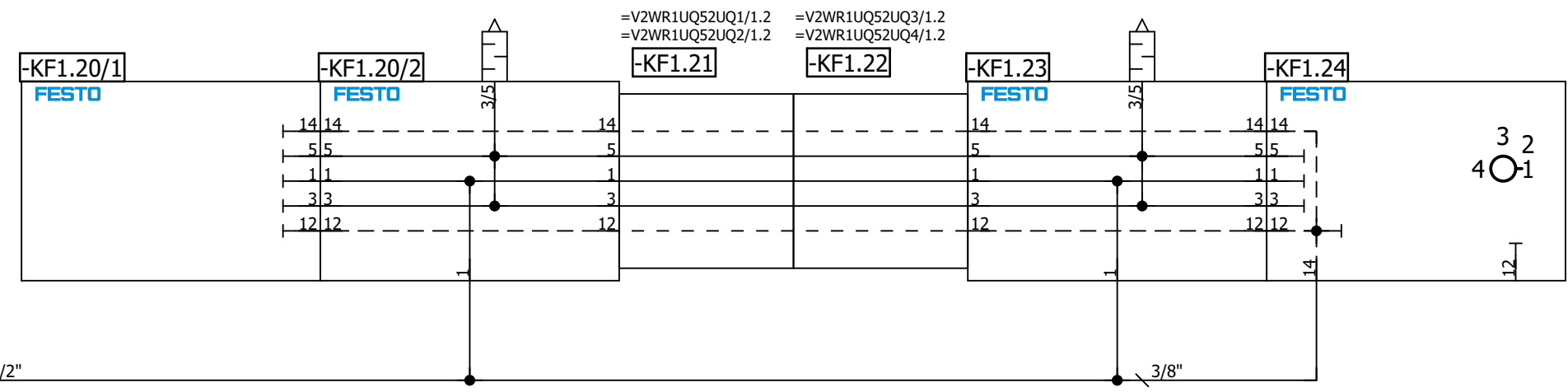
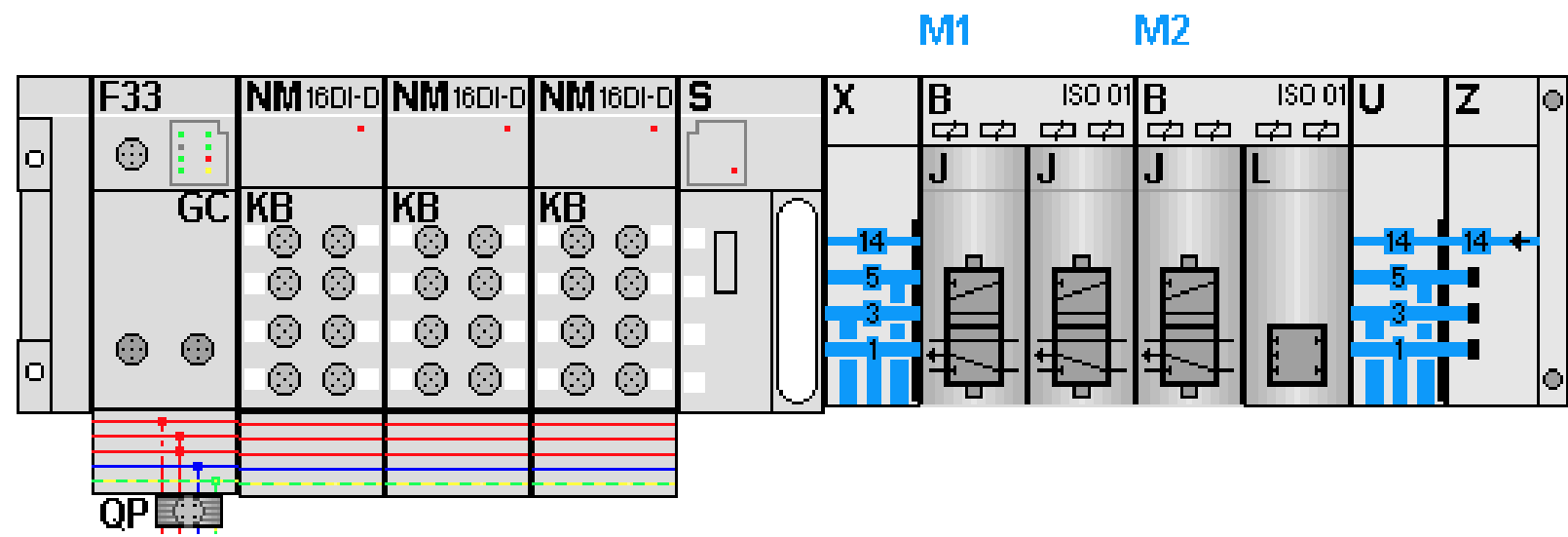

=V2WR1+KH1/1.6 / P1 → 1/2"

5

=V2WR1UQ52UQ1/1



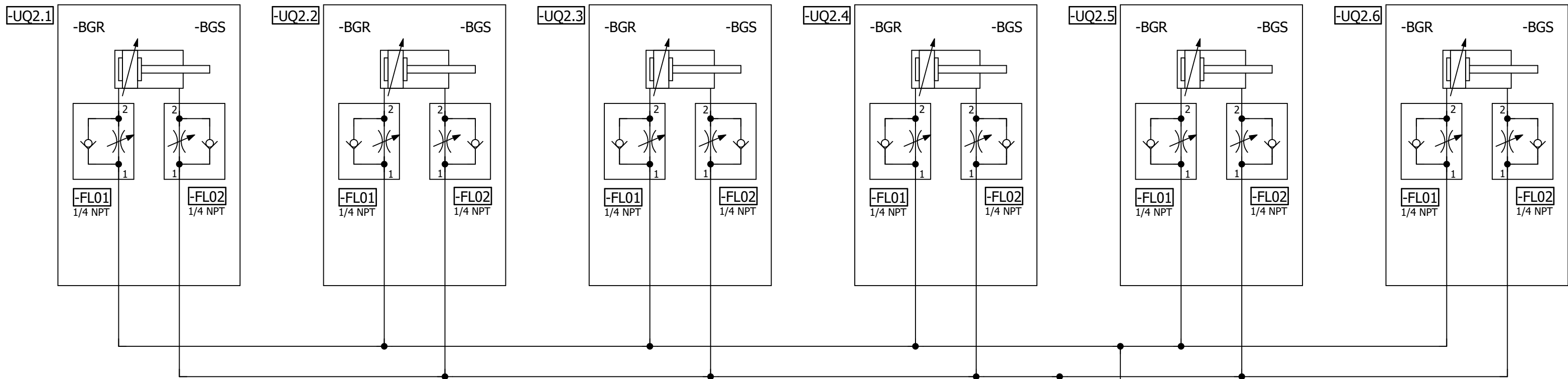

=V2WR1UQ52KF1

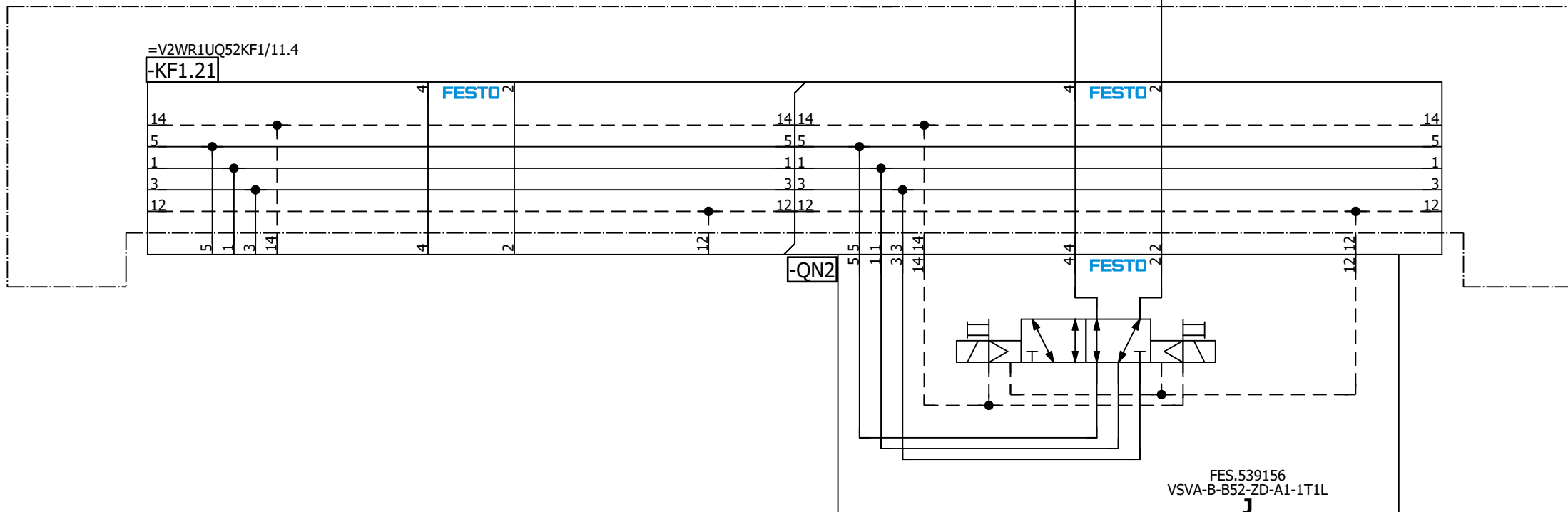

=V2WR1UQ52  
-UQ2-QN2.1  
Clamps 2  
(RST)

=V2WR1UQ52  
-UQ2-QN2.2  
Clamps 2  
(SET)

=V2WR1UQ52UQ3/1

=V2WR1UQ52UQ1/1			Date	1/4/2023	Volvo Trucks North America	Valiant TMS	Clamps 2	Drawing name:	= V2WR1UQ52UQ2	
			Ed.	MKLEPADLO		Scale 1:1		Drawing name:	= 2V08&MFS-PNEU	
			Appr.					Replacement of	Replaced by	Document type:
Modification	Date	Name	Original					Project nr:	22-16147	
									Page	1
										112



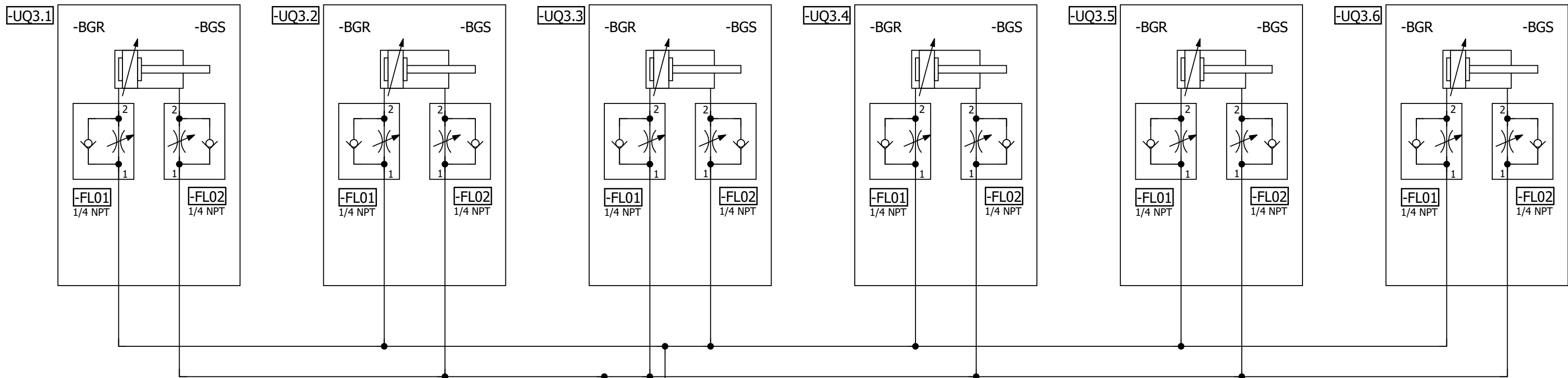

3/8" BU 3/8" BU

=V2WR1UQ52KF1

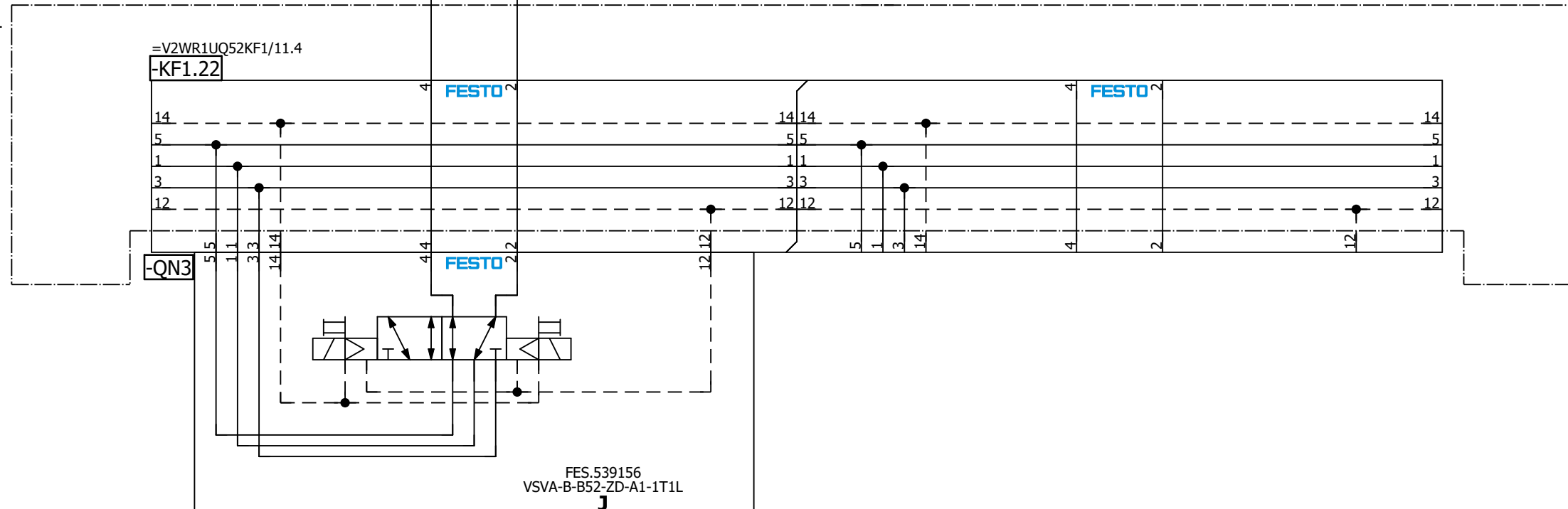

=V2WR1UQ52  
-UQ3-QN3.1  
Clamps 3  
(RST)

=V2WR1UQ52  
-UQ3-QN3.2  
Clamps 3  
(SET)

=V2WR1UQ52UQ2/1 =V2WR1UQ52UQ4/1

Date		1/4/2023	Volvo Trucks North America		Valiant TMS		Clamps 3		Drawing name:		= V2WR1UQ52UQ3	
Ed.		MKLEPADLO	P6700 Side Skin Roof Outer - Cell 2V08		Scale 1:1				Document type:		+ V2WR1UQ52	
Appr.			Replacement of		Replaced by				Project nr:		Page 1	
Original									MFS		22-16147 112	

=V2WR1UQ52KF1

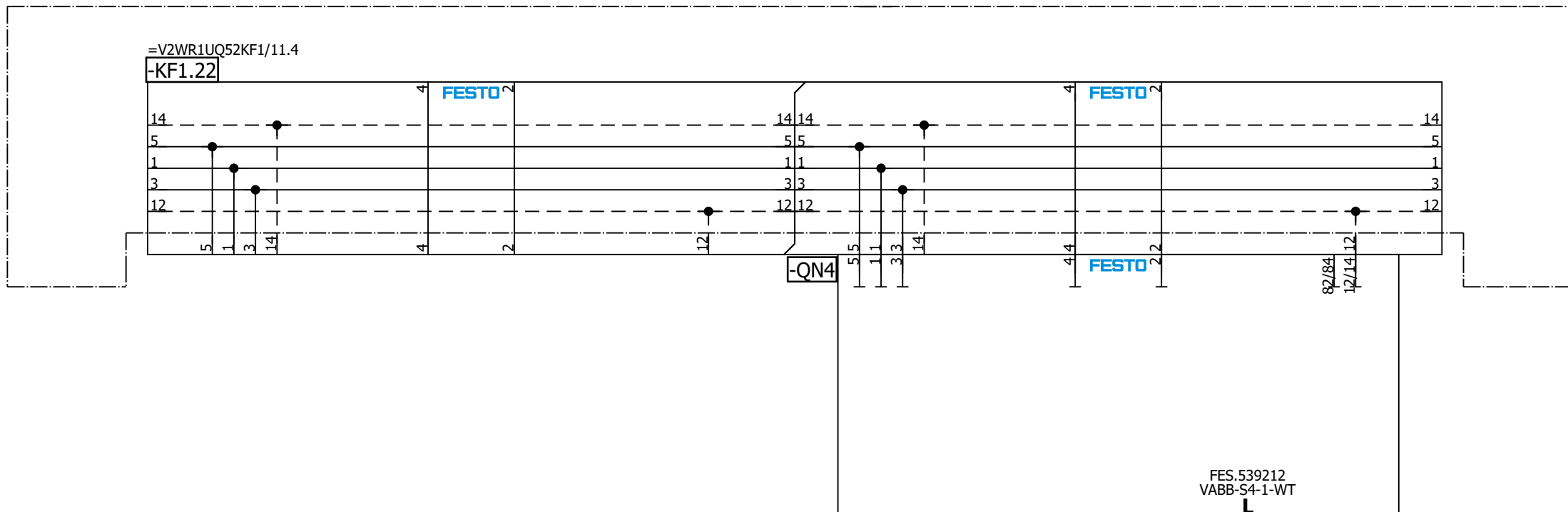

=V2WR1UQ52UQ3/1

&MPB+KH0/1

Date		1/4/2023		Volvo Trucks North America		Valiant TMS		Spare		Drawing name:		= V2WR1UQ52UQ4	
Ed.		MKLEPADLO		P6700 Side Skin Roof Outer - Cell 2V08		Scale 1:1				Document type:		= 2V08&MFS-PNEU	
Appr.				Replacement of		Replaced by				Project nr:		+ V2WR1UQ52	
Modification	Date	Name	Original							MFS		22-16147	
											Page	1	
												112	

# Parts list

Device tag	Quantity	Designation	Type number	Supplier	Part number
=KH0-A1	1	On-off valve	MS12-EM-G-S	FES	FES.535031
=KH0-A1	1	Filter regulator	MS12N-LFR-AQW-D7-E-U-M-AS-LD	FES	FES.535025
=KH0-A1	1	Branching module	MS12-FRM-G	FES	FES.541681
=KH0-A1	1	Mounting bracket	MS12-WP	FES	FES.537133
=KH0-A1	1	Pressure sensor	SPAN-P10R-G18M-PN-PN-L1	FES	FES.8035544
=KH0-A1	1	Connecting cable	NEBS-L1G4-K-5-LE4	FES	FES.572577
=KH0-A1	1	Reducing nipple	NPFC-R-G14-G18-MF	FES	FES.8030308



# Parts list

F01\_001

Device tag	Quantity	Designation	Type number	Supplier	Part number
=V1AR11UQ41KF1-KF1.0	1	Valve Manifold	51E-F33GCQPNMKBNMKBNMKB-D-UL1+GS2GZBA & 32P-TJQ-R-MBHBH-4J	FES	FES.51E-F33GCQPNMKBNMKBNMKB-D-UL1+GS2GZBA & 32P-TJQ-R-MBHBH-4J
=V1AR11UQ41KF1-KF1.21	0	Subbase	VMPA2-FB-AP-2-1	FES	FES.538000
=V1AR11UQ41KF1-KF1.22	0	Subbase	VMPA2-FB-AP-2-1	FES	FES.538000
=V1AR11UQ41UQ1-QN1	0	Solenoid valve	VMPA2-M1H-J-PI	FES	FES.537953
=V1AR11UQ41UQ1-UQ1.1-FL01	1	One-way flow control valve	GRLA-1/8-QB-1/4-U	FES	FES.534658
=V1AR11UQ41UQ1-UQ1.1-FL02	1	One-way flow control valve	GRLA-1/8-QB-1/4-U	FES	FES.534658
=V1AR11UQ41UQ1-UQ1.2-FL01	1	One-way flow control valve	GRLA-1/8-QB-1/4-U	FES	FES.534658
=V1AR11UQ41UQ1-UQ1.2-FL02	1	One-way flow control valve	GRLA-1/8-QB-1/4-U	FES	FES.534658
=V1AR11UQ41UQ1-UQ1.3-FL01	1	One-way flow control valve	GRLA-1/8-QB-1/4-U	FES	FES.534658
=V1AR11UQ41UQ1-UQ1.3-FL02	1	One-way flow control valve	GRLA-1/8-QB-1/4-U	FES	FES.534658
=V1AR11UQ41UQ1-UQ1.4-FL01	1	One-way flow control valve	GRLA-1/8-QB-1/4-U	FES	FES.534658
=V1AR11UQ41UQ1-UQ1.4-FL02	1	One-way flow control valve	GRLA-1/8-QB-1/4-U	FES	FES.534658
=V1AR11UQ41UQ2-QN2	0	Solenoid valve	VMPA2-M1H-J-PI	FES	FES.537953
=V1AR11UQ41UQ2-UQ2.1-FL01	1	One-way flow control valve	GRLA-1/8-QB-1/4-U	FES	FES.534658
=V1AR11UQ41UQ2-UQ2.1-FL02	1	One-way flow control valve	GRLA-1/8-QB-1/4-U	FES	FES.534658
=V1AR11UQ41UQ3-QN3	0	Solenoid valve	VMPA2-M1H-J-PI	FES	FES.537953
=V1AR11UQ41UQ3-UQ3.1-FL01	1	One-way flow control valve	GRLA-1/8-QB-1/4-U	FES	FES.534658
=V1AR11UQ41UQ3-UQ3.1-FL02	1	One-way flow control valve	GRLA-1/8-QB-1/4-U	FES	FES.534658
=V1AR11UQ41UQ4-QN4	0	Solenoid valve	VMPA2-M1H-J-PI	FES	FES.537953
=V1AR11UQ41UQ4-UQ4.1-FL01	1	One-way flow control valve	GRLA-1/8-QB-1/4-U	FES	FES.534658
=V1AR11UQ41UQ4-UQ4.1-FL02	1	One-way flow control valve	GRLA-1/8-QB-1/4-U	FES	FES.534658
=V1AR11UQ41UQ4-UQ4.2-FL01	1	One-way flow control valve	GRLA-1/8-QB-1/4-U	FES	FES.534658
=V1AR11UQ41UQ4-UQ4.2-FL02	1	One-way flow control valve	GRLA-1/8-QB-1/4-U	FES	FES.534658
=V1AR11UQ41UQ4-UQ4.3-FL01	1	One-way flow control valve	GRLA-1/8-QB-1/4-U	FES	FES.534658
=V1AR11UQ41UQ4-UQ4.3-FL02	1	One-way flow control valve	GRLA-1/8-QB-1/4-U	FES	FES.534658
=V1AR11UQ41UQ4-UQ4.4-FL01	1	One-way flow control valve	GRLA-1/8-QB-1/4-U	FES	FES.534658
=V1AR11UQ41UQ4-UQ4.4-FL02	1	One-way flow control valve	GRLA-1/8-QB-1/4-U	FES	FES.534658

+KH1/1

+ .AR11UQ42/1

Date	1/4/2023	Volvo Trucks North America	Valiant TMS	Parts list :	Drawing name:	=		
Ed.	MKLEPADLO	P6700 Side Skin Roof Outer - Cell 2V08		FES.51E-F33GCQPNMKBNMKBNMKB-D-UL1+GS2GZBA & 32P-TJQ-R-MBHBH-4J - FES.534658	F2V08&MFS-PNEU	+ V1AR11UQ41		
Appr				Scale 1:1	& 32P-TJQ-R-MBHBH-4J - FES.534658	Document type:	Project nr:	Page 1
Modification	Date	Name	Original	Replacement of	Replaced by	MPB	22-16147	112

# Parts list

F01\_001

Device tag	Quantity	Designation	Type number	Supplier	Part number
=V1AR11UQ42KF1-KF1.0	1	Valve manifold	51E-F33GCQPNMKBNMKBNMKB-D-UL1+GS2GZBA & 32P-TJQ-R-MBHBHBH-6J	FES	FES.51E-F33GCQPNMKBNMKBNMKB-D-UL1+GS2GZBA & 32P-TJQ-R-MBHBHBH-6J
=V1AR11UQ42KF1-KF1.21	0	Subbase	VMPA2-FB-AP-2-1	FES	FES.538000
=V1AR11UQ42KF1-KF1.22	0	Subbase	VMPA2-FB-AP-2-1	FES	FES.538000
=V1AR11UQ42KF1-KF1.23	0	Subbase	VMPA2-FB-AP-2-1	FES	FES.538000
=V1AR11UQ42UQ1-QN1	0	Solenoid valve	VMPA2-M1H-J-PI	FES	FES.537953
=V1AR11UQ42UQ1-UQ1.1-FL01	1	One-way flow control valve	GRLA-1/4-QB-1/4-U	FES	FES.534661
=V1AR11UQ42UQ1-UQ1.1-FL02	1	One-way flow control valve	GRLA-1/4-QB-1/4-U	FES	FES.534661
=V1AR11UQ42UQ1-UQ1.2-FL01	1	One-way flow control valve	GRLA-1/4-QB-1/4-U	FES	FES.534661
=V1AR11UQ42UQ1-UQ1.2-FL02	1	One-way flow control valve	GRLA-1/4-QB-1/4-U	FES	FES.534661
=V1AR11UQ42UQ1-UQ1.3-FL01	1	One-way flow control valve	GRLA-1/4-QB-1/4-U	FES	FES.534661
=V1AR11UQ42UQ1-UQ1.3-FL02	1	One-way flow control valve	GRLA-1/4-QB-1/4-U	FES	FES.534661
=V1AR11UQ42UQ1-UQ1.4-FL01	1	One-way flow control valve	GRLA-1/4-QB-1/4-U	FES	FES.534661
=V1AR11UQ42UQ1-UQ1.4-FL02	1	One-way flow control valve	GRLA-1/4-QB-1/4-U	FES	FES.534661
=V1AR11UQ42UQ2-QN2	0	Solenoid valve	VMPA2-M1H-J-PI	FES	FES.537953
=V1AR11UQ42UQ2-UQ2.1-FL01	1	One-way flow control valve	GRLA-1/4-QB-1/4-U	FES	FES.534661
=V1AR11UQ42UQ2-UQ2.1-FL02	1	One-way flow control valve	GRLA-1/4-QB-1/4-U	FES	FES.534661
=V1AR11UQ42UQ2-UQ2.2-FL01	1	One-way flow control valve	GRLA-1/4-QB-1/4-U	FES	FES.534661
=V1AR11UQ42UQ2-UQ2.2-FL02	1	One-way flow control valve	GRLA-1/4-QB-1/4-U	FES	FES.534661
=V1AR11UQ42UQ2-UQ2.3-FL01	1	One-way flow control valve	GRLA-1/4-QB-1/4-U	FES	FES.534661
=V1AR11UQ42UQ2-UQ2.3-FL02	1	One-way flow control valve	GRLA-1/4-QB-1/4-U	FES	FES.534661
=V1AR11UQ42UQ2-UQ2.4-FL01	1	One-way flow control valve	GRLA-1/4-QB-1/4-U	FES	FES.534661
=V1AR11UQ42UQ2-UQ2.4-FL02	1	One-way flow control valve	GRLA-1/4-QB-1/4-U	FES	FES.534661
=V1AR11UQ42UQ2-UQ2.5-FL01	1	One-way flow control valve	GRLA-1/4-QB-1/4-U	FES	FES.534661
=V1AR11UQ42UQ2-UQ2.5-FL02	1	One-way flow control valve	GRLA-1/4-QB-1/4-U	FES	FES.534661
=V1AR11UQ42UQ2-UQ2.6-FL01	1	One-way flow control valve	GRLA-1/4-QB-1/4-U	FES	FES.534661
=V1AR11UQ42UQ2-UQ2.6-FL02	1	One-way flow control valve	GRLA-1/4-QB-1/4-U	FES	FES.534661
=V1AR11UQ42UQ3-QN3	0	Solenoid valve	VMPA2-M1H-J-PI	FES	FES.537953
=V1AR11UQ42UQ3-UQ3.1-FL01	1	One-way flow control valve	GRLA-1/8-QB-1/4-U	FES	FES.534658
=V1AR11UQ42UQ3-UQ3.1-FL02	1	One-way flow control valve	GRLA-1/8-QB-1/4-U	FES	FES.534658
=V1AR11UQ42UQ3-UQ3.2-FL01	1	One-way flow control valve	GRLA-1/8-QB-1/4-U	FES	FES.534658
=V1AR11UQ42UQ3-UQ3.2-FL02	1	One-way flow control valve	GRLA-1/8-QB-1/4-U	FES	FES.534658
=V1AR11UQ42UQ4-QN4	0	Solenoid valve	VMPA2-M1H-J-PI	FES	FES.537953
=V1AR11UQ42UQ5-QN5	0	Solenoid valve	VMPA2-M1H-J-PI	FES	FES.537953
=V1AR11UQ42UQ6-QN6	0	Solenoid valve	VMPA2-M1H-J-PI	FES	FES.537953

+ .AR11UQ41/1

+ .AR11UQ43/1

Date	1/4/2023	Volvo Trucks North America	Valiant TMS	Parts list :	Drawing name:	=	
Ed.	MKLEPADLO	P6700 Side Skin Roof Outer - Cell 2V08	Scale 1:1	FES.51E-F33GCQPNMKBNMKBNMKB-D-UL1+GS2GZBA & 32P-TJQ-R-MBHBHBH-6J - FES.537953	F2V08&MFS-PNEU	+ V1AR11UQ42	
Appr							Document type:
Modification	Date	Name	Original	Replaced by	MPB	22-16147	1
							112

# Parts list

F01\_001

Device tag	Quantity	Designation	Type number	Supplier	Part number
=V1AR11UQ43KF1-KF1.0	1	Valve manifold	51E-F33GCQPNMKBNMKBNMKB-D-UL1+GS2GZBA & 32P-TJQ-R-MBHBHBH-6J	FES	FES.51E-F33GCQPNMKBNMKBNMKB-D-UL1+GS2GZBA & 32P-TJQ-R-MBHBHBH-6J
=V1AR11UQ43KF1-KF1.21	0	Subbase	VMPA2-FB-AP-2-1	FES	FES.538000
=V1AR11UQ43KF1-KF1.22	0	Subbase	VMPA2-FB-AP-2-1	FES	FES.538000
=V1AR11UQ43KF1-KF1.23	0	Subbase	VMPA2-FB-AP-2-1	FES	FES.538000
=V1AR11UQ43UQ1-QN1	0	Solenoid valve	VMPA2-M1H-J-PI	FES	FES.537953
=V1AR11UQ43UQ2-QN2	0	Solenoid valve	VMPA2-M1H-J-PI	FES	FES.537953
=V1AR11UQ43UQ3-QN3	0	Solenoid valve	VMPA2-M1H-J-PI	FES	FES.537953
=V1AR11UQ43UQ3-UQ3.1-FL01	1	One-way flow control valve	GRLA-1/4-QB-1/4-U	FES	FES.534661
=V1AR11UQ43UQ3-UQ3.1-FL02	1	One-way flow control valve	GRLA-1/4-QB-1/4-U	FES	FES.534661
=V1AR11UQ43UQ3-UQ3.2-FL01	1	One-way flow control valve	GRLA-1/4-QB-1/4-U	FES	FES.534661
=V1AR11UQ43UQ3-UQ3.2-FL02	1	One-way flow control valve	GRLA-1/4-QB-1/4-U	FES	FES.534661
=V1AR11UQ43UQ4-QN4	0	Solenoid valve	VMPA2-M1H-J-PI	FES	FES.537953
=V1AR11UQ43UQ4-UQ4.1-FL01	1	One-way flow control valve	GRLA-1/4-QB-1/4-U	FES	FES.534661
=V1AR11UQ43UQ4-UQ4.1-FL02	1	One-way flow control valve	GRLA-1/4-QB-1/4-U	FES	FES.534661
=V1AR11UQ43UQ4-UQ4.2-FL01	1	One-way flow control valve	GRLA-1/4-QB-1/4-U	FES	FES.534661
=V1AR11UQ43UQ4-UQ4.2-FL02	1	One-way flow control valve	GRLA-1/4-QB-1/4-U	FES	FES.534661
=V1AR11UQ43UQ5-QN5	0	Solenoid valve	VMPA2-M1H-J-PI	FES	FES.537953
=V1AR11UQ43UQ5-UQ5.1-FL01	1	One-way flow control valve	GRLA-1/4-QB-1/4-U	FES	FES.534661
=V1AR11UQ43UQ5-UQ5.1-FL02	1	One-way flow control valve	GRLA-1/4-QB-1/4-U	FES	FES.534661
=V1AR11UQ43UQ5-UQ5.2-FL01	1	One-way flow control valve	GRLA-1/4-QB-1/4-U	FES	FES.534661
=V1AR11UQ43UQ5-UQ5.2-FL02	1	One-way flow control valve	GRLA-1/4-QB-1/4-U	FES	FES.534661
=V1AR11UQ43UQ6-QN6	0	Solenoid valve	VMPA2-M1H-J-PI	FES	FES.537953

+ .AR11UQ42/1

+ .AR201UQ41/1

Date		1/4/2023		Volvo Trucks North America		Valiant TMS		Parts list :		Drawing name:		=	
Ed.		MKLEPADLO		P6700 Side Skin Roof Outer - Cell 2V08		Scale 1:1		FES.51E-F33GCQPNMKBNMKBNMKB-D-UL1+GS2GZBA & 32P-TJQ-R-MBHBHBH-6J - FES.537953		F2V08&MFS-PNEU		+ V1AR11UQ43	
Appr										Document type:		Project nr:	
Modification	Date	Name	Original	Replacement of	Replaced by			MPB		22-16147		1	
												112	







# Parts list

F01\_001

Device tag	Quantity	Designation	Type number	Supplier	Part number
=V1AR201UQ42KF1-KF1.0	1	Valve Manifold	51E-F33GCQPNMKBNMKBNMKB-D-UL1+GS2GZBA & 32P-TJQ-R-MBHBH-4J	FES	FES.51E-F33GCQPNMKBNMKBNMKB-D-UL1+GS2GZBA & 32P-TJQ-R-MBHBH-4J
=V1AR201UQ42KF1-KF1.21	0	Subbase	VMPA2-FB-AP-2-1	FES	FES.538000
=V1AR201UQ42KF1-KF1.22	0	Subbase	VMPA2-FB-AP-2-1	FES	FES.538000
=V1AR201UQ42UQ1-QN1	0	Solenoid valve	VMPA2-M1H-J-PI	FES	FES.537953
=V1AR201UQ42UQ1-UQ1.1-FL01	1	One-way flow control valve	GRLA-1/4-QB-1/4-U	FES	FES.534661
=V1AR201UQ42UQ1-UQ1.1-FL02	1	One-way flow control valve	GRLA-1/4-QB-1/4-U	FES	FES.534661
=V1AR201UQ42UQ1-UQ1.2-FL01	1	One-way flow control valve	GRLA-1/4-QB-1/4-U	FES	FES.534661
=V1AR201UQ42UQ1-UQ1.2-FL02	1	One-way flow control valve	GRLA-1/4-QB-1/4-U	FES	FES.534661
=V1AR201UQ42UQ1-UQ1.3-FL01	1	One-way flow control valve	GRLA-1/4-QB-1/4-U	FES	FES.534661
=V1AR201UQ42UQ1-UQ1.3-FL02	1	One-way flow control valve	GRLA-1/4-QB-1/4-U	FES	FES.534661
=V1AR201UQ42UQ2-QN2	0	Solenoid valve	VMPA2-M1H-J-PI	FES	FES.537953
=V1AR201UQ42UQ2-UQ2.1-FL01	1	One-way flow control valve	GRLA-1/4-QB-1/4-U	FES	FES.534661
=V1AR201UQ42UQ2-UQ2.1-FL02	1	One-way flow control valve	GRLA-1/4-QB-1/4-U	FES	FES.534661
=V1AR201UQ42UQ2-UQ2.2-FL01	1	One-way flow control valve	GRLA-1/4-QB-1/4-U	FES	FES.534661
=V1AR201UQ42UQ2-UQ2.2-FL02	1	One-way flow control valve	GRLA-1/4-QB-1/4-U	FES	FES.534661
=V1AR201UQ42UQ2-UQ2.3-FL01	1	One-way flow control valve	GRLA-1/4-QB-1/4-U	FES	FES.534661
=V1AR201UQ42UQ2-UQ2.3-FL02	1	One-way flow control valve	GRLA-1/4-QB-1/4-U	FES	FES.534661
=V1AR201UQ42UQ3-QN3	0	Solenoid valve	VMPA2-M1H-J-PI	FES	FES.537953
=V1AR201UQ42UQ4-QN4	0	Solenoid valve	VMPA2-M1H-J-PI	FES	FES.537953

+ .AR201UQ41/1

+ .PF1/1

Date	1/4/2023	Volvo Trucks North America	Valiant TMS	Parts list :	Drawing name:	=
Ed.	MKLEPADLO	P6700 Side Skin Roof Outer - Cell 2V08		FES.51E-F33GCQPNMKBNMKBNMKB-D-UL1+GS2GZBA & 32P-TJQ-R-MBHBH-4J - FES.537953	F-2V08&MFS-PNEU	+ V1AR201UQ42
Appr				Scale 1:1	Document type:	Project nr:
Original		Replacement of	Replaced by	& 32P-TJQ-R-MBHBH-4J - FES.537953	MPB	22-16147
Modification	Date	Name				112









# Parts list

F01\_001

Device tag	Quantity	Designation	Type number	Supplier	Part number
=V2LB1KF1-KF1.0	1	Valve manifold	51E-F33GCQPNMKBNMKBNMKBNMKB-S-UL1+GS2GZBA & 45PN-R-Z-LSMX-BU-SASA	FES	FES.51E-F33GCQPNMKBNMKBNMKBNMKB-S-UL1+GS2GZBA & 45PN-R-Z-LSMX-BU-SASA
=V2LB1KF1-KF1.21	0	Manifold subbase	VABV-S4-1HS-N14-2T2		FES.546213
=V2LB1UQ1-QN1	0	Solenoid valve	VSVA-B-B52-ZD-A1-1T1L	FES	FES.539156
=V2LB1UQ1-UQ1.1-FL01	1	One-way flow control valve	GRLA-1/4-QB-3/8-U		FES.534663
=V2LB1UQ1-UQ1.1-FL02	1	One-way flow control valve	GRLA-1/4-QB-3/8-U		FES.534663
=V2LB1UQ1-UQ1.2-FL01	1	One-way flow control valve	GRLA-1/4-QB-3/8-U		FES.534663
=V2LB1UQ1-UQ1.2-FL02	1	One-way flow control valve	GRLA-1/4-QB-3/8-U		FES.534663
=V2LB1UQ1-UQ1.3-FL01	1	One-way flow control valve	GRLA-1/4-QB-3/8-U		FES.534663
=V2LB1UQ1-UQ1.3-FL02	1	One-way flow control valve	GRLA-1/4-QB-3/8-U		FES.534663
=V2LB1UQ2-QN2	0	Solenoid valve	VSVA-B-B52-ZD-A1-1T1L	FES	FES.539156
=V2LB1UQ2-UQ2.1-FL01	1	One-way flow control valve	GRLA-1/4-QB-3/8-U		FES.534663
=V2LB1UQ2-UQ2.1-FL02	1	One-way flow control valve	GRLA-1/4-QB-3/8-U		FES.534663
=V2LB1UQ2-UQ2.2-FL01	1	One-way flow control valve	GRLA-1/4-QB-3/8-U		FES.534663
=V2LB1UQ2-UQ2.2-FL02	1	One-way flow control valve	GRLA-1/4-QB-3/8-U		FES.534663
=V2LB1UQ2-UQ2.3-FL01	1	One-way flow control valve	GRLA-1/4-QB-3/8-U		FES.534663
=V2LB1UQ2-UQ2.3-FL02	1	One-way flow control valve	GRLA-1/4-QB-3/8-U		FES.534663
=V2LB1UQ2-UQ2.4-FL01	1	One-way flow control valve	GRLA-1/4-QB-3/8-U		FES.534663
=V2LB1UQ2-UQ2.4-FL02	1	One-way flow control valve	GRLA-1/4-QB-3/8-U		FES.534663

+V1WR1UQ52/1

+ .WR1UQ51/1

Date	1/4/2023	Volvo Trucks North America	Valiant TMS	Parts list :	Drawing name:	=	
Ed.	MKLEPADLO	P6700 Side Skin Roof Outer - Cell 2V08		FES.51E-F33GCQPNMKBNMKBNMKBNMKB-S-UL1+GS2GZBA & 45PN-R-Z-LSMX-BU-SASA - FES.534663	51E-F33GCQPNMKBNMKBNMKBNMKB-S-UL1+GS2GZBA & 45PN-R-Z-LSMX-BU-SASA - FES.534663	+ V2LB1	
Appr				Scale 1:1	Document type:	Project nr:	Page
Modification	Date	Name	Original	Replaced by	MPB	22-16147	1
							112





# Parts list

F01\_001

Device tag	Quantity	Designation	Type number	Supplier	Part number
=V2WR1UQ52KF1-KF1.0	1	Valve Manifold	51E-F33GCQPNMKBNMKBNMK-B-S-UL1+GS2GZBA & 45PN-R-Z-LSMX-BBU-3JL	FES	FES.51E-F33GCQPNMKBNMKBNMK-B-S-UL1+GS2GZBA & 45PN-R-Z-LSMX-BBU-3JL
=V2WR1UQ52KF1-KF1.21	0	Manifold subbase	VABV-S4-1HS-N14-2T2		FES.546213
=V2WR1UQ52KF1-KF1.22	0	Manifold subbase	VABV-S4-1HS-N14-2T2		FES.546213
=V2WR1UQ52UQ1-QN1	0	Solenoid valve	VSVA-B-B52-ZD-A1-1T1L	FES	FES.539156
=V2WR1UQ52UQ1-UQ1.1-FL01	1	One-way flow control valve	GRLA-1/4-QB-3/8-U		FES.534663
=V2WR1UQ52UQ1-UQ1.1-FL02	1	One-way flow control valve	GRLA-1/4-QB-3/8-U		FES.534663
=V2WR1UQ52UQ1-UQ1.2-FL01	1	One-way flow control valve	GRLA-1/4-QB-3/8-U		FES.534663
=V2WR1UQ52UQ1-UQ1.2-FL02	1	One-way flow control valve	GRLA-1/4-QB-3/8-U		FES.534663
=V2WR1UQ52UQ2-QN2	0	Solenoid valve	VSVA-B-B52-ZD-A1-1T1L	FES	FES.539156
=V2WR1UQ52UQ2-UQ2.1-FL01	1	One-way flow control valve	GRLA-1/4-QB-3/8-U		FES.534663
=V2WR1UQ52UQ2-UQ2.1-FL02	1	One-way flow control valve	GRLA-1/4-QB-3/8-U		FES.534663
=V2WR1UQ52UQ2-UQ2.2-FL01	1	One-way flow control valve	GRLA-1/4-QB-3/8-U		FES.534663
=V2WR1UQ52UQ2-UQ2.2-FL02	1	One-way flow control valve	GRLA-1/4-QB-3/8-U		FES.534663
=V2WR1UQ52UQ2-UQ2.3-FL01	1	One-way flow control valve	GRLA-1/4-QB-3/8-U		FES.534663
=V2WR1UQ52UQ2-UQ2.3-FL02	1	One-way flow control valve	GRLA-1/4-QB-3/8-U		FES.534663
=V2WR1UQ52UQ2-UQ2.4-FL01	1	One-way flow control valve	GRLA-1/4-QB-3/8-U		FES.534663
=V2WR1UQ52UQ2-UQ2.4-FL02	1	One-way flow control valve	GRLA-1/4-QB-3/8-U		FES.534663
=V2WR1UQ52UQ2-UQ2.5-FL01	1	One-way flow control valve	GRLA-1/4-QB-3/8-U		FES.534663
=V2WR1UQ52UQ2-UQ2.5-FL02	1	One-way flow control valve	GRLA-1/4-QB-3/8-U		FES.534663
=V2WR1UQ52UQ2-UQ2.6-FL01	1	One-way flow control valve	GRLA-1/4-QB-3/8-U		FES.534663
=V2WR1UQ52UQ2-UQ2.6-FL02	1	One-way flow control valve	GRLA-1/4-QB-3/8-U		FES.534663
=V2WR1UQ52UQ3-QN3	0	Solenoid valve	VSVA-B-B52-ZD-A1-1T1L	FES	FES.539156
=V2WR1UQ52UQ3-UQ3.1-FL01	1	One-way flow control valve	GRLA-1/4-QB-3/8-U		FES.534663
=V2WR1UQ52UQ3-UQ3.1-FL02	1	One-way flow control valve	GRLA-1/4-QB-3/8-U		FES.534663
=V2WR1UQ52UQ3-UQ3.2-FL01	1	One-way flow control valve	GRLA-1/4-QB-3/8-U		FES.534663
=V2WR1UQ52UQ3-UQ3.2-FL02	1	One-way flow control valve	GRLA-1/4-QB-3/8-U		FES.534663
=V2WR1UQ52UQ3-UQ3.3-FL01	1	One-way flow control valve	GRLA-1/4-QB-3/8-U		FES.534663
=V2WR1UQ52UQ3-UQ3.3-FL02	1	One-way flow control valve	GRLA-1/4-QB-3/8-U		FES.534663
=V2WR1UQ52UQ3-UQ3.4-FL01	1	One-way flow control valve	GRLA-1/4-QB-3/8-U		FES.534663
=V2WR1UQ52UQ3-UQ3.4-FL02	1	One-way flow control valve	GRLA-1/4-QB-3/8-U		FES.534663
=V2WR1UQ52UQ3-UQ3.5-FL01	1	One-way flow control valve	GRLA-1/4-QB-3/8-U		FES.534663
=V2WR1UQ52UQ3-UQ3.5-FL02	1	One-way flow control valve	GRLA-1/4-QB-3/8-U		FES.534663
=V2WR1UQ52UQ3-UQ3.6-FL01	1	One-way flow control valve	GRLA-1/4-QB-3/8-U		FES.534663
=V2WR1UQ52UQ3-UQ3.6-FL02	1	One-way flow control valve	GRLA-1/4-QB-3/8-U		FES.534663
=V2WR1UQ52UQ4-QN4	0	Blanking plate	VABB-S4-1-WT		FES.539212

+ .WR1UQ51/1

Date	1/4/2023	Volvo Trucks North America	Valiant TMS	Parts list :	Drawing name:	=	
Ed.	MKLEPADLO	P6700 Side Skin Roof Outer - Cell 2V08		FES.51E-F33GCQPNMKBNMKBNMK-B-S-UL1+GS2GZBA & 45PN-R-Z-LSMX-BBU-3JL - FES.539212	F-2V08&MFS-PNEU	+ V2WR1UQ52	
Appr							Document type:
Modification	Date	Name	Original	Replaced by	MPB	22-16147	1
				Scale 1:1			112