

Engineering Release Notice	Location	Change description	Address	Version	Document release status
ERN	XX	XX			DOC_REL_STATUS Date: XXXX-XX-XX Specification count: XX

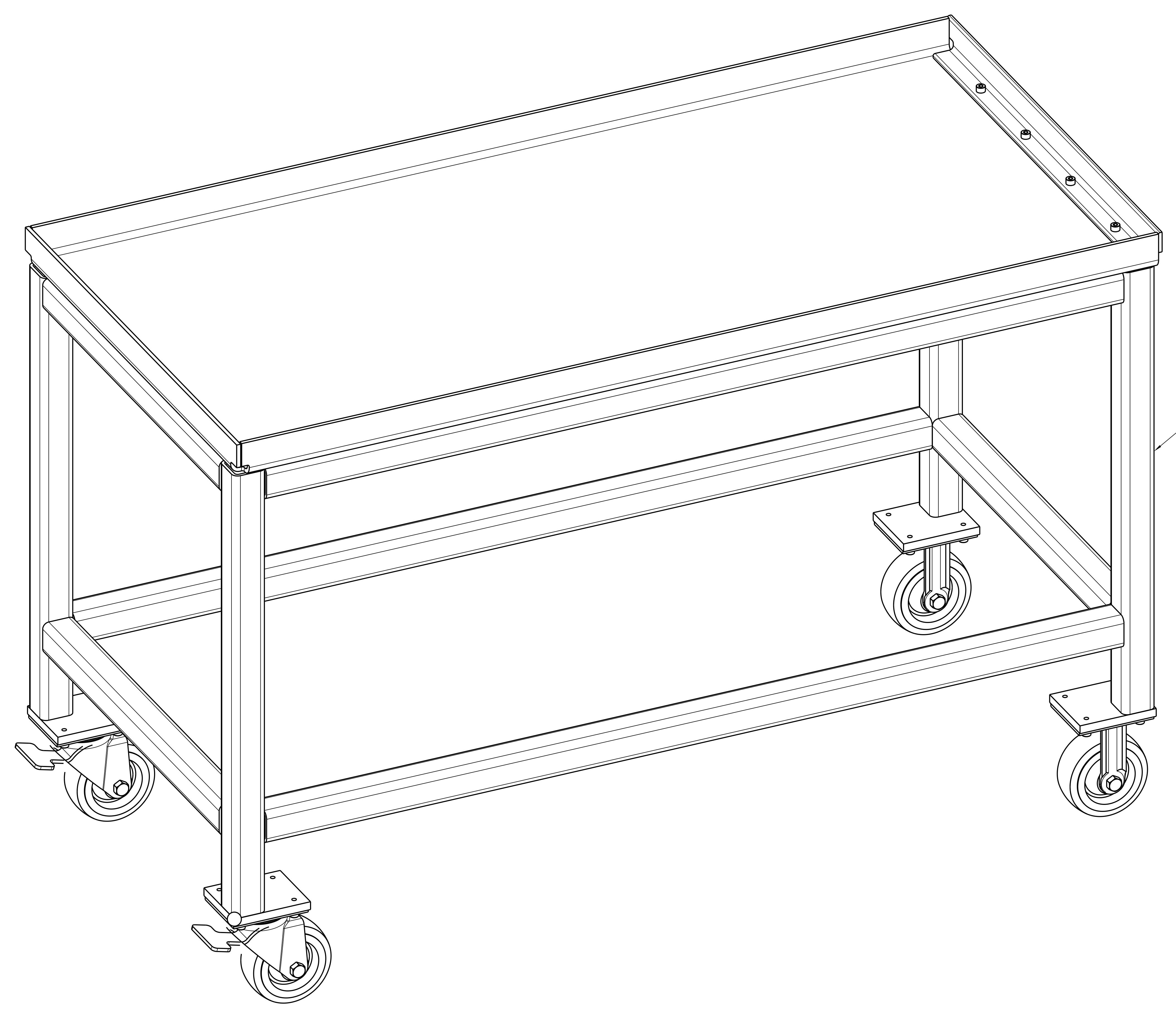

2V13\_V01U052\_U01

STA 005  
UNIT 000  
WEIGHT: 343.60\*

SHOP CHANGE			
CHANGES	DATE	CHANGED BY	
A Unit # 01 modified.	07/08/22	Actalent	

External Company	VOLVO		
External Specification	EXTERNAL SPECIFICATION		
Material	MATERIAL		
Surface Treatment	SURFACE TREATMENT		
DSM Number	DSM_NUMBER		
Symbolic, designations and general drawing method STD 101-0005			
Tolerance unless otherwise stated ISO 2768-m Sharp edges broken when function allows			
Drawn by	Date	Scale	File
ACTALENT	6/23/2022	:	A0
Approved	Date	Projection	Request reference
XX	XX	⊕	REQ_REF
The copying, distribution and utilization of this document as well as the completion of its contents to generate a third approved copy or to be printed, or to be used in the repair of the goods of a client, will be held liable for reasons of damage. All rights reserved in the event of a defect, will be held liable by the original design registration.		Document title	Version
		SUB FLOOR MANUAL REPAIR TABLE RCM-005-RT	01
		Document code	Sheet No
			1/1

16146-1005-326-1

