

STA 010  
KEY SHEET  
WEIGHT : 4065.12 #

External Company	VOLVO
External Specification	EXTERNAL SPECIFICATION
Material	MATERIAL
Surface Treatment	SURFACE TREATMENT
DSM Number	DSM_NUMBER
Symbolic designations and general drawing method STD 101-0005	
Tolerance unless otherwise stated ISO 2768-m Sharp edges broken when function allows	
Drawn by	ACTALENT
Date	6/23/2022
Scale	3:10
Projection	AO
Request reference	REQ_REF
Document title	SUB FLOOR GEO FIXTURE RCM-010-12-GEO
Document type	
Document No	=2V13-V01WR1U052
Version	01
Sheet No	1/3

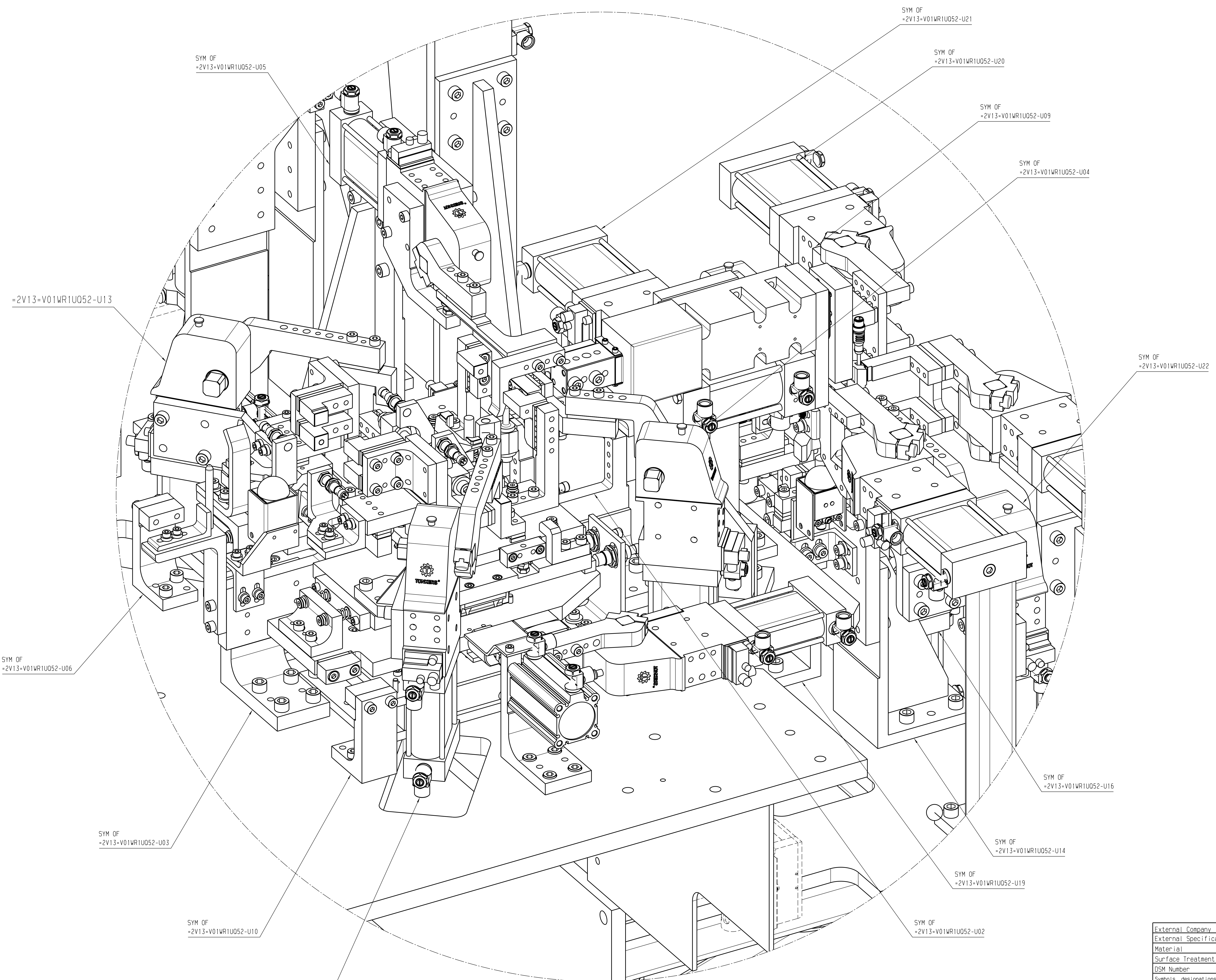

VIEW IN CIRCLE "A"  
FROM SHIT. # 1

External Company	VOLVO		
External Specification	EXTERNAL SPECIFICATION		
Material	MATERIAL		
Surface Treatment	SURFACE TREATMENT		
DSM Number	DSM_NUMBER		
Symbols, designations and general drawing method STD 101-0005			
Tolerance unless otherwise stated ISO 2768-m Sharp edges broken when function allows			
Drawn by	Date	Proj.	Req.
ACTALENT	6/23/2022	-	AO
Approved	Date	Projection	Request reference
XX	XX	1st	REQ_REF
The copying, distribution and utilization of this document as well as the compilation of its contents to generate a third document without the prior written consent of Volvo will be held liable for reasons of damage. All rights reserved in the event of the grant of a patent, utility model or industrial design registration.		Document title	Document type
		SUB FLOOR GEO FIXTURE RCM-010-12-GEO	
<b>VOLVO</b> Volvo Truck Corporation		Doc. name/Document prefix	
Document No.	Version	Sheet No.	
=2V13-V01WR1U052	01	2/3	

Engineering Release	Location	Change description	Author	Version	Document release status
XX	XX				DOC_REL_STATUS
ERN	XX	XX			Date: XXXX-XX-XX Sheet: 1 of 1

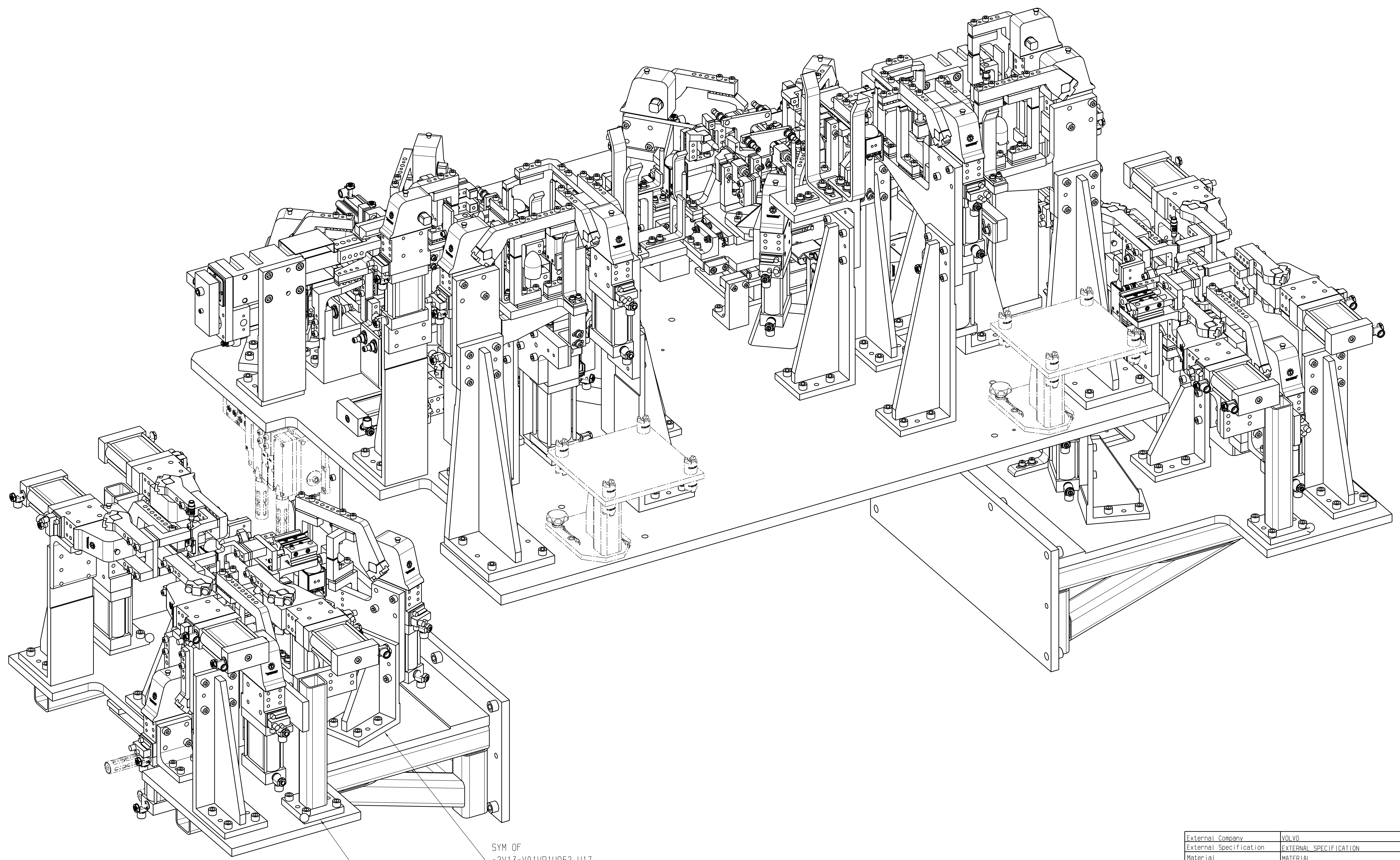

SYM OF  
=2V13=V01WR1U052-U17

SYM OF  
=2V13=V01WR1U052-U18

ISO VIEW-2

External Company	VOLVO		
External Specification	EXTERNAL SPECIFICATION		
Material	MATERIAL		
Surface Treatment	SURFACE TREATMENT		
DSM Number	DSM_NUMBER		
Symbols, designations and general drawing method STD 101-0005			
Tolerance unless otherwise stated ISO 2768-m Sharp edges broken when function allows			
Drawn by	Date	Scale	Proj
ACTALENT	6/23/2022	-	A0
Approved	Date	Projection	Request reference
XX	XX	1st	REQ_REF
<small>The copying, distribution and utilization of this document as well as the completion of its contents to generate without expressed authorization is prohibited. If there will be third parties for reasons of damage. All rights reserved in the event of the grant of a patent, will this mark of intellectual design registration.</small>			
<b>VOLVO</b> Volvo Truck Corporation		Document title SUB FLOOR GEO FIXTURE RCM-010-T2-GEO Document type	Document No =2V13=V01WR1U052
Version	01	Sheet No	3/3

SUB-DETAIL :XX  
SCALE :X:X

STRESS RELIEVE

X	000.00
Y	000.00
Z	000.00

**WELDING REQUIREMENTS**  
 WELDS SHALL NOT BE MACHINED OR DRILLED THRU  
 WELDS SHALL BE COMPLETED TO:  
 CSA W59 OR AWS D1.1 FOR STEEL  
 CSA W59.2 OR AWS D1.2 FOR ALUMINUM  
**DYNAMIC WELDMENTS**  
 ALL WELD SIZES TO BE EQUAL TO THE THINNEST CONNECTING MEMBER.

**STATIC WELDMENT:**  
 CONTINUOUS WELDS FOR ANY CONNECTING MEMBER EDGES LESS THAN OR EQUAL TO 4 TIMES THE NOMINAL WELD SIZE.  
 STITCH WELDS TO BE COMPLETED PER APPLICABLE CODE.  
 MINIMUM 50% WELD COVERAGE PER CONNECTING MEMBER EDGE.

**WELDING REQUIREMENTS**  
 WELDS SHALL NOT BE MACHINED OR DRILLED THRU  
 WELDS SHALL BE COMPLETED TO:  
 CSA W59 OR AWS D1.1 FOR STEEL  
 CSA W59.2 OR AWS D1.2 FOR ALUMINUM  
**DYNAMIC WELDMENTS**  
 ALL WELD SIZES TO BE EQUAL TO THE THINNEST CONNECTING MEMBER.

**DYNAMIC WELDMENT:**  
 CONTINUOUS WELDS ON ALL CONNECTING MEMBER EDGES ONLY (NO STITCH WELDS UNLESS OTHERWISE NOTED).  
 FOR ALUMINUM WELDMENTS ENSURE PARTS ARE PROPERLY CLEANED AND CORRECT PREHEAT IS USED.

(XXX) WELDED CONST.  
STRESS RELIEF  
PAINT CODE :  
STOCK SIZE

(XXX) STOCK SIZE :  
MATERIAL :  
PAINT CODE :  
APPROX WT =

CONTACT SURFACE

STAMP/ETCH THIS SIDE

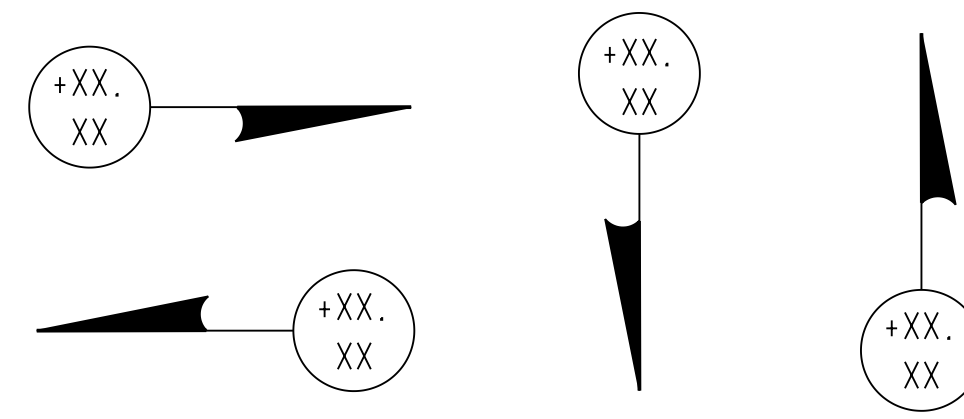

TO BODY "Y" TO BOL "Z" TO FOL "X"

LPP Data:

Weight in KG. =  
 Volume in Cc =  
 Steel or Aluminium =  
 \* of Plate components =  
 \* of Tubular components =  
 \* Tapped Holes =  
 \* Drilled Holes =  
 \* Dowel =

FINISH TO CLEAN-UP

STA XXX  
UNIT XXX

Panel name left / Panel name right  
 Panel number left / Panel number right  
 Thickness : 0.00 Direction :

POS	QTY	MATERIAL	STOCK SIZE

XXXX-XXXX-XXX-X-XXX-XXX

ZONE A GRAVER

XXXX

THIS DRAWING MAY USE BOTH INCH AND METRIC UNITS OF MEASUREMENT (\* INDICATES INCH DIMENSIONS)

MAXIMUM ALLOWANCE ROUGHNESS OF ALL METRIC

1 PLACE mm FINISH DIMENSIONS TO BE 3.2 MICRONS  
 2 PLACE mm FINISH DIMENSIONS TO BE 1.6 MICRONS  
 3 PLACE mm FINISH DIMENSIONS TO BE 0.5 MICRONS  
 ALL GROUND SURFACES TO BE 0.4 MICRONS.  
 METRIC - EXCEPT AS NOTED TOLERANCES SHALL BE:  
 1 PLACE MACHINING +/-0.3  
 1 PLACE FABRICATION +/-1.5  
 2 PLACE +/-0.08 BETWEEN MACHINED SURFACES  
 +/-0.03 BETWEEN SINGLE DOWEL AND A HEEL SURFACE  
 +/-0.03 BETWEEN DOWELS IN THE SAME PLANE  
 +/-0.10 BETWEEN DOWELS IN DIFFERENT PLANES  
 +/-0.13 TO SCREW HOLES, NON ACCUMULATIVE

ALL <TRI\_0L IN> SURFACES MUST BE FINISHED EXCEPT FOR COLD DRAWN SURFACES.

WELDMENTS:

ALL WELD FILLETS TO BE 1/4 INCH.  
 ALL "V" GROOVES TO BE 90 EXCEPT AS SHOWN.  
 ADD VENT HOLES IN ALL WELDMENTS WHERE TRAPPED AIR IS A POSSIBILITY, I.E. TUBING CAPPED AT BOTH ENDS, BOXED FORMS ETC.  
 SPOTFACE SCREW AND / OR BOLT HEAD AND / OR WASHERS IS INFRINGED UPON BY WELD BEADS.

ALL EDGES OF PART CONTACT SURFACES ON LOCATING BLOCKS AND FINGERS TO HAVE .12 INCH / 3.00 mm AFTER SPOTTING.

BUILD VENDOR TO BE RESPONSIBLE FOR ACCURACY OF STANDARD PRODUCTS AFTER ALTERATION.

DOWEL HOLE TOLERANCES	DOWEL TOLERANCE
FOR PRESS FIT USE H6	m6
FOR SLIP FIT USE F7	

MARK IDENTIFICATION AND MATERIAL NUMBERS ON DETAILS.  
 PAINT IDENTIFICATION NUMBERS ON STRUCTURAL WORK.