

DRILL & C'BORE FOR
M6 SHCS DP.AS SHOWN
(2)-PLC'S

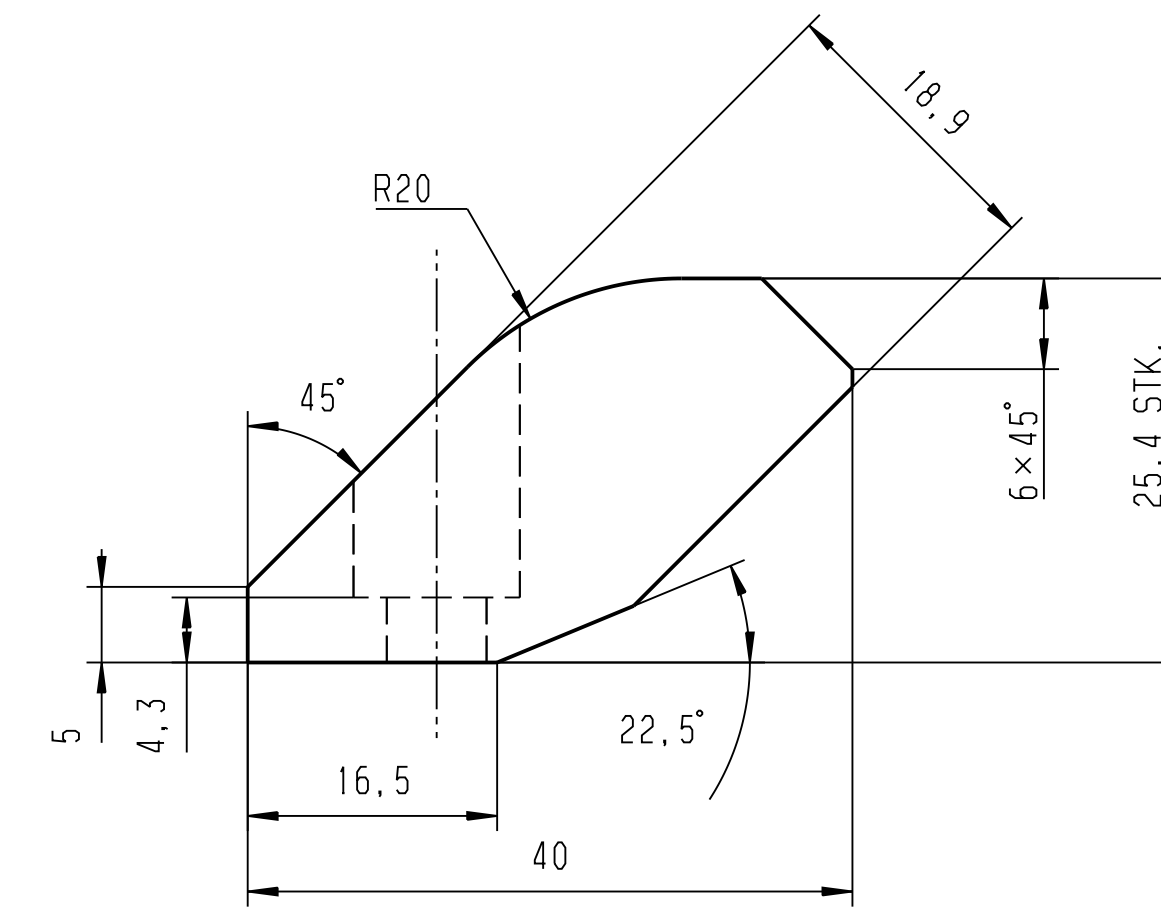
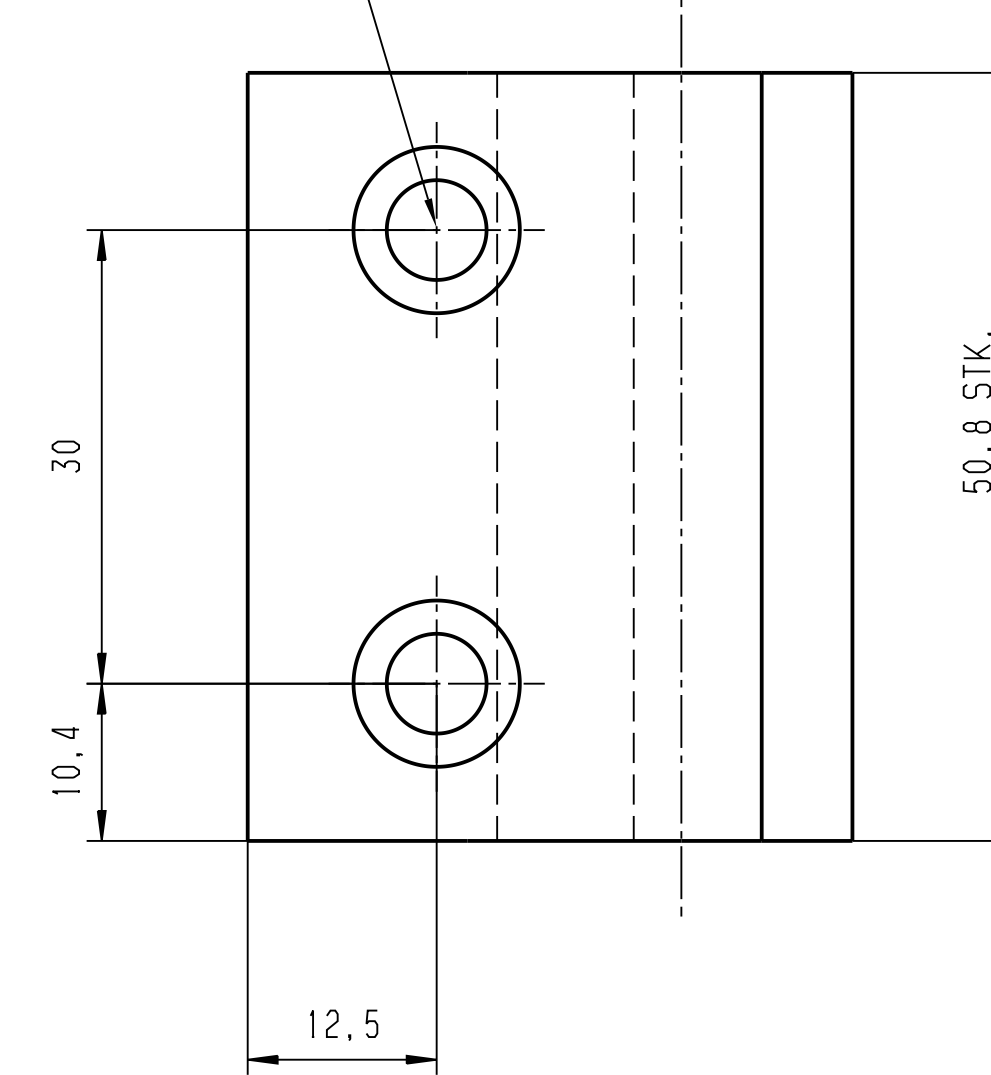

LPP Data:

- Weight in KG. =0.03 KG.
- Volume in Cc =27.76Cc.
- Steel or Aluminium =
- of Plate Components = 1
- of Tubular Components = 0
- Tapped Holes = 0
- Drilled Holes = 2
- Dowel = 0

005 BLOCK
STOCK SIZE : 1 * X 2* X 40MM
MATERIAL :UHMW
PAINT CODE :-NP
APPROX WT = 0.72#

16153-1435-704-1-001-0005

4	3	2	1
Engineering Release	Location	Change description	Subject
ERN	XX	XX	XX

STA 435
UNIT 001

THIS DRAWING MAY USE BOTH INCH AND METRIC UNITS OF MEASUREMENT
(* INDICATES INCH DIMENSIONS)

MAXIMUM ALLOWANCE ROUGHNESS OF ALL METRIC

1 PLACE mm FINISH DIMENSIONS TO BE 3.2 MICRONS
2 PLACE mm FINISH DIMENSIONS TO BE 1.6 MICRONS
3 PLACE mm FINISH DIMENSIONS TO BE 0.5 MICRONS
ALL GROUND SURFACES TO BE 0.4 MICRONS.

METRIC - EXCEPT AS NOTED TOLERANCES SHALL BE:

1 PLACE MACHINING +/-0.3
2 PLACE FABRICATION +/-1.5

2 PLACE +/-0.08 BETWEEN MACHINED SURFACES
+/-0.03 BETWEEN SINGLE DOWEL AND A HEEL SURFACE
+/-0.03 BETWEEN DOWELS IN THE SAME PLANE
+/-0.10 BETWEEN DOWELS IN DIFFERENT PLANES
+/-0.13 TO SCREW HOLES. NON ACCUMULATIVE

ALL <XTRI_OLIN> SURFACES MUST BE FINISHED EXCEPT FOR COLD DRAWN SURFACES.

WELDMENTS.
ALL WELD FILLETS TO BE 1/4 INCH.
ALL "V" GROOVES TO BE 90 EXCEPT AS SHOWN.
ADD VENT HOLES IN ALL WELDMENTS WHERE TRAPPED AIR IS A POSSIBILITY. I.E. TUBING CAPPED AT BOTH ENDS, BOXED FORMS ETC.
SPOTFACE SCREW AND / OR BOLT HEAD AND / OR WASHERS IS INFRINGED UPON BY WELD BEADS.

ALL EDGES OF PART CONTACT SURFACES ON LOCATING BLOCKS AND FINGERS TO HAVE .12 INCH / 3.00 mm AFTER SPOTTING.

BUILD VENDOR TO BE RESPONSIBLE FOR ACCURACY OF STANDARD PRODUCTS AFTER ALTERATION.

DOWEL HOLE TOLERANCES DOWEL TOLERANCE
FOR PRESS FIT USE H6 m6
FOR SLIP FIT USE F7

MARK IDENTIFICATION AND MATERIAL NUMBERS ON DETAILS.
PAINT IDENTIFICATION NUMBERS ON STRUCTURAL WORK.

External Company	VOLVO		
External Specification	EXTERNAL SPECIFICATION		
Material	MATERIAL		
Surface Treatment	SURFACE TREATMENT		
DSM Number	DSM_NUMBER		
Symbols, designations and general drawing method STD 101-0005			
Tolerance unless otherwise stated ISO 2768-m Sharp edges broken when function allows			
Drawn by	Date	Scale	File
JET	27/11/2023	2:1	A0
Approved	Date	Projection	Request reference
XX	XX	1st Angle	REQ_REF
The copyright, distribution and utilization of this document as well as the compilation of its contents to generate a third document without the prior written consent of Volvo will be held liable for reasons of damage. All rights reserved in the event of the present or future, will be held by Volvo Group.			
Document title		SUB SIDE BODY	
Document No.		DOOR STAND	
Version		XXXXXX	
Document type			
=			
Drawn: name:Document prefix			
XX			
Document No.		=2V14=V01U05	
Version		01	
Sheet No.		1/1	
VOLVO TRUCK CORPORATION			