

Table of contents

Column X: An automatically generated page was edited

F06_001

Page	Page description	supplementary page field	Date	Edited by	X
&MAA/1	Title page / cover sheet		2/22/2024	MKLEPADLO	
&MAB/1	Table of contents : &MAA/1 - &MAZ/2		3/25/2024	MKLEPADLO	
&MFS=V1GM1+KH1/1	Incoming air supply (Fixture)		2/22/2024	MKLEPADLO	
&MFS=V1GM1KH1+V1GM1KH1/1	Luggage Lid Install Fixture		3/25/2024	MKLEPADLO	
&MFS=V1GM2+KH1/1	Incoming air supply (Fixture)		3/25/2024	MKLEPADLO	
&MFS=V1GM2KH1+V1GM2KH1/1	Luggage Lid Install Fixture		3/25/2024	MKLEPADLO	
&MFS=V1GM3+KH1/1	Incoming air supply (Fixture)		2/22/2024	MKLEPADLO	
&MFS=V1GM3KH1+V1GM3KH1/1	Door To Body Install Fixture Manipulator		3/25/2024	MKLEPADLO	
&MFS=V1GM3KH1+V1GM3KH1/2	Door To Body Install Fixture		3/25/2024	MKLEPADLO	
&MFS=V1GM4+KH1/1	Incoming air supply (Fixture)		3/25/2024	MKLEPADLO	
&MFS=V1GM4KH1+V1GM4KH1/1	Door To Body Install Fixture Manipulator		3/25/2024	MKLEPADLO	
&MFS=V1GM4KH1+V1GM4KH1/2	Door To Body Install Fixture		3/25/2024	MKLEPADLO	
&MFS=V1GM5KH1+V1GM5KH1/1	Door Lift Assist		2/22/2024	MKLEPADLO	
&MFS=V1GM6KH1+V1GM6KH1/1	Door Lift Assist		2/22/2024	MKLEPADLO	
&MPB+KH1/1	Parts list : FES.MSB9-AQR:C2:J73:F8-WP-UL1 - FES.MSB9-AQR:C2:J73:F8-WP-UL1		2/22/2024	MKLEPADLO	
&MPB+V1GM1KH1/1	Parts list : 79680 - FES.534661		3/25/2024	MKLEPADLO	
&MPB+V1GM2KH1/1	Parts list : 79680 - FES.534661		3/25/2024	MKLEPADLO	
&MPB+V1GM3KH1/1	Parts list : SMC.IR3220-N04BG-Z-A - 6491K288		3/25/2024	MKLEPADLO	
&MPB+V1GM4KH1/1	Parts list : SMC.IR3220-N04BG-Z-A - 6491K288		3/25/2024	MKLEPADLO	
&MPB+V1GM5KH1/1	Parts list : 81 502 160 - SMC.NVM830-N01-13		2/22/2024	MKLEPADLO	
&MPB+V1GM6KH1/1	Parts list : 81 502 160 - SMC.NVM830-N01-13		2/22/2024	MKLEPADLO	
&MAZ/1	Amendment page		2/22/2024	MKLEPADLO	
&MAZ/2	Amendment page		2/22/2024	MKLEPADLO	

&MAA/1

&MFS=V1GM1+KH1/1

Date	3/25/2024	Volvo Trucks North America		Valiant TMS	Table of contents : &MAA/1 - &MAZ/2	Drawing name:	=	=2V14&MFS-PNEU	Project nr:	22-16175	Page	1
Ed.	MKLEPADLO	P6700 Closure Hang - Cell 2V14		Scale 1:1		Document type:	MAB				+	23
Modification	Date	Name	Original	Replacement of	Replaced by							

A2

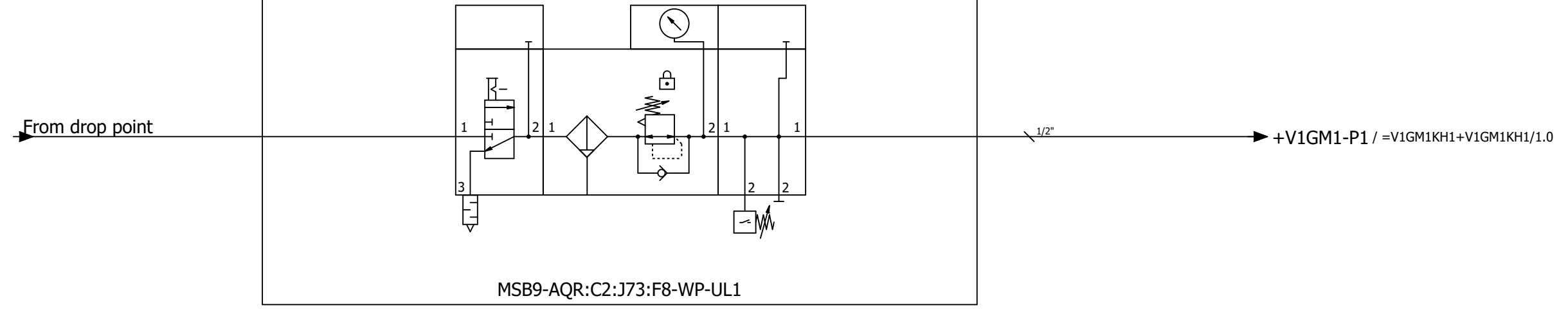

&MAB+/1

=V1GM1KH1+V1GM1KH1/1

Date		2/22/2024		Volvo Trucks North America			Valiant TMS		Incoming air supply (Fixture)		Drawing name:		= V1GM1	
Ed.		MKLEPADLO		P6700 Closure Hang - Cell 2V14			Scale 1:1				Document type:		=2V14&MFS-PNEU	
Appr.				Replacement of		Replaced by				Project nr:		22-16175		
Modification	Date	Name	Original							MFS		Page		1
												23		

A2

From drop point

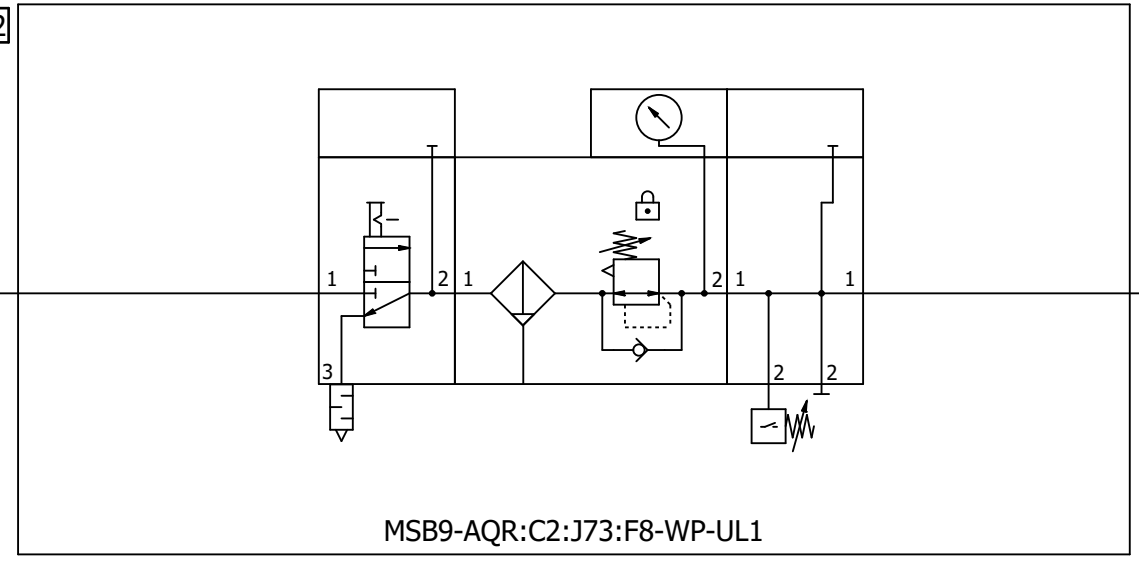

1/2"

+V1GM2-P1 / =V1GM2KH1+V1GM2KH1/1.0

=V1GM1KH1+V1GM1KH1/1

=V1GM2KH1+V1GM2KH1/1

Date		3/25/2024		Volvo Trucks North America			Valiant TMS		Incoming air supply (Fixture)		Drawing name:		= V1GM2	
Ed.		MKLEPADLO		P6700 Closure Hang - Cell 2V14			Scale 1:1				=2V14&MFS-PNEU		+ KH1	
Appr				Replacement of		Replaced by		Document type:		Project nr:		Page		
Original								MFS		22-16175		1		
Modification		Date		Name								23		

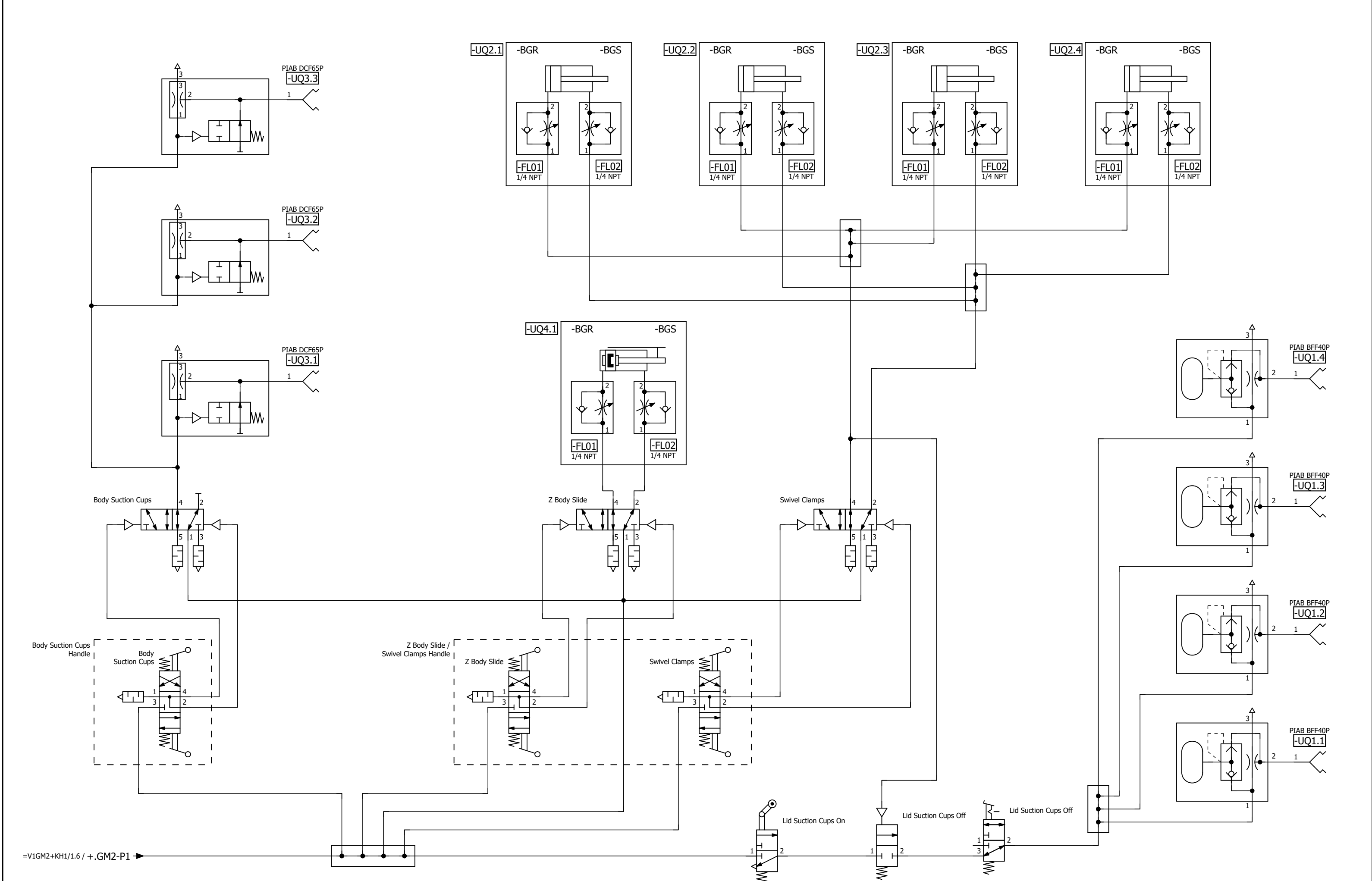

=V1GM2+KH1/1 =V1GM3+KH1/1

			Date	3/25/2024	Volvo Trucks North America	Valiant TMS	Luggage Lid Install Fixture	Drawing name:	= V1GM2KH1	
			Ed.	MKLEPADLO	P6700 Closure Hang - Cell 2V14	Scale 1:1.25		Document type:	= 2V14&MFS-PNEU	
			Appr					Replacement of	Replaced by	MFS
Modification	Date	Name	Original						Page	1
										23

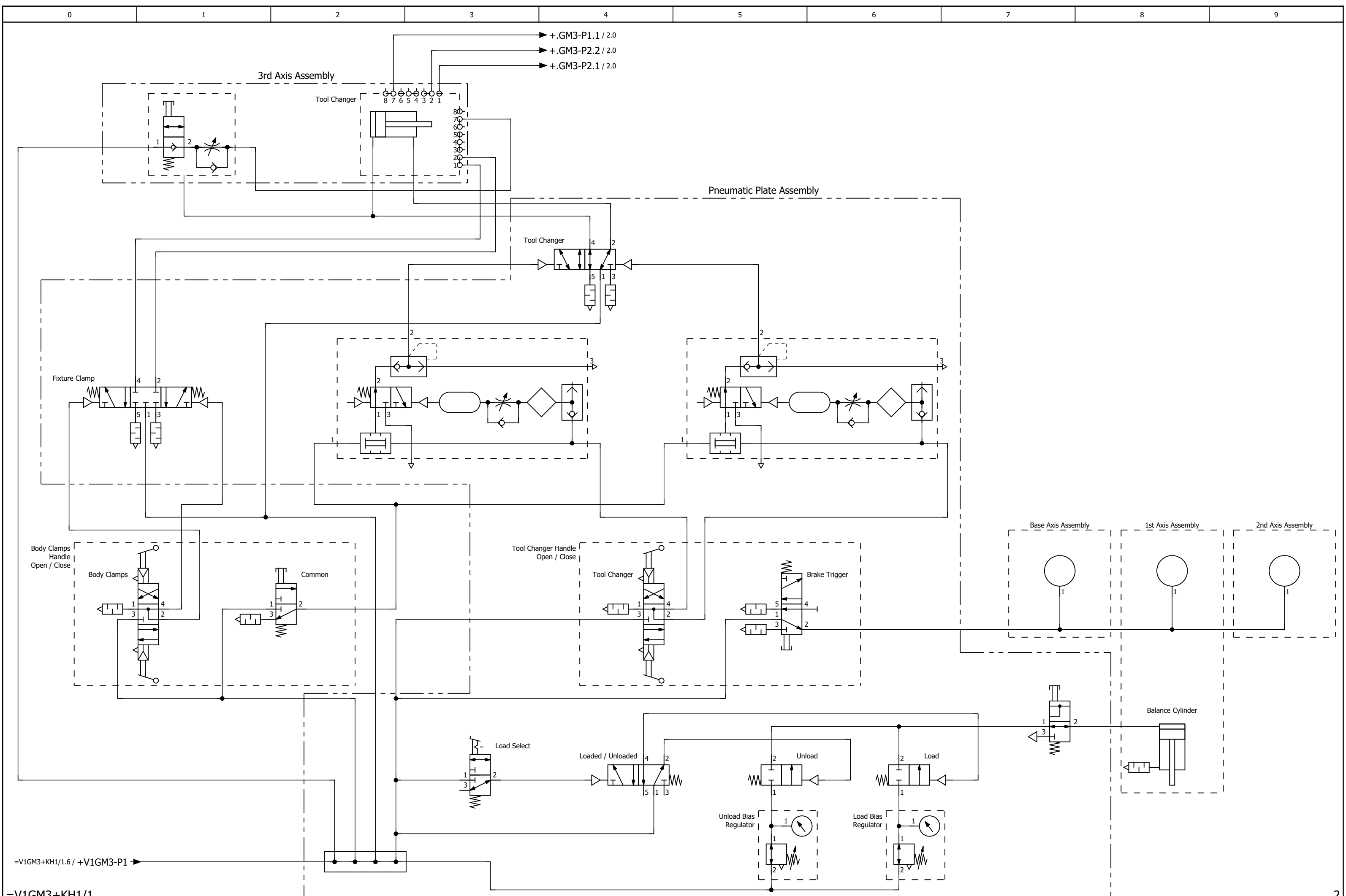

=V1GM3+KH1/1			Date	3/25/2024	Volvo Trucks North America	Valiant TMS	Door To Body Install Fixture Manipulator	Drawing name:	=V1GM3KH1	Page	1
			Ed.	MKLEPADLO				=2V14&MFS-PNEU	+ V1GM3KH1		
Modification	Date	Name	Original		P6700 Closure Hang - Cell 2V14	Scale 1:1.25		Document type:	Project nr:		23
					Replacement of	Replaced by		MFS	22-16175		

Fixture Assembly

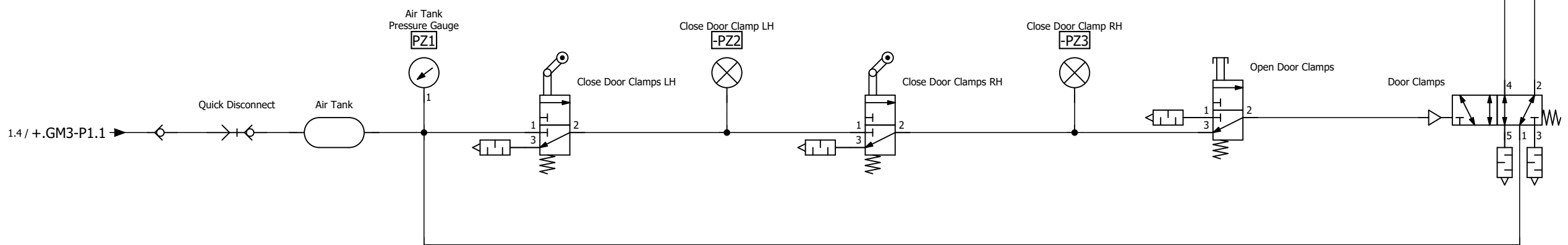
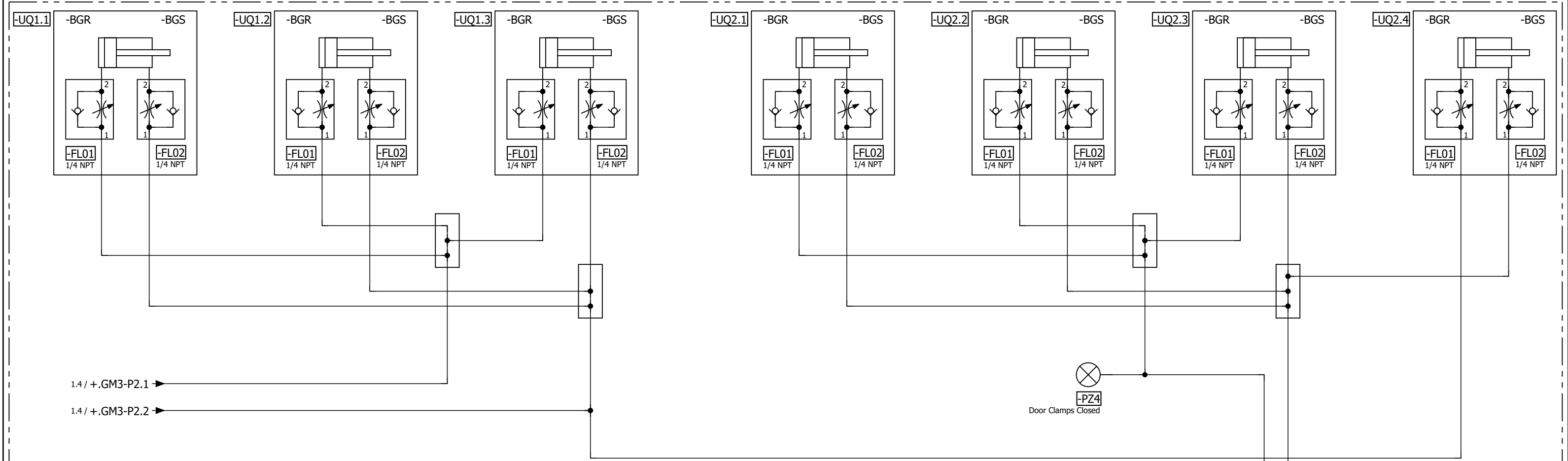

A2

From drop point

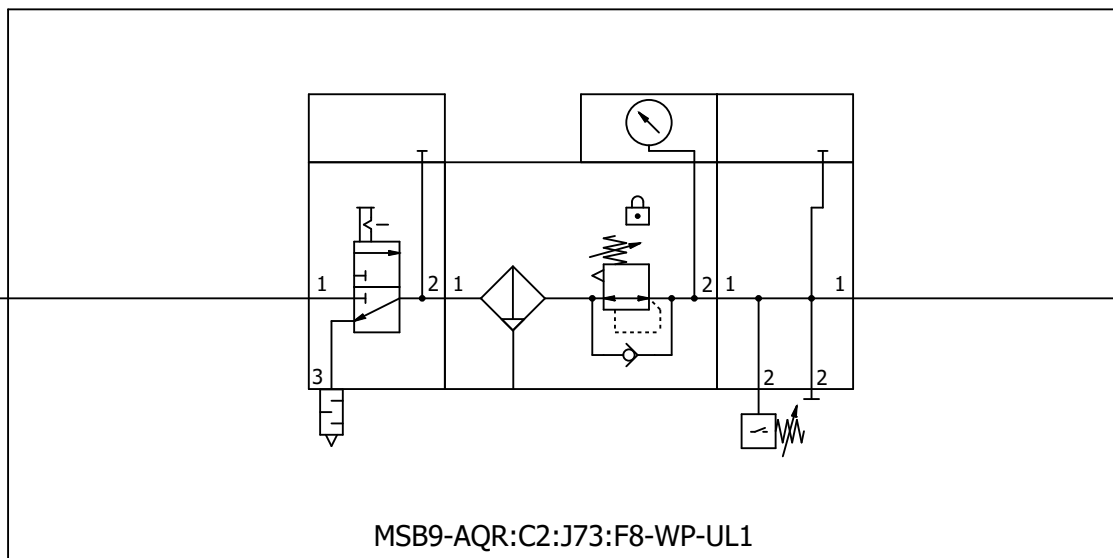

MSB9-AQR:C2:J73:F8-WP-UL1

1/2"

+V1GM4-P1 / =V1GM4KH1+V1GM4KH1/1.0

+V1GM6-P1 / =V1GM6KH1+V1GM6KH1/1.0

=V1GM3KH1+V1GM3KH1/2

=V1GM4KH1+V1GM4KH1/1

Date		3/25/2024		Volvo Trucks North America			Valiant TMS		Incoming air supply (Fixture)		Drawing name:		= V1GM4	
Ed.		MKLEPADLO		P6700 Closure Hang - Cell 2V14			Scale 1:1				=2V14&MFS-PNEU		+ KH1	
Appr				Replacement of		Replaced by		Document type:		Project nr:		Page		
Original								MFS		22-16175		1		
Modification		Date		Name								23		

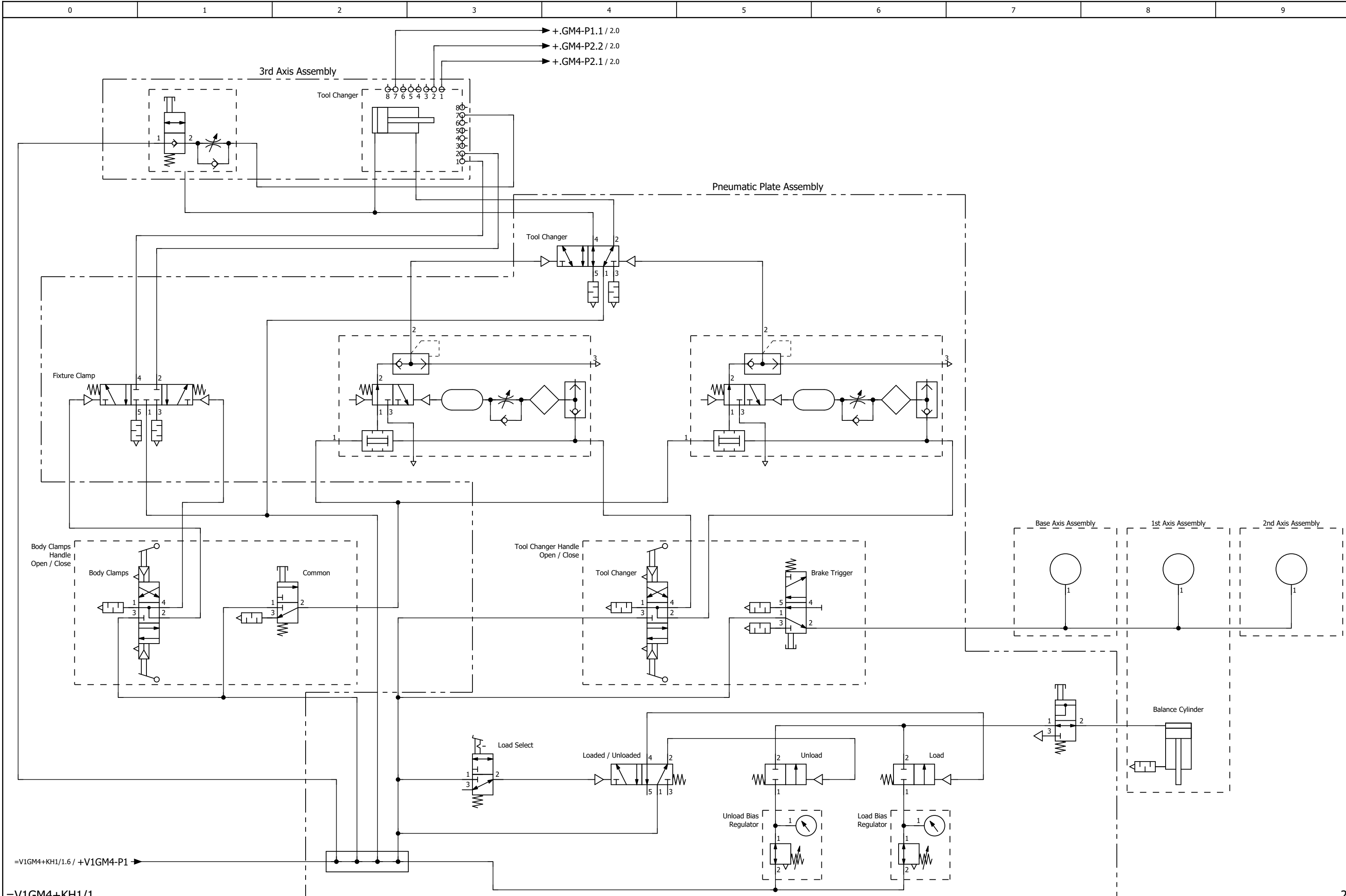

=V1GM4+KH1/1			Date	3/25/2024	Volvo Trucks North America	Valiant TMS	Door To Body Install Fixture Manipulator	Drawing name:	= V1GM4KH1	Page	1
			Ed.	MKLEPADLO				= 2V14&MFS-PNEU	+ V1GM4KH1		
Modification	Date	Name	Appr	Original	Replacement of	Replaced by	Scale 1:1.25	Document type:	Project nr:	Page	1
								MFS	22-16175		23

Fixture Assembly

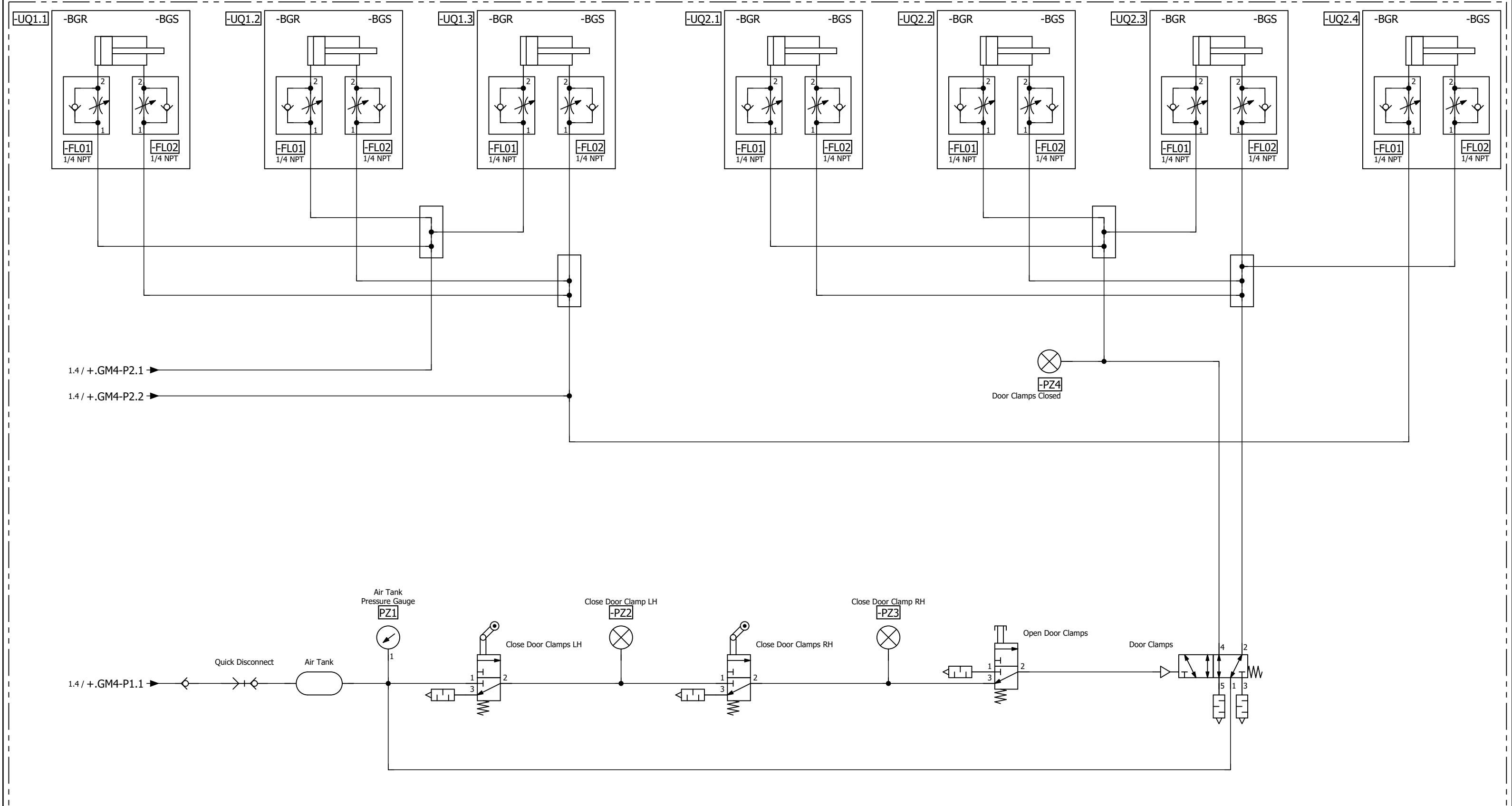

1

=V1GM5KH1+.GM5KH1/1

			Date	3/25/2024	Volvo Trucks North America	Valiant TMS	Door To Body Install Fixture	Drawing name:		= V1GM4KH1	
			Ed.	MKLEPADLO				=2V14&MFS-PNEU		+ V1GM4KH1	
			Appr					Document type:	MFS	Project nr:	22-16175
Modification	Date	Name	Original		Replacement of	Replaced by	Scale 1:1.25			Page	23

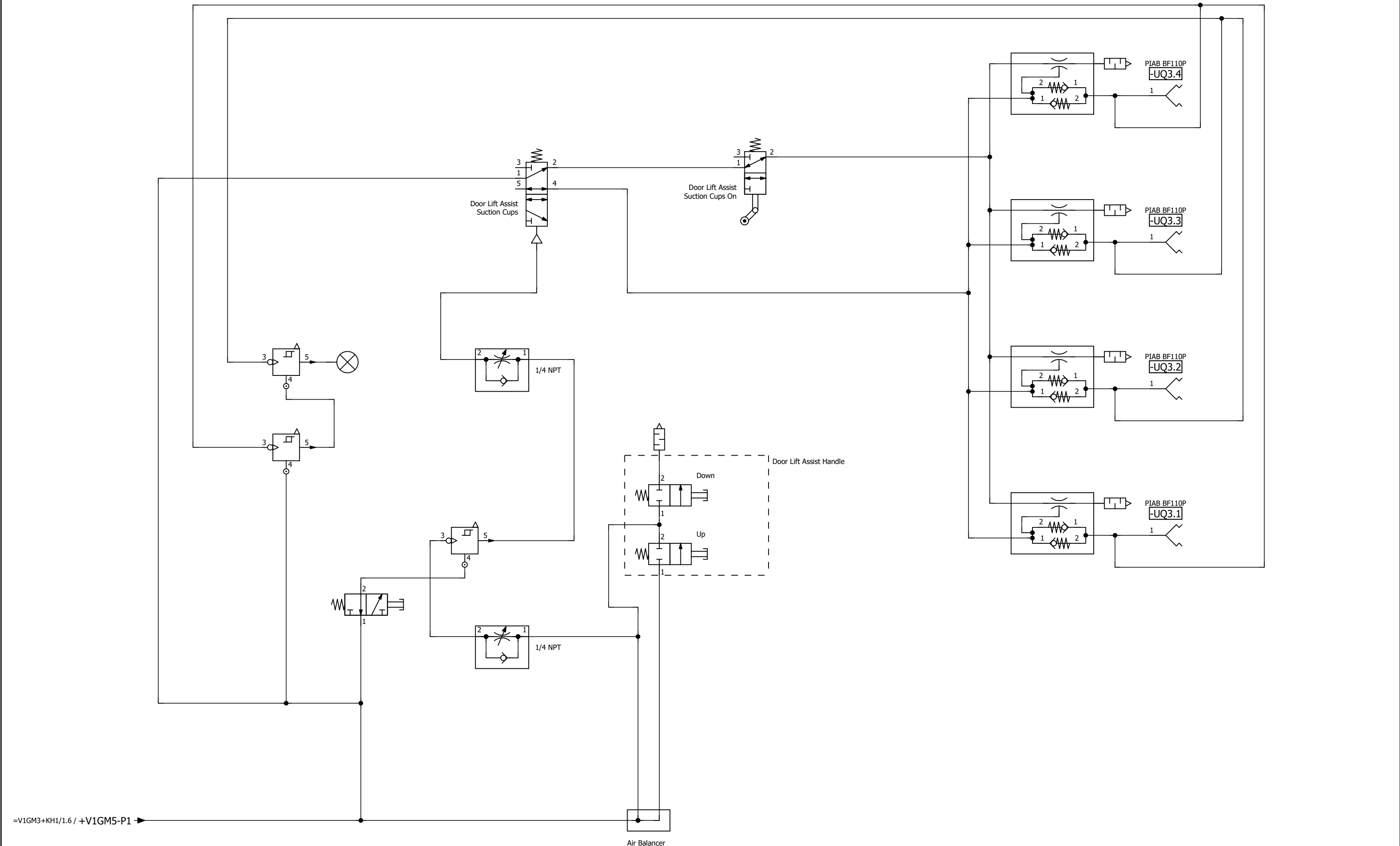

=V1GM3+KH1/1.6 / +V1GM5-P1

=V1GM4KH1+.GM4KH1/2

=V1GM6KH1+.GM6KH1/1

		Date	2/22/2024	Volvo Trucks North America		Valiant TMS		Door Lift Assist		Drawing name: =2V14&MFS-PNEU		= V1GM5KH1	
		Ed.	MKLEPADLO	P6700 Closure Hang - Cell 2V14		Scale 1:1.25				Document type: MFS		Project nr: 22-16175	
		Appr		Replacement of						Replaced by			
Modification	Date	Name	Original									Page	
												23	

Parts list

F01_001

Device tag	Quantity	Designation	Type number	Supplier	Part number
=V1GM1KH1-CH1	1	Handle	79680	UNIFIED	79680
=V1GM1KH1-CH2	1	Handle	79629	UNIFIED	79629
=V1GM1KH1-QN1	1	Right-Angle Flow Rectangular Manifolds	5469K125	MCMaster-CARR	5469K125
=V1GM1KH1-QN1.1	1	2/2 poppet valve	VM131-N01-01A	SMC	SMC.VM131-N01-01A
=V1GM1KH1-QN1.2	1	2/2 process valve	VNA201A-N10A-B	SMC	SMC.VNA201A-N10A-B
=V1GM1KH1-QN1.3	1	2/2 poppet valve	VM130-N01-34BA	SMC	SMC.VM130-N01-34BA
=V1GM1KH1-QN1.4-1	1	Right-Angle Flow Rectangular Manifolds	5469K105	MCMaster-CARR	5469K105
=V1GM1KH1-QN2.1	1	5/2 solenoid valve, 24V/DC	SYA3220-M5-F2	SMC	SMC.SYA3220-M5-F2
=V1GM1KH1-QN2.1-1	1	Right-Angle Flow Rectangular Manifolds	5469K105	MCMaster-CARR	5469K105
=V1GM1KH1-QN2.1-2	1	Right-Angle Flow Rectangular Manifolds	5469K105	MCMaster-CARR	5469K105
=V1GM1KH1-QN3.1	1	5/2 solenoid valve, 24V/DC	SYA3220-M5-F2	SMC	SMC.SYA3220-M5-F2
=V1GM1KH1-QN4.1	1	5/2 solenoid valve, 24V/DC	SYA3220-M5-F2	SMC	SMC.SYA3220-M5-F2
=V1GM1KH1-UQ2.1-FL01	1	One-way flow control valve	GRLA-1/4-QB-1/4-U	FES	FES.534661
=V1GM1KH1-UQ2.1-FL02	1	One-way flow control valve	GRLA-1/4-QB-1/4-U	FES	FES.534661
=V1GM1KH1-UQ2.2-FL01	1	One-way flow control valve	GRLA-1/4-QB-1/4-U	FES	FES.534661
=V1GM1KH1-UQ2.2-FL02	1	One-way flow control valve	GRLA-1/4-QB-1/4-U	FES	FES.534661
=V1GM1KH1-UQ2.3-FL01	1	One-way flow control valve	GRLA-1/4-QB-1/4-U	FES	FES.534661
=V1GM1KH1-UQ2.3-FL02	1	One-way flow control valve	GRLA-1/4-QB-1/4-U	FES	FES.534661
=V1GM1KH1-UQ2.4-FL01	1	One-way flow control valve	GRLA-1/4-QB-1/4-U	FES	FES.534661
=V1GM1KH1-UQ2.4-FL02	1	One-way flow control valve	GRLA-1/4-QB-1/4-U	FES	FES.534661
=V1GM1KH1-UQ4.1-FL01	1	One-way flow control valve	GRLA-1/4-QB-1/4-U	FES	FES.534661
=V1GM1KH1-UQ4.1-FL02	1	One-way flow control valve	GRLA-1/4-QB-1/4-U	FES	FES.534661

+KH1/1

+ .GM2KH1/1

Date	3/25/2024	Volvo Trucks North America		Valiant TMS	Parts list : 79680 - FES.534661	Drawing name:	=		
Ed.	MKLEPADLO	P6700 Closure Hang - Cell 2V14		Scale 1:1		=2V14&MFS-PNEU	+ V1GM1KH1		
Appr		Replacement of	Replaced by			Document type:	Project nr:	Page	1
Modification	Date	Name	Original			MPB	22-16175		23

Parts list

F01_001

Device tag	Quantity	Designation	Type number	Supplier	Part number
=V1GM2KH1-CH1	1	Handle	79680	UNIFIED	79680
=V1GM2KH1-CH2	1	Handle	79629	UNIFIED	79629
=V1GM2KH1-QN1	1	Right-Angle Flow Rectangular Manifolds	5469K125	MCMaster-CARR	5469K125
=V1GM2KH1-QN1.1	1	2/2 poppet valve	VM131-N01-01A	SMC	SMC.VM131-N01-01A
=V1GM2KH1-QN1.2	1	2/2 process valve	VNA201A-N10A-B	SMC	SMC.VNA201A-N10A-B
=V1GM2KH1-QN1.3	1	2/2 poppet valve	VM130-N01-34BA	SMC	SMC.VM130-N01-34BA
=V1GM2KH1-QN1.4-1	1	Right-Angle Flow Rectangular Manifolds	5469K105	MCMaster-CARR	5469K105
=V1GM2KH1-QN2.1	1	5/2 solenoid valve, 24V/DC	SYA3220-M5-F2	SMC	SMC.SYA3220-M5-F2
=V1GM2KH1-QN2.1-1	1	Right-Angle Flow Rectangular Manifolds	5469K105	MCMaster-CARR	5469K105
=V1GM2KH1-QN2.1-2	1	Right-Angle Flow Rectangular Manifolds	5469K105	MCMaster-CARR	5469K105
=V1GM2KH1-QN3.1	1	5/2 solenoid valve, 24V/DC	SYA3220-M5-F2	SMC	SMC.SYA3220-M5-F2
=V1GM2KH1-QN4.1	1	5/2 solenoid valve, 24V/DC	SYA3220-M5-F2	SMC	SMC.SYA3220-M5-F2
=V1GM2KH1-UQ2.1-FL01	1	One-way flow control valve	GRLA-1/4-QB-1/4-U	FES	FES.534661
=V1GM2KH1-UQ2.1-FL02	1	One-way flow control valve	GRLA-1/4-QB-1/4-U	FES	FES.534661
=V1GM2KH1-UQ2.2-FL01	1	One-way flow control valve	GRLA-1/4-QB-1/4-U	FES	FES.534661
=V1GM2KH1-UQ2.2-FL02	1	One-way flow control valve	GRLA-1/4-QB-1/4-U	FES	FES.534661
=V1GM2KH1-UQ2.3-FL01	1	One-way flow control valve	GRLA-1/4-QB-1/4-U	FES	FES.534661
=V1GM2KH1-UQ2.3-FL02	1	One-way flow control valve	GRLA-1/4-QB-1/4-U	FES	FES.534661
=V1GM2KH1-UQ2.4-FL01	1	One-way flow control valve	GRLA-1/4-QB-1/4-U	FES	FES.534661
=V1GM2KH1-UQ2.4-FL02	1	One-way flow control valve	GRLA-1/4-QB-1/4-U	FES	FES.534661
=V1GM2KH1-UQ4.1-FL01	1	One-way flow control valve	GRLA-1/4-QB-1/4-U	FES	FES.534661
=V1GM2KH1-UQ4.1-FL02	1	One-way flow control valve	GRLA-1/4-QB-1/4-U	FES	FES.534661

+ .GM1KH1/1

+ .GM3KH1/1

Date	3/25/2024	Volvo Trucks North America		Valiant TMS	Parts list : 79680 - FES.534661	Drawing name:	=		
Ed.	MKLEPADLO	P6700 Closure Hang - Cell 2V14		Scale 1:1		=2V14&MFS-PNEU	+ V1GM2KH1		
Appr		Replacement of	Replaced by			Document type:	Project nr:	Page	1
Modification	Date	Name	Original			MPB	22-16175		23

Parts list

F01_001

Device tag	Quantity	Designation	Type number	Supplier	Part number
=V1GM3KH1-A1.1	1	PRECISION REGULATOR	IR3220-N04BG-Z-A	SMC	SMC.IR3220-N04BG-Z-A
=V1GM3KH1-A1.2	1	PRECISION REGULATOR	IR3220-N04BG-Z-A	SMC	SMC.IR3220-N04BG-Z-A
=V1GM3KH1-C1	1	AIR TANK	FRS9125	FIRESTONE	FRS9125
=V1GM3KH1-CH1	1	Handle	BPA9140	KNIGHT.GLOBAL	BPA9140
=V1GM3KH1-CH2	1	Handle	BPTA9100	KNIGHT.GLOBAL	BPTA9100
=V1GM3KH1-PZ1	1	Gauge	GA36-P10-01-X30	SMC	SMC.GA36-P10-01-X30
=V1GM3KH1-PZ2	1	Indicator	VR3100-N01G	SMC	SMC.VR3100-N01G
=V1GM3KH1-PZ3	1	Indicator	VR3100-N01G	SMC	SMC.VR3100-N01G
=V1GM3KH1-PZ4	1	Indicator	VR3100-N01G	SMC	SMC.VR3100-N01G
=V1GM3KH1-QD1	1	Quick coupling socket	63548	MERLIN	63548
=V1GM3KH1-QL1	1	Brake Caliper	0733-0120	TOLOMATIC	0733-0120
=V1GM3KH1-QL2	1	Brake Caliper	0722-0001	TOLOMATIC	0722-0001
=V1GM3KH1-QL3	1	Brake Caliper	0705-0001	TOLOMATIC	0705-0001
=V1GM3KH1-QN1	1	Right-Angle Flow Rectangular Manifolds	5469K125	MCMaster-CARR	5469K125
=V1GM3KH1-QN1.1-1	1	Right-Angle Flow Rectangular Manifolds	5469K105	MCMaster-CARR	5469K105
=V1GM3KH1-QN1.1-2	1	Right-Angle Flow Rectangular Manifolds	5469K105	MCMaster-CARR	5469K105
=V1GM3KH1-QN1.10	1	5/3 solenoid valve, 24V/DC	SYA5320-01-F2	SMC	SMC.SYA5320-01-F2
=V1GM3KH1-QN2	1	CHECK VALVE	AKH06-00	SMC	SMC.AKH06-00
=V1GM3KH1-QN2.1	1	2/2 poppet valve	VM131-N01-01A	SMC	SMC.VM131-N01-01A
=V1GM3KH1-QN2.2	1	2/2 poppet valve	VM131-N01-01A	SMC	SMC.VM131-N01-01A
=V1GM3KH1-QN2.3	1	2/2 poppet valve	NVM430-N01-30R	SMC	SMC.NVM430-N01-30R
=V1GM3KH1-QN2.4	1	5/2 solenoid valve, 24V/DC	SYA5120-01-F2	SMC	SMC.SYA5120-01-F2
=V1GM3KH1-QN2.4-1	1	Right-Angle Flow Rectangular Manifolds	5469K125	MCMaster-CARR	5469K125
=V1GM3KH1-QN2.4-2	1	Right-Angle Flow Rectangular Manifolds	5469K125	MCMaster-CARR	5469K125
=V1GM3KH1-QN2.10	1	Pilot Check Valve	ASP330F-U01-06-X352	SMC	SMC.ASP330F-U01-06-X352
=V1GM3KH1-QN3.1	1	2/2 poppet valve	VM130-N01-34BA	SMC	SMC.VM130-N01-34BA
=V1GM3KH1-QN3.2	1	5/2 solenoid valve,24V/DC	SYA5140-02N	SMC	SMC.SYA5140-02N
=V1GM3KH1-QN3.2-1	1	2/2 process valve	VNA201A-N15A-B	SMC	SMC.VNA201A-N15A-B
=V1GM3KH1-QN3.2-2	1	2/2 process valve	VNA201A-N15A-B	SMC	SMC.VNA201A-N15A-B
=V1GM3KH1-QN3.3	1	PRESSURE RELIEF VALVE	KEB12	SMC	SMC.KEB12
=V1GM3KH1-QN4.1	1	5/2 solenoid valve, 24V/DC	SYA3220-M5-F2	SMC	SMC.SYA3220-M5-F2
=V1GM3KH1-TC1	1	Tool Changer	P1401-TC120-8	SMC	RSP.P1401-TC120-8
=V1GM3KH1-THC1	1	Valve	VR51-C06B	SMC	SMC.VR51-C06B
=V1GM3KH1-THC2	1	Valve	VR51-C06B	SMC	SMC.VR51-C06B
=V1GM3KH1-UQ1.1-FL01	1	One-way flow control valve	GRLA-1/4-QB-1/4-U	FES	FES.534661
=V1GM3KH1-UQ1.1-FL02	1	One-way flow control valve	GRLA-1/4-QB-1/4-U	FES	FES.534661
=V1GM3KH1-UQ1.2-FL01	1	One-way flow control valve	GRLA-1/4-QB-1/4-U	FES	FES.534661
=V1GM3KH1-UQ1.2-FL02	1	One-way flow control valve	GRLA-1/4-QB-1/4-U	FES	FES.534661
=V1GM3KH1-UQ1.3-FL01	1	One-way flow control valve	GRLA-1/4-QB-1/4-U	FES	FES.534661
=V1GM3KH1-UQ1.3-FL02	1	One-way flow control valve	GRLA-1/4-QB-1/4-U	FES	FES.534661
=V1GM3KH1-UQ2.1-FL01	1	One-way flow control valve	GRLA-1/4-QB-1/4-U	FES	FES.534661
=V1GM3KH1-UQ2.1-FL02	1	One-way flow control valve	GRLA-1/4-QB-1/4-U	FES	FES.534661
=V1GM3KH1-UQ2.2-FL01	1	One-way flow control valve	GRLA-1/4-QB-1/4-U	FES	FES.534661
=V1GM3KH1-UQ2.2-FL02	1	One-way flow control valve	GRLA-1/4-QB-1/4-U	FES	FES.534661
=V1GM3KH1-UQ2.3-FL01	1	One-way flow control valve	GRLA-1/4-QB-1/4-U	FES	FES.534661
=V1GM3KH1-UQ2.3-FL02	1	One-way flow control valve	GRLA-1/4-QB-1/4-U	FES	FES.534661
=V1GM3KH1-UQ2.4-FL01	1	One-way flow control valve	GRLA-1/4-QB-1/4-U	FES	FES.534661
=V1GM3KH1-UQ2.4-FL02	1	One-way flow control valve	GRLA-1/4-QB-1/4-U	FES	FES.534661
=V1GM3KH1-UQ3.3	1	Air Cylinder	6491K288	MCMaster-CARR	6491K288

+ .GM2KH1/1

+ .GM4KH1/1

Date	3/25/2024	Volvo Trucks North America		Valiant TMS	Parts list : SMC.IR3220-N04BG-Z-A - 6491K288	Drawing name:	=		
Ed.	MKLEPADLO	P6700 Closure Hang - Cell 2V14		Scale 1:1		Document type:	MPB	Project nr:	22-16175
Appr		Replacement of	Replaced by				+ V1GM3KH1	Page	1
Modification	Date	Name	Original						23

Parts list

F01_001

Device tag	Quantity	Designation	Type number	Supplier	Part number
=V1GM4KH1-A1.1	1	PRECISION REGULATOR	IR3220-N04BG-Z-A	SMC	SMC.IR3220-N04BG-Z-A
=V1GM4KH1-A1.2	1	PRECISION REGULATOR	IR3220-N04BG-Z-A	SMC	SMC.IR3220-N04BG-Z-A
=V1GM4KH1-C1	1	AIR TANK	FRS9125	FIRESTONE	FRS9125
=V1GM4KH1-CH1	1	Handle	BPA9140	KNIGHT.GLOBAL	BPA9140
=V1GM4KH1-CH2	1	Handle	BPTA9100	KNIGHT.GLOBAL	BPTA9100
=V1GM4KH1-PZ1	1	Gauge	GA36-P10-01-X30	SMC	SMC.GA36-P10-01-X30
=V1GM4KH1-PZ2	1	Indicator	VR3100-N01G	SMC	SMC.VR3100-N01G
=V1GM4KH1-PZ3	1	Indicator	VR3100-N01G	SMC	SMC.VR3100-N01G
=V1GM4KH1-PZ4	1	Indicator	VR3100-N01G	SMC	SMC.VR3100-N01G
=V1GM4KH1-QD1	1	Quick coupling socket	63548	MERLIN	63548
=V1GM4KH1-QL1	1	Brake Caliper	0733-0120	TOLOMATIC	0733-0120
=V1GM4KH1-QL2	1	Brake Caliper	0722-0001	TOLOMATIC	0722-0001
=V1GM4KH1-QL3	1	Brake Caliper	0705-0001	TOLOMATIC	0705-0001
=V1GM4KH1-QN1	1	Right-Angle Flow Rectangular Manifolds	5469K125	MCMaster-CARR	5469K125
=V1GM4KH1-QN1.1-1	1	Right-Angle Flow Rectangular Manifolds	5469K105	MCMaster-CARR	5469K105
=V1GM4KH1-QN1.1-2	1	Right-Angle Flow Rectangular Manifolds	5469K105	MCMaster-CARR	5469K105
=V1GM4KH1-QN1.10	1	5/3 solenoid valve, 24V/DC	SYA5320-01-F2	SMC	SMC.SYA5320-01-F2
=V1GM4KH1-QN2	1	CHECK VALVE	AKH06-00	SMC	SMC.AKH06-00
=V1GM4KH1-QN2.1	1	2/2 poppet valve	VM131-N01-01A	SMC	SMC.VM131-N01-01A
=V1GM4KH1-QN2.2	1	2/2 poppet valve	VM131-N01-01A	SMC	SMC.VM131-N01-01A
=V1GM4KH1-QN2.3	1	2/2 poppet valve	NVM430-N01-30R	SMC	SMC.NVM430-N01-30R
=V1GM4KH1-QN2.4	1	5/2 solenoid valve, 24V/DC	SYA5120-01-F2	SMC	SMC.SYA5120-01-F2
=V1GM4KH1-QN2.4-1	1	Right-Angle Flow Rectangular Manifolds	5469K125	MCMaster-CARR	5469K125
=V1GM4KH1-QN2.4-2	1	Right-Angle Flow Rectangular Manifolds	5469K125	MCMaster-CARR	5469K125
=V1GM4KH1-QN2.10	1	Pilot Check Valve	ASP330F-U01-06-X352	SMC	SMC.ASP330F-U01-06-X352
=V1GM4KH1-QN3.1	1	2/2 poppet valve	VM130-N01-34BA	SMC	SMC.VM130-N01-34BA
=V1GM4KH1-QN3.2	1	5/2 solenoid valve,24V/DC	SYA5140-02N	SMC	SMC.SYA5140-02N
=V1GM4KH1-QN3.2-1	1	2/2 process valve	VNA201A-N15A-B	SMC	SMC.VNA201A-N15A-B
=V1GM4KH1-QN3.2-2	1	2/2 process valve	VNA201A-N15A-B	SMC	SMC.VNA201A-N15A-B
=V1GM4KH1-QN3.3	1	PRESSURE RELIEF VALVE	KEB12	SMC	SMC.KEB12
=V1GM4KH1-QN4.1	1	5/2 solenoid valve, 24V/DC	SYA3220-M5-F2	SMC	SMC.SYA3220-M5-F2
=V1GM4KH1-TC1	1	Tool Changer	P1401-TC120-8	SMC	RSP.P1401-TC120-8
=V1GM4KH1-THC1	1	Valve	VR51-C06B	SMC	SMC.VR51-C06B
=V1GM4KH1-THC2	1	Valve	VR51-C06B	SMC	SMC.VR51-C06B
=V1GM4KH1-UQ1.1-FL01	1	One-way flow control valve	GRLA-1/4-QB-1/4-U	FES	FES.534661
=V1GM4KH1-UQ1.1-FL02	1	One-way flow control valve	GRLA-1/4-QB-1/4-U	FES	FES.534661
=V1GM4KH1-UQ1.2-FL01	1	One-way flow control valve	GRLA-1/4-QB-1/4-U	FES	FES.534661
=V1GM4KH1-UQ1.2-FL02	1	One-way flow control valve	GRLA-1/4-QB-1/4-U	FES	FES.534661
=V1GM4KH1-UQ1.3-FL01	1	One-way flow control valve	GRLA-1/4-QB-1/4-U	FES	FES.534661
=V1GM4KH1-UQ1.3-FL02	1	One-way flow control valve	GRLA-1/4-QB-1/4-U	FES	FES.534661
=V1GM4KH1-UQ2.1-FL01	1	One-way flow control valve	GRLA-1/4-QB-1/4-U	FES	FES.534661
=V1GM4KH1-UQ2.1-FL02	1	One-way flow control valve	GRLA-1/4-QB-1/4-U	FES	FES.534661
=V1GM4KH1-UQ2.2-FL01	1	One-way flow control valve	GRLA-1/4-QB-1/4-U	FES	FES.534661
=V1GM4KH1-UQ2.2-FL02	1	One-way flow control valve	GRLA-1/4-QB-1/4-U	FES	FES.534661
=V1GM4KH1-UQ2.3-FL01	1	One-way flow control valve	GRLA-1/4-QB-1/4-U	FES	FES.534661
=V1GM4KH1-UQ2.3-FL02	1	One-way flow control valve	GRLA-1/4-QB-1/4-U	FES	FES.534661
=V1GM4KH1-UQ2.4-FL01	1	One-way flow control valve	GRLA-1/4-QB-1/4-U	FES	FES.534661
=V1GM4KH1-UQ2.4-FL02	1	One-way flow control valve	GRLA-1/4-QB-1/4-U	FES	FES.534661
=V1GM4KH1-UQ3.3	1	Air Cylinder	6491K288	MCMaster-CARR	6491K288

MODIFIED DRAWINGS NOT REVISED IN THE ORIGINAL				DRAWINGS FOR REVISION			REPLACE AFTER REV. BY ORIGINAL		
DATE	SIGN.	DRAWING NR:	SHEET NR:	DATE	SIGN.	REV. AV	DATE	SIGN.	REV.

