

# 5

### Gearboxes & Lubrication

<b>Standard mounting positions</b> .....	<b>55</b>
<b>Position of the terminal box</b> .....	<b>57</b>
Position of the terminal box and the cable entry points (BG and BF) .....	57
Position of the terminal box and the cable entry points (BK and BS).....	58
<b>Gearboxes</b> .....	<b>59</b>
Radial and axial forces at the output shaft .....	59
Dimensions and fits of output shafts and keyways .....	59
Installing transmission elements .....	59
Gear with solid shaft .....	59
Gear with hollow shaft .....	59
Shrink disc coupling .....	59
Torque restraint .....	60
Notes for installing shaft mount gears with hollow shaft and keyway .....	60
<b>Lubricants</b> .....	<b>61</b>
Lubricant quantities.....	62
Lubricant quantities, BG-series gears.....	63
Lubricant quantities, BG20-01R .....	64
Lubricant quantities, BF-series gears .....	65
Lubricant quantities, BK-series gears .....	66
Lubricant quantities, BS-series gears .....	67
Lubricant quantities, pre-stage gears (Z) .....	68
Lubrication quantity for intermediate gear .....	69
<b>Threaded plugs</b> .....	<b>70</b>
Position of threaded plugs.....	70
-BG-series gears.....	70
-BG-20-01R.....	71
-BF-series gears.....	72
-BK-series gears .....	73
-BS-series gears .....	74
-pre-stage gears (Z).....	75
-in the System Cover Design with Standard Geared Motor.....	76
-in the System Cover Design with foreign motor or gear design with input shaft .....	77

# Energy Efficient Geared Motors

## AC Variable Speed

---

5

# Gearboxes & Lubrication

## Standard mounting positions

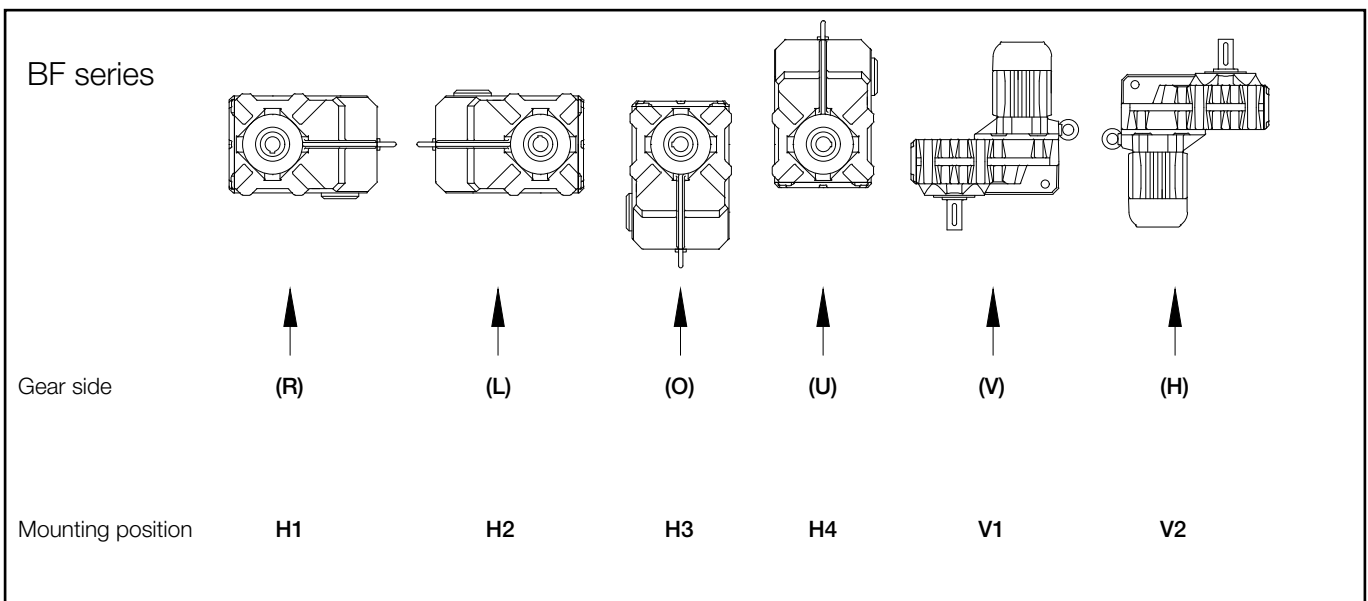
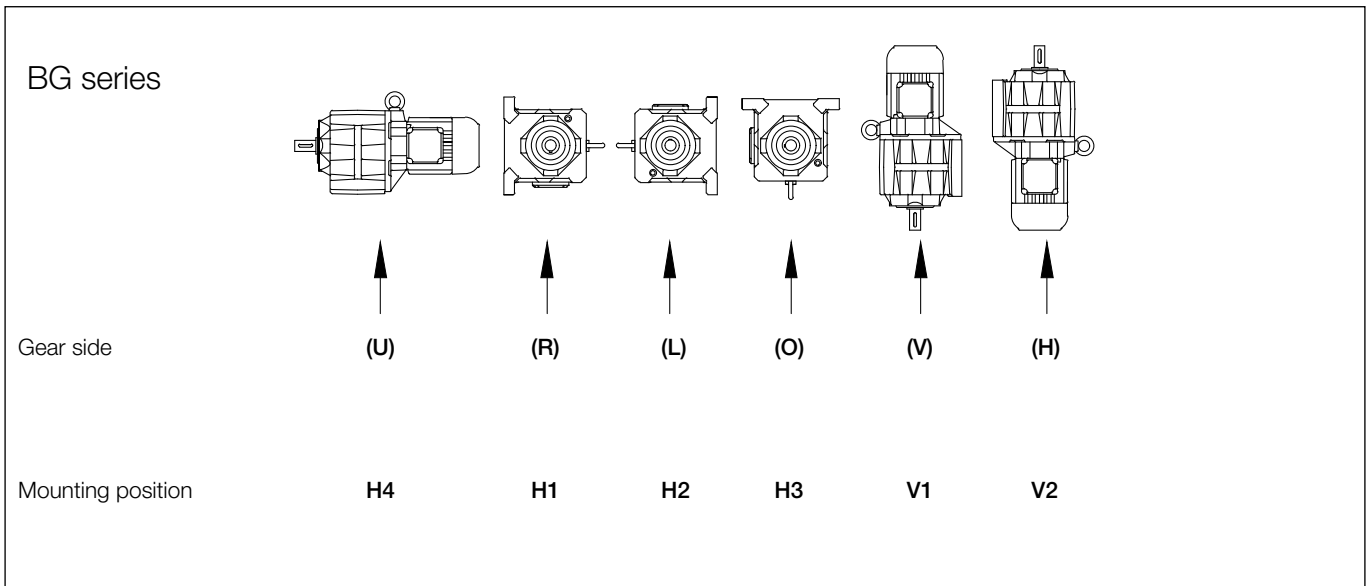

# Gearboxes & Lubrication

## Standard mounting positions

Reihe BK

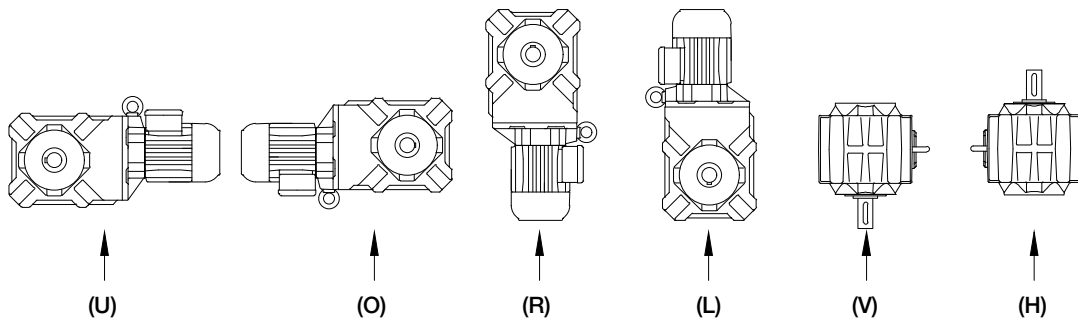

Getriebeseite

(U)

(O)

(R)

(L)

(V)

(H)

Einbaulage

H1

H2

H3

H4

V1

V2

5

Reihe BS

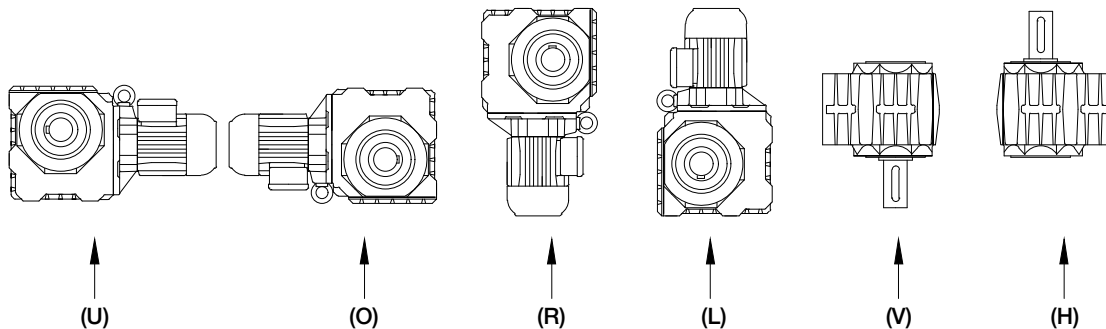

Getriebeseite

(U)

(O)

(R)

(L)

(V)

(H)

Einbaulage

H1

H2

H3

H4

V1

V2

### Position of the terminal box and the cable entry points (BG and BF)

The standard position of the terminal box for helical-gear and shaft-mounted geared motors is position I. Cables may be introduced from side A or C.

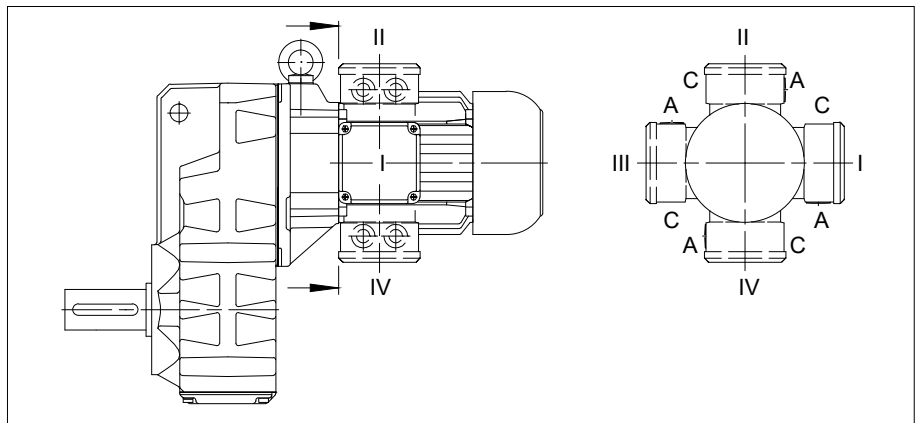
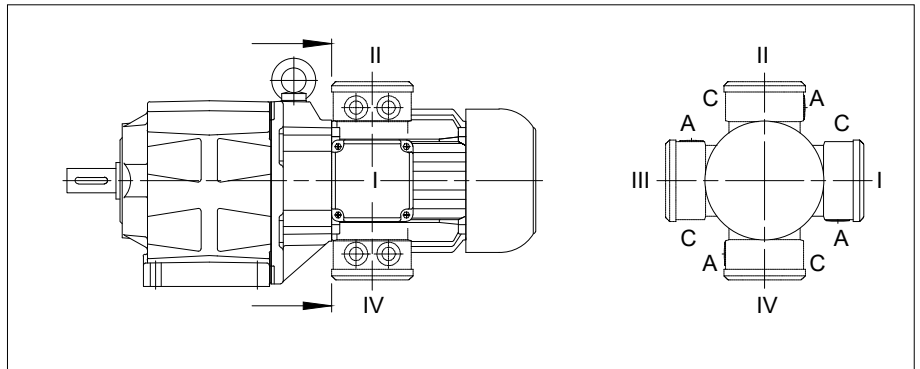

Turning or rotating the gearbox in space in the different mounting positions according to DIN 42950 does not influence the marking as shown. The details of the terminal box always show the position of the terminal box and the cable entry in relation to the gearbox and not in space. The mounting according to DIN 42950 is to be given separately.

# Gearboxes & Lubrication

## Position of the terminal box

### Position of the terminal box and the cable entry points (BK and BS)

The standard position of the terminal box for bevel-gear and worm-gear motors is position II.

Cable entry through side A or side C is possible

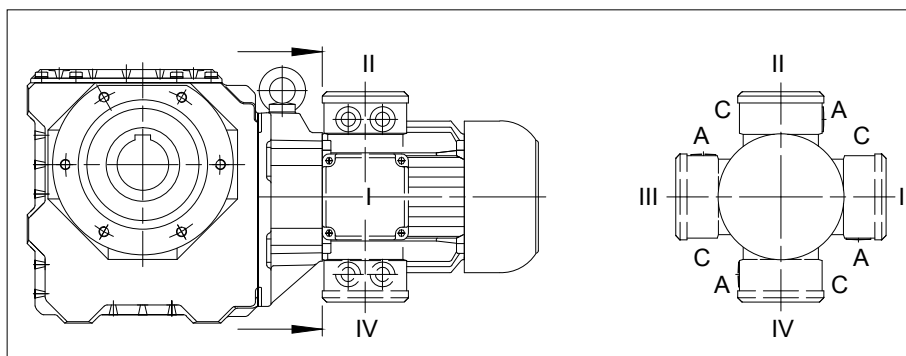
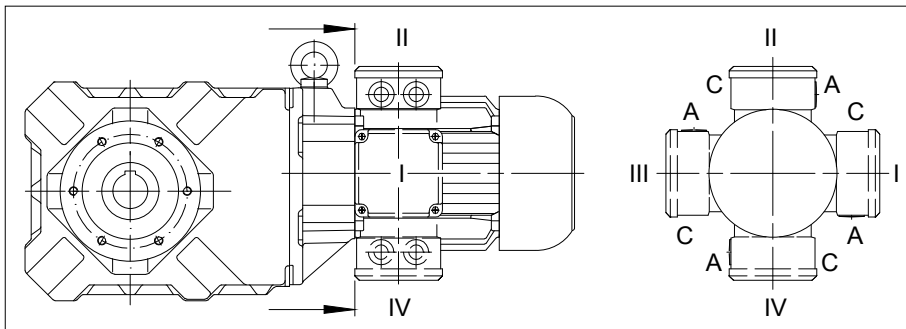

Turning or rotating the gearbox in space in the different mounting positions according to DIN 42950 does not influence the marking as shown. The details of the terminal box always show the position of the terminal box and the cable entry in relation to the gearbox and not in space. The mounting according to DIN 42950 is to be given separately.

### Radial and axial forces at the output shaft

The output shafts and output-shaft bearings are matched to the motor torques. It is advisable to locate the drive-transmission element's point of application as close as possible to the shaft collar to ensure that the load imposed by external radial forces is not unnecessarily high. Permissible values for radial forces referred to the output shaft centreline are listed in the selection tables. Please consult us if your application involves extra-high axial loading.

### Dimensions and fits of output shafts and keyways

Output shaft and second shaft stub, keyway and key are in compliance with the DIN standards and ISO fits listed below:

#### Solid shaft

Shaft diameter	to D = 50 mm in ISO k6 (DIN 748 Page1) as of D = 50 mm in ISO m6 (DIN 748 Page 1)
Keyway	ISO P9 (DIN 6885 Page 1)
Key, height	ISO h9 (DIN 6885 Page 1 and DIN 6880)
Bore - customer	ISO H7

#### Hollow shaft with keyway

Bore diameter	ISO H7 (DIN 748)
Keyway	ISO JS9 (DIN 6885 Page 1)
Key, height	ISO h9 (DIN 6885 Page 1 and DIN 6880)
Customer shaft	ISO h6

#### Hollow shaft for shrink-on disc coupling (SSV)

Outside diameter	ISO f7
Inside diameter	ISO H7
Customer shaft	ISO h6

### Installing transmission elements

#### Note:

Gearboxes using torque reaction by means of a flange (Code 2.; 3; 4.; 7.; 8.) or torque arm (Code 5.), must have the side for the torque reaction the same as where the radial force on the output shaft occurs (see rubber buffers for torque arms)! Please consult the factory for other designs.

### Gear with solid shaft

Always exercise meticulous care when fitting transmission elements onto output shafts and, whenever possible, use the DIN 332 tapped bore provided for this purpose. Fitting is usually easier if the transmission element can be heated to approximately 100° C for installation. Dimension the locating bore to ISO H7.

Gears with solid shaft at each end (gear code -.3/): alignment of the two keys is subject to the DIN 7168 tolerances, the degree of accuracy is "fine".

### Gear with hollow shaft

Hollow shafts usually engage solid shafts of the driven machinery. The gear unit must be mounted such as to be free of constraint and be fixed axially (e.g. by means of assembly help acc. following description "notes for installing shaft mount gears with hollow shaft and keyway"). Special contract provision must be made if the hollow shaft has to guide the solid shaft or, for any other reason, close out-of-round tolerance referenced to a point on the gear housing (such as a flange, for instance) is required.

### Shrink disc coupling

A shrink disc coupling (SSV) can transmit high torque from the non-grooved hub to the smooth shaft. The SSV is easily secured and released, using commercially available bolts. SSVs are the ideal supplement for shaft mount gears. The maximum transmittable torque for the selected shrink discs when fitted and mounted according to instructions is above the breakaway torque of the respective motors classified as standard (for classification of shrink disc sizes see chapter 11, 12, 13 "Additional dimensional drawings for Shrink disc coupling")

### Torque restraint

Shaft-mounted geared motors require a suitable torque restraint to resist the reaction torque. Shaft-mounted gears have cast torque arms as standard. Bevel gears and worm gears are available with bolt-on torque arms on request. The torque arm is screwed onto the front "V" on the side of the gear unit. It is always important to ensure that the torque arm does not create excessive constraining forces due to the driven shaft running untrue, for example. Excessive play can result in excessive shock torques in switching or reversing operations. Consequently, we recommend the use of pre-tensioned rubber damping elements. These rubber buffers are part of the scope of supply for designs with a torque arm (see chapter 11, 12., 13 dimensional drawings "Rubber buffer for torque restraint")

### Notes for installing shaft mount gears with hollow shaft and keyway

#### (1) Attaching the hollow shaft to the customer shaft

Threaded bolt (d) is screwed into the end thread of the shaft to be driven. By tightening the nut, apply force to thrust plate (b) and locating ring (c) to draw the gear unit onto the shaft.

#### (2) Axial fastening

Pressure piece (b) is rotated and fitted against retaining ring (c) using fixing screw (a).

#### (3) Removing

Extractor (f) is fitted between the end face of the shaft and retainer ring (c). Tighten press-off screw (e) against the end of the shaft and pull the gear unit off the shaft.

Manufacturing drawings for the required parts are available on request. These parts are not included in the scope of supply.

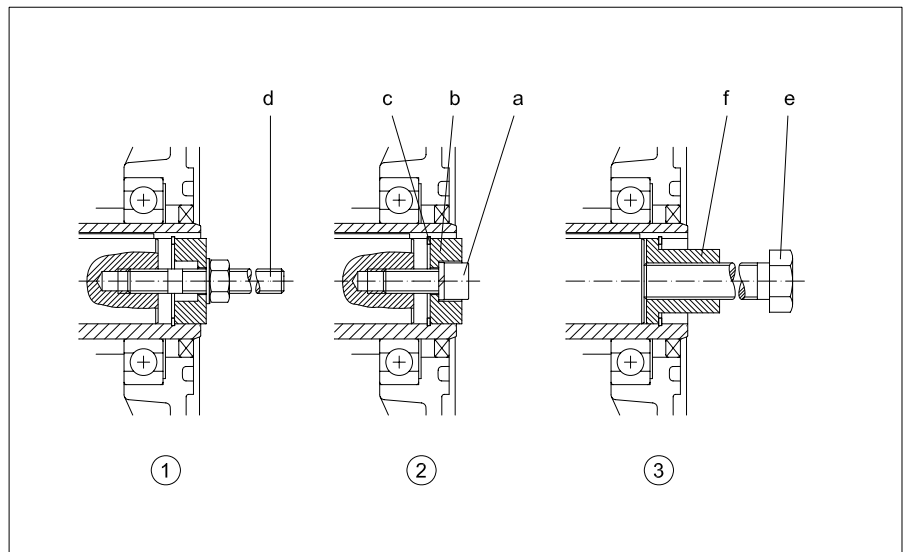

Detailed information on shaft-mounted gear units, bevel-gear units and worm-gear units is available (see chapter 11, 12., 13 dimensional drawings "Tools for fitting shaft-mounted gear with hollow shaft and keyway").

### Gear ventilation

The lifetime of the gearbox lubricant increases the better it is protected from negative environmental influences. Should the oil level or the gearbox ratio cause a very high lubricant temperature, the gearbox will be supplied as standard with a breather plug. Either on request or for corresponding high ambient temperatures, all gearboxes from size 10 can be supplied with a breather plug.

For the position of the threaded plugs see chapter 5 threaded plugs.

### Output shaft seals









All size 10 and larger gears are available with double seals for the output shaft on request and at extra cost. Double seals are particularly effective if the output shaft points down and as protection against external influences



### Lubricants

The drives are shipped ready-filled with gear lubricant. Lubricated in this way, the gear units are suitable for ambient temperatures in the range -20 °C to + 40 °C. The quantity of lubricant is optimised for the desired installed position as is stated on the nameplate. The type of lubricant is stated in the Operating Instructions. Lubricants for other temperature ranges or special applications available on request.

Wear-protective EP gear oils as indicated in the following table have proven particularly effective:

Manufacturer	Lubricant type					
	Mineral Oil	Synthetic Oil			USDA H1 Oil	
	ISO VG 220	ISO VG 68		ISO VG 220	ISO VG 460	ISO VG 220
	Standard oil for gearboxes in the series <b>BF06-BF90</b> <b>BG04-BG100</b> <b>BK60-BK90</b>	Low temperature oil for gearboxes in the series <b>BF06-BF90</b> <b>BG04-BG100</b>	<b>BK06-BK90</b> <b>BM09-BM40</b> <b>BS02-BS40</b>	Standard oil for gearboxes in the series <b>BS02-BS10</b> <b>BK06-BK10</b> <b>BM09-BM40</b> High temperature oil for gearboxes in the series <b>BS02-BS10</b> <b>BK06-BK10</b> <b>BF06-BF90</b> <b>BG04-BG100</b> <b>BK60-BK90</b> <b>BM09-BM10</b>	Standard oil for gearboxes in the series <b>BS20-BS40</b> <b>BK17-BK50</b> <b>BM20-BM40</b> High temperature oil for gearboxes <b>BS20-BS40</b> <b>BK17-BK50</b> <b>BM20-BM40</b>	Food and Beverage Industry Oil for gearboxes in the series <b>BF06-BF90</b> <b>BG04-BG100</b> <b>BK06-BK90</b> <b>BM09-BM40</b> <b>BS02-BS40</b>
<b>AGIP</b> 	BLASIA 220 [13 02 08]	—	—	BLASIA S 220 [13 02 06]	BLASIA S 460 [13 02 06]	—
<b>BECHER RHUS</b> 	STAROIL G 220 [13 02 08]	—	BERUSYNTH EP 68 [13 02 06]	BERUSYNTH EP 220 [13 02 06]	BERUSYNTH EP 460 [13 02 06]	BERUSYNTH EP 220 H1 [13 02 06]
<b>CASTROL</b> 	ALPHA EP 220 [13 02 08] ALPHA SP 220 [13 02 08] OPTIGEAR EP 220 [13 02 08] OPTIGEAR 1100/220 [13 02 08]	Alphasyn T68 [13 02 06]	—	ALPHASYN PG 220 [13 02 06] OPTIGEAR 800/220 [13 02 06] OPTIGEAR 1300/220 [13 02 06] ALPHASYN GS 220 [13 02 06]	ALPHASYN PG 460 [13 02 06] OPTIGEAR 800/460 [13 02 06] OPTIGEAR 1300/460 [13 02 06] ALPHASYN GS 460 [13 02 06]	OPTILEB GT 220 (CLP-HC) [13 02 06] OPTILEB GT 1800/220 (CLP-PG) [13 02 08]
<b>CHEVRON</b>	Meropa 220 [13 02 08] GEARTEX EP-A SAE 85W-90 [13 02 06]	—	Meropa Synlu- be WS 68 [13 02 06]	Meropa Synlu- be WS 220 [13 02 06]	Meropa Synlu- be WS 460 [13 02 06]	Chevron lubricating oils FM 220 (USA) [13 02 06]
<b>FUCHS</b> 	RENOLIN CLP 220 [13 02 08] RENOLIN CLPF 220 SUPER [13 02 08] RENOLIN CLP 220 PLUS [13 02 08]	RENOLIN UNI- SYN CLP 68 [13 02 06]	RENOLIN PG 68 [13 02 06]	RENOLIN PG 220 [13 02 06]	RENOLIN PG 460 [13 02 06]	CASSIDA FLUID GL 220 [13 02 06]
<b>KLÜBER</b> 	KLÜBEROIL GEM 1-220 N [13 02 08]	—	KLÜBER- SYNTH GH 6-80 [13 02 06]	KLÜBERSYNTH GH 6-220 [13 02 06]	KLÜBERSYNTH GH 6-460 [13 02 06]	KLÜBEROIL 4UH1-220 N [13 02 06] KLÜBERSYNTH UH1 6-220 [13 02 06]
<b>MOBIL</b> 	MOBILGEAR 600 XP 220 [13 02 08]	MOBIL SHC 626 [13 02 06]	—	MOBIL SHC Gear 220 [13 02 06] MOBIL SHC 630 [13 02 06]	MOBIL SHC Gear460 [13 02 06] MOBIL SHC 634 [13 02 06]	MOBIL SHC CIBUS 220 [13 02 06]
<b>OEST</b> 	Gearol 220 [13 02 06]	—	—	—	—	—
<b>SHELL</b>	OMALA S2 GX220 [13 02 08]	—	—	OMALA S4 WE 220 [13 02 06]	OMALA S4 WE 460 [13 02 06]	—
<b>TOTAL</b> 	CARTER EP 220 [13 02 08] CARTER XEP 220 [13 02 06]	—	—	CARTER SY 220 [13 02 06]	CARTER SY 460 [13 02 06]	NEVASTANE SL220 [13 02 06] NEVASTANE EP 220 [13 02 06] NEVASTANE SY 220 [13 02 06]
<b>WINTERSHALL</b>	SRS ERSOLAN 220 [13 02 08]	—	—	—	—	—

[...] European Waste Catalogue Code (Decision 2001/118/CE)

### **Important:**

Synthetic gear oils of a Polyglykol base (e.g. PGLP...) must be disposed of separately to mineral oil as **Special Waste** .

So long as the ambient temperature does not fall below  $-20\text{ °C}$  the international definition of the viscosity class at  $40\text{ °C}$  according to ISO 3448 and DIN 51519 ISO the viscosity class VG220 (SAE90) is recommended according, in North America AGMA 5EP.

For lower temperatures it is recommended to use oils of a lower nominal viscosity with a corresponding better starting characteristic, for instance a PGLP with a nominal viscosity VG68 (SAE80) or AGMA 2EP respectively. These types of oil can already be necessary at a temperature around the freezing point, if the break away torque of a drive is reduced by some smooth starting device or if the motor has a relatively low power

### **Lubricant quantities**

5

The preferred quantity of lubricant for the planned type of installation is stated on the motor's rating plate (symbol "oil can"). When topping up care should be taken to ensure that, depending on the fitting position, gearwheels and rolling contact bearings positioned at the top are also properly oiled. In special versions the oil level mark should be noted. Information about the quantity of lubricant required for other types of installation can be obtained from the factory

### Lubricant quantities, BG-series gears

#### Gear-housing with flange or foot

Flange (Code-2./Code-3./Code-4./Code-7.)

Foot with threaded holes (Code -6.)

Foot with clearance holes (Code-9.)

Completely machined (Code -8.)

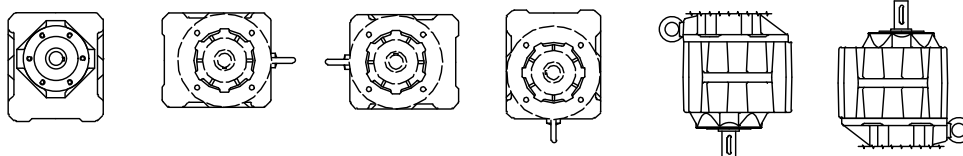

#### Foot housing

cast foot with clearance holes (Code -1.)

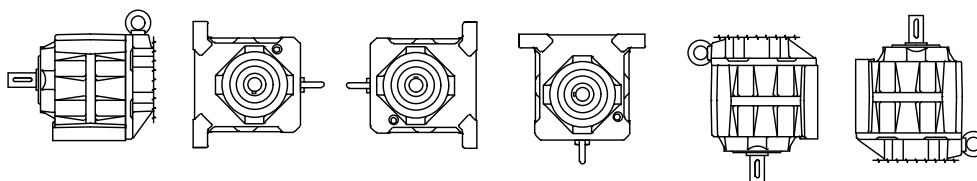

Gearbox type		H4	H1	H2	H3	V1	V2
BG04	*	0,03	0,03	0,03	0,03	0,05	0,05
	**	0,05	0,05	0,05	0,05	0,1	0,05
BG05	*	0,05	0,05	0,05	0,05	0,08	0,08
	**	0,08	0,08	0,08	0,08	0,16	0,8
BG06	*	0,08	0,08	0,08	0,08	0,15	0,15
	**	0,12	0,12	0,12	0,12	0,24	0,15
BG10	*	0,65	0,65	0,65	0,85	1,05	0,85
	**	0,45	0,45	0,45	0,6	0,75	0,6
BG15	**	0,4	0,4	0,4	0,35	0,62	0,55
BG20	*	0,8	0,8	0,8	1,1	1,4	1,1
	**	0,6	0,6	0,6	1,0	1,15	0,9
BG30	*	1,0	1,0	1,0	1,7	2,4	1,6
	**	1,0	1,0	1,0	1,7	2,3	1,7
BG40	*	1,7	1,7	1,7	2,5	3,5	2,1
	**	1,7	1,7	1,7	2,5	3,5	2,1
BG50	*	3,0	3,0	3,0	4,5	5,5	3,3
	**	3,0	3,0	3,0	4,5	5,5	3,3
BG60	*	5,5	5,5	5,5	7,0	10,9	6,4
	**	5,5	5,5	5,5	7,0	10,9	6,4
BG70		6,5	6,5	6,5	8,0	13,5	9,0
BG80		11,0	11,0	11,0	11,0	22,5	15,0
BG90		19,0	19,0	19,0	19,0	40,0	26,0
BG100		35,0	35,0	55,0	50,0	66,0	50,0
* Flange Housing							
** Foot Housing							
Lubrication quantity in litre							

# Gearboxes & Lubrication

## Lubricants

### Lubricant quantities, BG20-01R

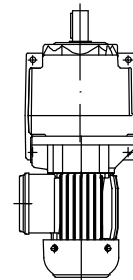
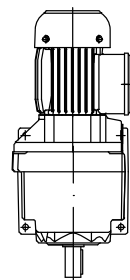
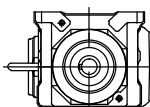
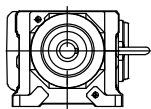
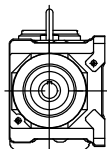

5

Gearbox type	H4	H1	H2	H3	V1	V2
BG20R	0,8	1,0	0,8	1,4	1,65	1,0
Lubrication quantity in litre						

### Lubricant quantities, BF-series gears

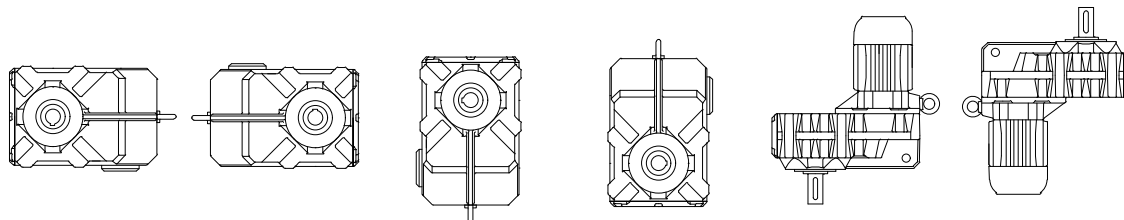

Gear type	H1	H2	H3	H4	V1	V2
BF06	0,25	0,25	0,25	0,37	0,35	0,3
BF10	0,85	0,85	0,85	1,1	1,45	1,5
BF20	1,3	1,3	1,3	1,7	2,2	2,25
BF30	1,7	1,7	1,7	2,2	3,2	3,0
BF40	2,7	2,7	2,7	3,5	4,9	4,8
BF50	3,8	3,8	3,8	5,0	6,7	6,7
BF60	6,7	6,7	6,7	9,0	12,3	12,0
BF70	12,2	12,2	12,2	16,0	24,2	21,8
BF80	17,0	17,0	17,0	21,0	32,2	27,5
BF90	32,0	32,0	32,0	41,0	62,0	53,0
Lubrication quantity in litre						

# Gearboxes & Lubrication

## Lubricants

### Lubricant quantities, BK-series gears

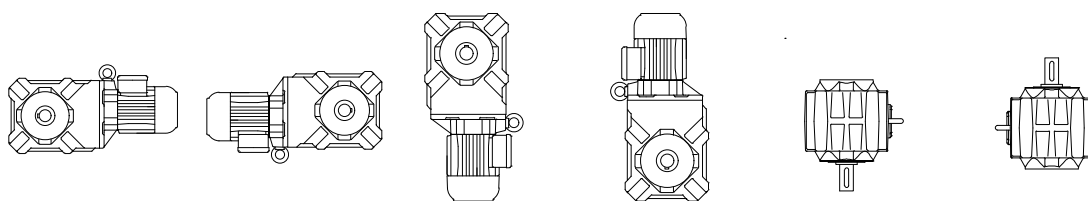

Gear type	H1	H2	H3	H4	V1	V2
BK06	0,15	0,23	0,29	0,31	0,18	0,23
BK10	0,83	0,83	0,92	1,75	0,92	0,92
BK17	1,0	1,7	1,8	2,6	1,3	1,8
BK20	1,5	1,5	1,6	2,9	1,65	1,65
BK30	2,2	2,2	2,3	4,4	2,4	2,4
BK40	3,5	3,5	3,5	7,0	3,7	3,7
BK50	5,8	5,8	5,8	11,5	6,0	6,0
BK60	6,0	8,7	6,9	12,0	8,6	8,6
BK70	10,2	15,0	11,5	20,5	13,5	14,5
BK80	18,0	25,5	19,0	37,0	23,5	25,5
BK90	33,0	48,0	36,0	69,0	45,0	48,0

Lubrication quantity in litre

5

### Lubricant quantities, BS-series gears

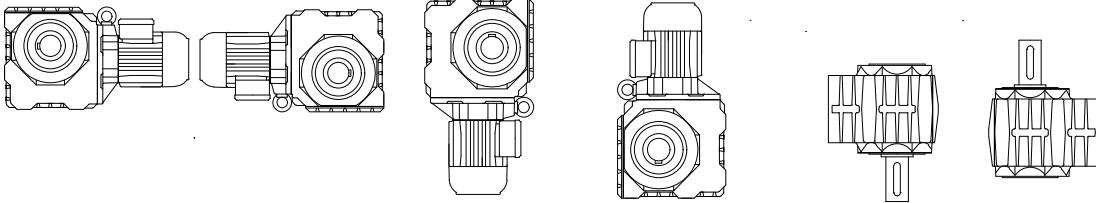

Gear type	H1	H2	H3	H4	V1	V2
BS02	0,06	0,06	0,06	0,06	0,06	0,06
BS03	0,17	0,17	0,17	0,17	0,17	0,17
BS04	0,11	0,17	0,11	0,2	0,11	0,11
BS06	0,24	0,36	0,24	0,45	0,24	0,24
BS10	0,9	1,3	0,9	1,6	0,9	0,9
BS20	1,5	2,1	1,5	2,7	1,5	1,5
BS30	2,2	3,0	2,2	3,8	2,2	2,2
BS40	3,5	4,7	3,5	6,0	3,5	3,5
Lubrication quantity in litre						

# Gearboxes & Lubrication

## Lubricants

### Lubricant quantities, pre-stage gears (Z)

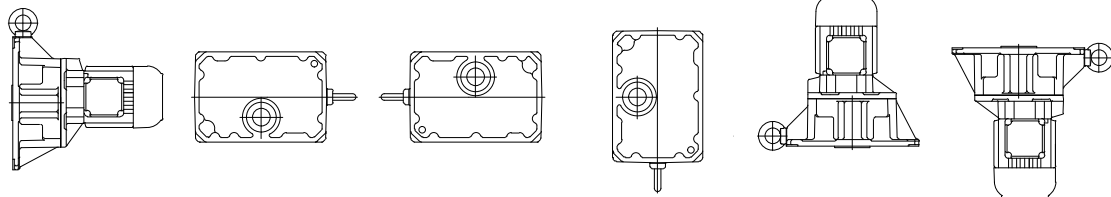

5

	H4	H1	H2	H3	V1	V2
BF	H4	H1	H2	H3	V1	V2
BG						
BK	H1	V1	V2	H2	H4	H3
BS						
Gear type						
BF10Z BF10Z BK10Z BS10Z	0,10	0,05	0,12	0,07	0,16	0,07
BG20Z BF20Z BK20Z BS20Z	0,15	0,07	0,19	0,17	0,27	0,10
BG30Z BF30Z BK30Z BS30Z BM30Z BM30Z	0,2*	0,10	0,35	0,22	0,35	0,19
BG40Z BF40Z BK40Z BS40Z BM40Z	0,32*	0,17	0,50	0,37	0,6	0,32
BG50Z BF50Z BK50Z	0,5	0,3	0,92	0,7	1,15	0,5
BG60Z BF60Z BK60Z	0,9	0,5	1,55	1,1	2,0	0,7
BG70Z BF70Z BK70Z BS70Z	1,2	0,6	1,8	1,6	2,4	1,4
BG80Z BF80Z BK80Z BS80Z	3,1	1,3	4,0	2,6	5,2	2,0
BG90Z BK90Z	4,2	1,5	5,4	3,5	7,7	3,0

\*: with BM30Z/BM40Z the pre-stage lubricant is filled via the main gearbox.

Lubrication quantity in litre



### Lubrication quantity for intermediate gear

#### Definition of the terminal box position

Terminal box position for intermediate gear is similar to the main gearbox that means

Main gearbox BG, BF terminal box pos. I -> intermediate gearbox terminal box pos. I

Main gearbox BK, BS terminal box pos. II -> intermediate gearbox terminal box pos. II

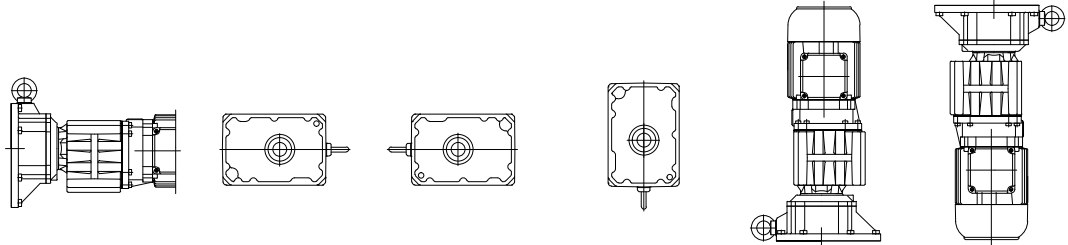

Mounting position of main gearbox	BF	H4	H1	H2	H3	V1	V2
	BG						
	BK	H1	V1	V2	H2	H4	H3
	BS						
Type designation of double gearbox combination							
BG06G04 BK06G04	BS06G04	0,03	0,03	0,03	0,03	0,05	0,05
BG10G06 BK10G06	BF10G06 BS10G06	0,08	0,08	0,08	0,08	0,15	0,15
BG20G06 BK20G06	BF20G06 BS20G06	0,08	0,08	0,08	0,08	0,15	0,15
BG30G06 BK30G06	BF30G06 BS30G06	0,08	0,08	0,08	0,08	0,15	0,15
BG40G10 BK40G10	BF40G10 BS40G10	0,65	0,65	0,65	0,85	1,05	0,85
BG50G10 BK50G10	BF50G10	0,65	0,65	0,65	0,85	1,05	0,85
BG60G20 BK60G20	BF60G20	0,8	0,8	0,8	1,1	1,4	1,1
BG70G20 BK70G20	BF70G20	0,8	0,8	0,8	1,1	1,4	1,1
BG80G40 BK80G40	BF80G40	1,7	1,7	1,7	2,5	3,3	2,1
BG90G50 BK90G50	BF90G50 BG100G50	3,0	3,0	3,0	4,5	5,5	3,3
Lubrication quantity in litre							

# Gearboxes & Lubrication

## Threaded plugs

Position of threaded plugs  
-BG-series gears

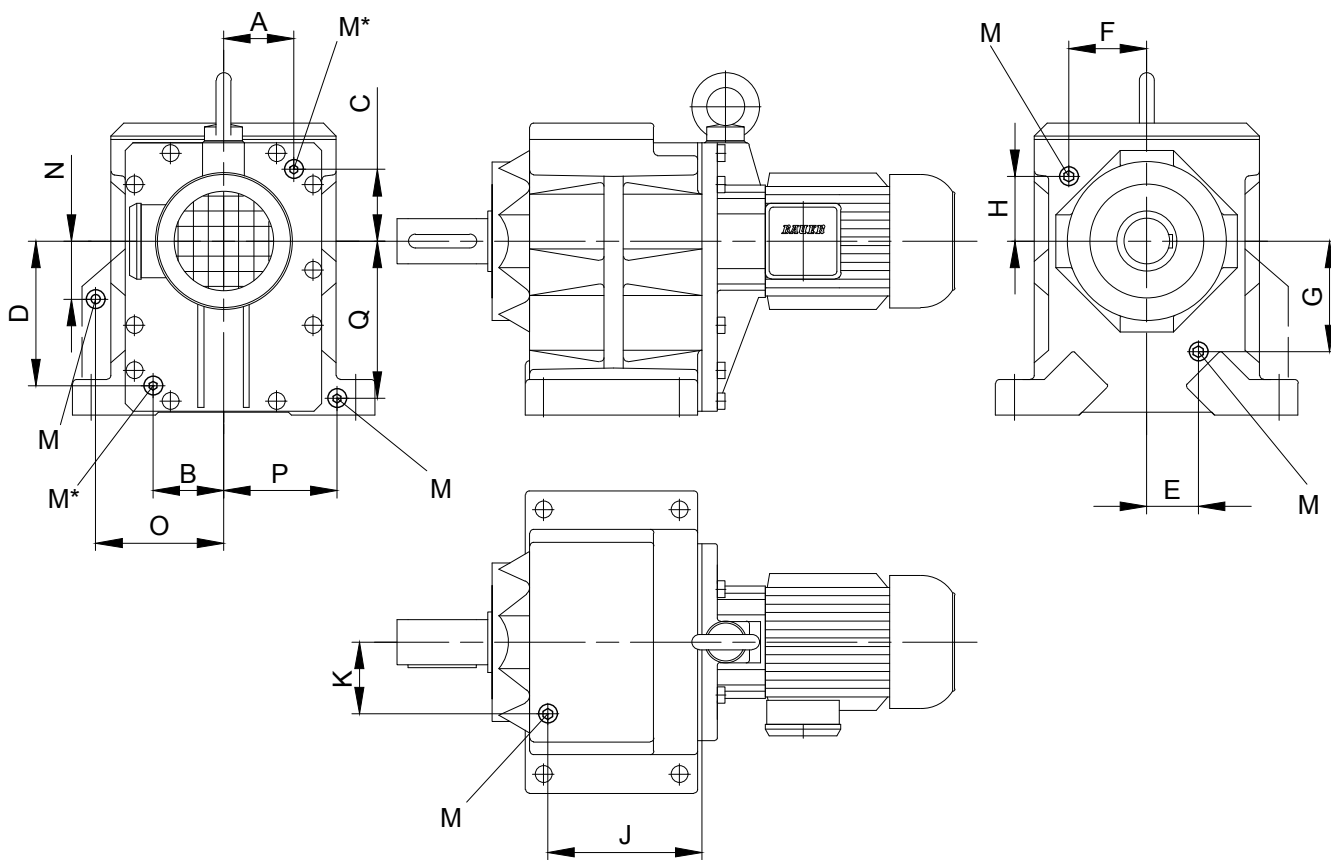

Typ		A	B	C	D	E	F	G	H	J	K	N	O	P	Q	M	
BG10	Foot housing	see position of the oil drain and filler plugs on the system cover	Tab.I-Tab.III size B.10	B.10	33	42	48	41,5	-	-	-	-	-	-	-	M10x1	
BG10	Flange housing		Tab.I-Tab.III size B.10	B.10	27	-	73	-	-	-	-	-	-	-	-	-	M10x1
BG15	Foot housing		Tab.I-Tab.III size B.10	B.10	-	-	-	-	-	-	-	-	-	-	-	-	-
BG20	Foot housing		Tab.I-Tab.III size B.20	B.20	-	47	-	52,5	-	-	-	-	-	-	-	-	M10x1
BG20	Flange housing		Tab.I-Tab.III size B.20	B.20	-	28	-	68	-	-	-	-	-	-	-	-	-
BG30	Foot housing		Tab.I-Tab.III size B.30	B.30	-	54	-	58	-	-	-	-	-	-	-	-	M10x1
BG30	Flange housing		Tab.I-Tab.III size B.30	B.30	-	58	-	48	-	-	-	-	-	-	-	-	M10x1
BG40	Foot housing		Tab.I-Tab.III size B.40	B.40	-	75	-	48	-	-	-	-	-	-	-	-	M14x1,5
BG40	Flange housing		Tab.I-Tab.III size B.40	B.40	-	75	-	48	-	-	-	-	-	-	-	-	M14x1,5
BG50	Foot housing		Tab.I-Tab.III size B.50	B.50	-	53	-	100	-	-	-	-	-	-	-	-	M14x1,5
BG50	Flange housing		Tab.I-Tab.III size B.50	B.50	-	53	-	100	-	-	-	-	-	-	-	-	M14x1,5
BG60	Foot housing		Tab.I-Tab.III size B.60	B.60	-	70	-	119	-	-	-	-	-	-	-	-	M20x1,5
BG60	Flange housing		Tab.I-Tab.III size B.60	B.60	-	70	-	119	-	-	-	-	-	-	-	-	M20x1,5
BG70			Tab.I-Tab.III size B.70	B.70	-	103	-	86	204	95	-	-	-	-	-	-	M20x1,5
BG80			Tab.I-Tab.III size B.80	B.80	-	133	-	110	237	111	-	-	-	-	-	-	M20x1,5
BG90			Tab.I-Tab.III size B.90	B.90	-	165	-	124	297	140	-	-	-	-	-	-	M24x1,5
BG100		Tab.I-Tab.III size B.80	B.80	-	202	-	128	420	165	135	263	202	293			M24x1,5	

M = Plug according to DIN 908

Dimensions in millimetres (mm)

M\* = Size and position of the drain plug see page 76.

**Position of threaded plugs**  
**-BG-20-01R**

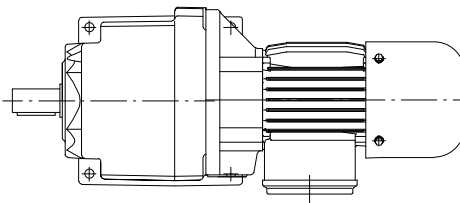
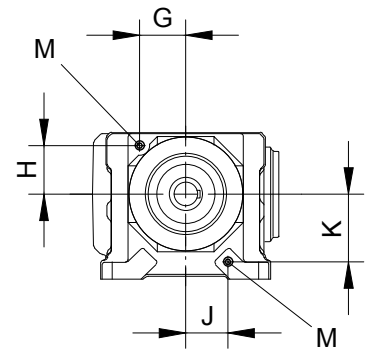
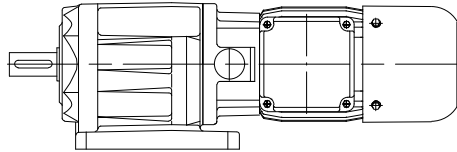
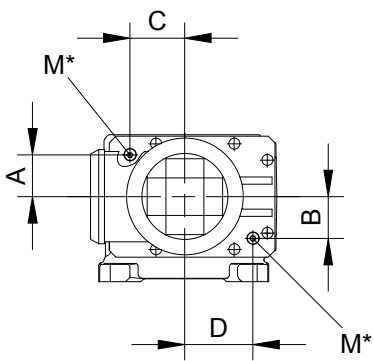

5

Type	A	B	C	D	G	H	J	K	M
BG20-01R Roller table	see position of the oil drain and filler plugs on the system cover Tab.I-Tab.III size B20				48,5	51,5	45	71,5	M10x1
M = Plug according to DIN 908 Dimensions in millimetres (mm)									

M\* = Size and position of the drain plug see page 76.

# Gearboxes & Lubrication

## Threaded plugs

### Position of threaded plugs

-BF-series gears

5

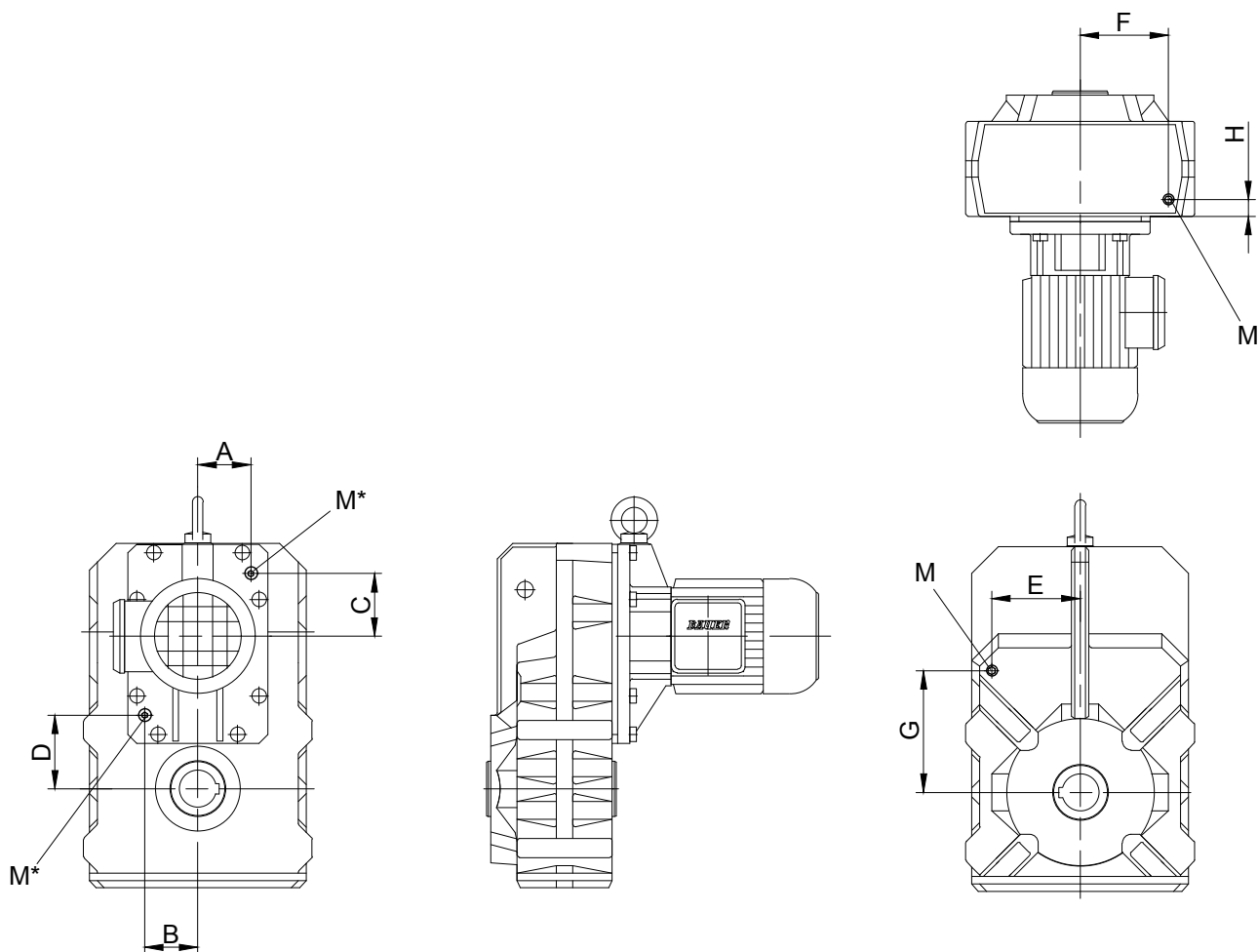

Type	A	B	C	D	E	F	G	H	M
BF06	see position of the oil drain and filler plugs on the system cover	on request							
BF10		Tab.I-Tab.III size	B.10	64	65	97	28	M10x1	
BF20		Tab.I-Tab.III size	B.20	77	70	115	30,5	M10x1	
BF30		Tab.I-Tab.III size	B.30	88	82	125	36,5	M10x1	
BF40		Tab.I-Tab.III size	B.40	100	86	141	33	M14x1,5	
BF50		Tab.I-Tab.III size	B.50	120	105	165	42,3	M14x1,5	
BF60		Tab.I-Tab.III size	B.60	140	145	200	50,5	M20x1,5	
BF70		Tab.I-Tab.III size	B.70	165	177	235	52,5	M20x1,5	
BF80		Tab.I-Tab.III size	B.70	145	148	255	123	M20x1,5	
BF90		Tab.I-Tab.III size	B.80	155	176	347,5	260	M24x1,5	

M = Plug according to DIN 908  
Dimensions in millimetres (mm)

M\* = Size and position of the drain plug see page 76.

### Position of threaded plugs

#### -BK-series gears

BK10 - BK50

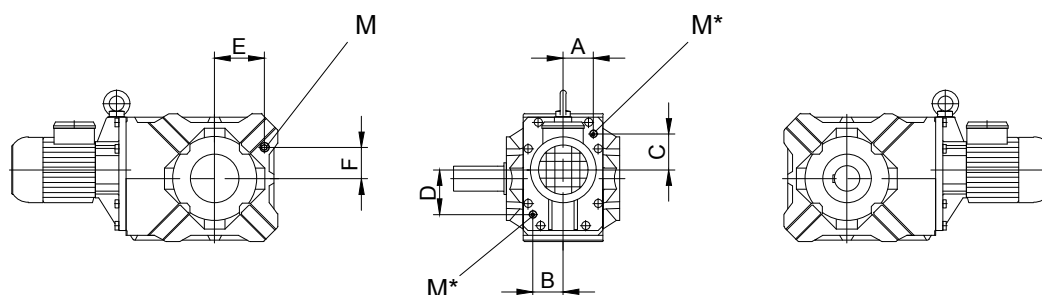

BK60 - BK90

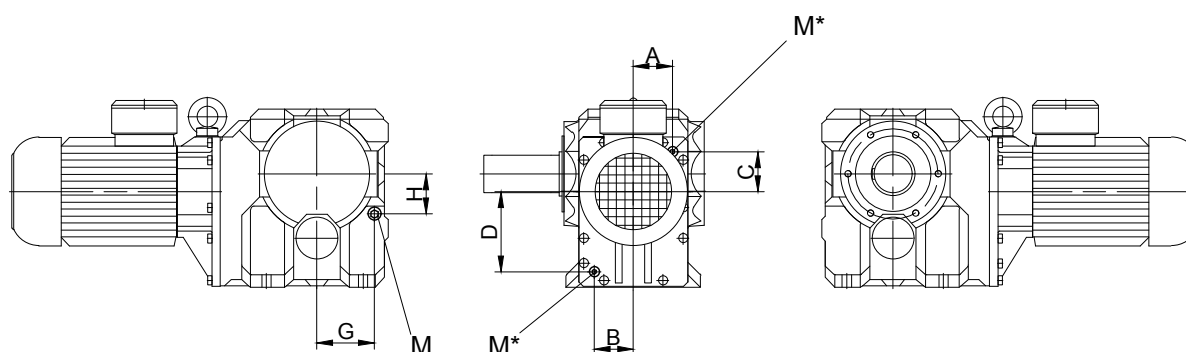

Type	A	B	C	D	E	F	G	H	M
BK06	see position of the oil drain and filler plugs on the system cover	on request							
BK10		Tab.I-Tab.III size B.10	62	32,5	-	-	M10x1		
BK20		Tab.I-Tab.III size B.20	73,5	37,5	-	-	M10x1		
BK30		Tab.I-Tab.III size B.30	80	43	-	-	M10x1		
BK40		Tab.I-Tab.III size B.40	88	49	-	-	M14x1,5		
BK50		Tab.I-Tab.III size B.50	118	74	-	-	M14x1,5		
BK60		Tab.I-Tab.III size B.60	-	-	93	87	M20x1,5		
BK70		Tab.I-Tab.III size B.70	-	-	137	95	M20x1,5		
BK80		Tab.I-Tab.III size B.80	-	-	150	117	M20x1,5		
BK90		Tab.I-Tab.III size B.90	-	-	208	135	M24x1,5		

M = Plug according to DIN 908  
Dimensions in millimetres (mm)

M\* = Size and position of the drain plug see page 76.

# Gearboxes & Lubrication

## Threaded plugs

Position of threaded plugs  
-BS-series gears

BS10 - BS20

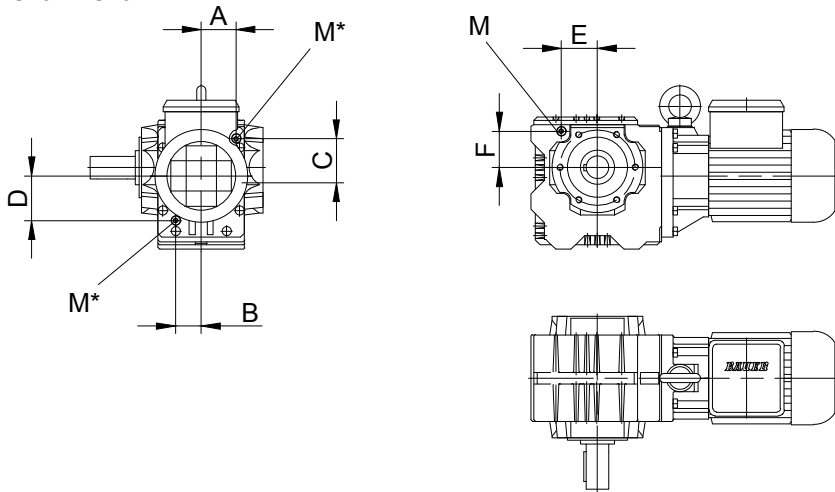

BS30 - BS40

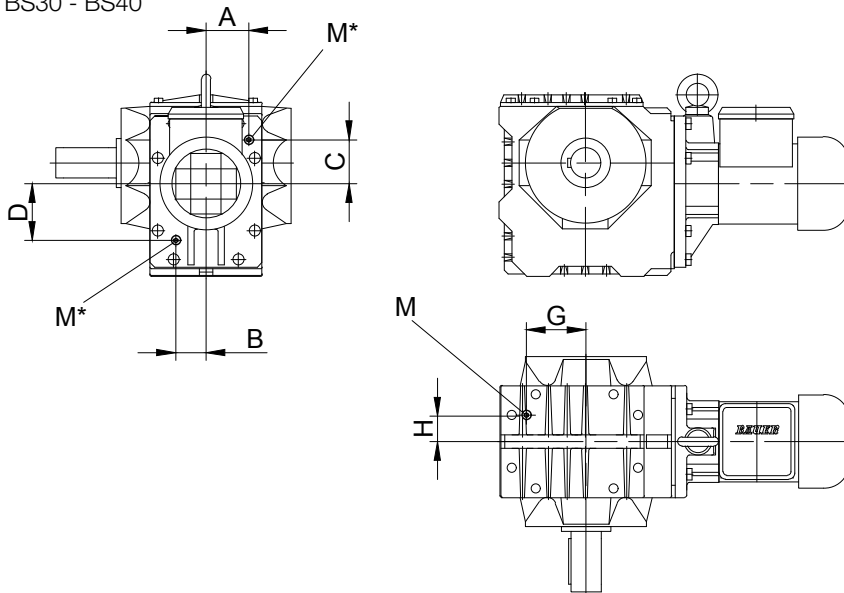

Type	A	B	C	D	E	F	G	H	M
BS10	see position of the oil drain and filler plugs on the system cover	Tab.I-Tab.III size B.10			48	50	-	-	M10x1
BS20		Tab.I-Tab.III size B.20			59	63	-	-	M10x1
BS30		Tab.I-Tab.III size B.30			-	-	79	35	M10x1
BS40		Tab.I-Tab.III size B.40			-	-	93,5	41,5	M14x1,5

M = Plug according to DIN 908  
Dimensions in millimetres (mm)

M\* = Size and position of the drain plug see page 76.

### Position of threaded plugs -pre-stage gears (Z)

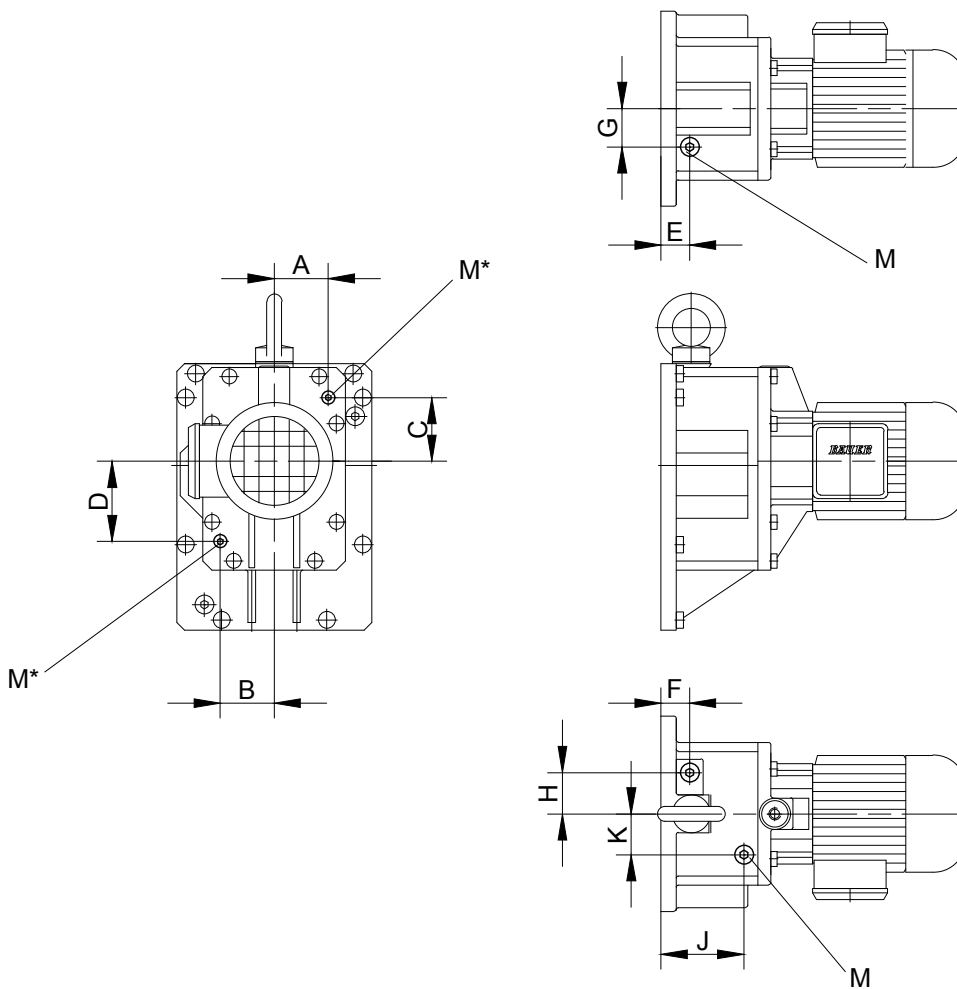

5

Gear	A	B	C	D	E	F	G	H	J	K	M	
BG10(Z);BK10(Z)	-	-	-	-	25	-	17,5	-	44	25	M10x1	
BF10(Z);BS10(Z)	-	-	-	-	49	-	28,5	-	23,5	28	M10x1	
BG20(Z);BK20(Z)	see position of the oil drain and filter plugs on the system cover	Tab.I and Tab.III size B10			-	24	-	30	-	-	M10x1	
BF30(Z);BS30(Z)		Tab.I and Tab.III size B20			-	27,5	-	36,5	-	-	M14x1,5	
BG40(Z);BK40(Z)		Tab.I and Tab.III size B30			-	-	-	-	29	43	M14x1,5	
BF40(Z);BS40(Z)		Tab.I and Tab.III size B40			-	33	-	48	-	-	M20x1,5	
BG50(Z);BK50(Z)		Tab.I and Tab.III size B50			-	38	-	55	-	-	M20x1,5	
BF50(Z)		Tab.I and Tab.III size B60			-	45	-	-	-	-	M20x1,5	
BG60(Z);BK60(Z)		Tab.I and Tab.III size B70			-	-	-	-	-	-	M24x1,5	
BF60(Z)												
BG70(Z);BK70(Z)												
BF70(Z);BF80(Z)												
BG80(Z);BK80(Z)												
BF90(Z);BG100(Z)												
BG90(Z);BK90(Z)												

M = Plug according to DIN 908  
Dimensions in millimetres (mm)

M\* = Size and position of the drain plug see page 76.

# Gearboxes & Lubrication

## Threaded plugs

Position of threaded plugs  
-in the System Cover Design with Standard Geared Motor

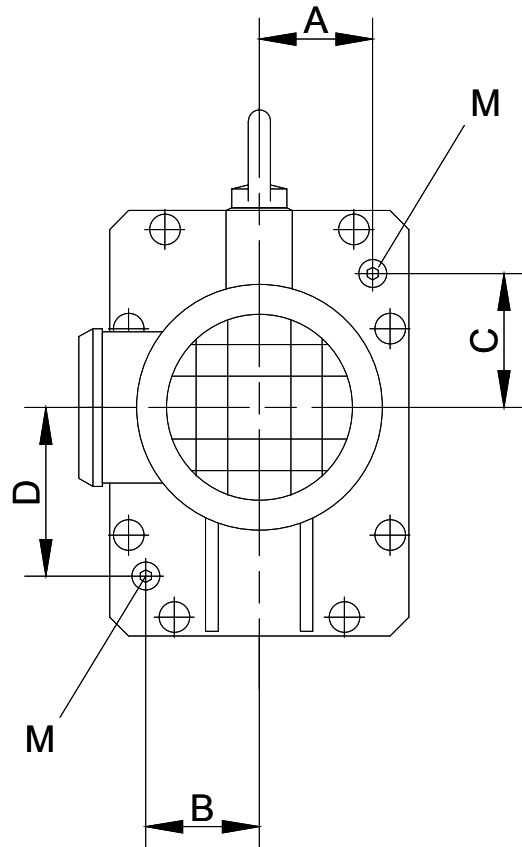

5

Table I: Design with Standard Geared Motor

Gear	Size	A	B	C	D	M
BG10(Z); BK10(Z); BF10(Z);BS10(Z)	D05-D..09	36	34	43,5	59	M10x1
BG15	D05-D..09	36	34	43,5	59	M10x1
BG20(Z); BK20(Z); BF20(Z);BS20(Z)	D05-D..09	44	44	58	72,5	M10x1
BG30(Z); BK30(Z); BF30(Z);BS30(Z)	D05-D..09	56,5	40	58,2	75	M10x1
BG40(Z); BK40(Z); BF40(Z);BS40(Z)	D..08-D..11	66	71	71	94	M14x1,5
BG50(Z); BK50(Z); BF50(Z);	D..08-D..11	72	74	85	109	M14x1,5
BG60(Z); BK60(Z); BF60(Z);	D..13-D..16	78	74	82	109	M14x1,5
BG60(Z); BK60(Z); BF60(Z);	D..09-D..13	84	81	120	155	M20x1,5
BG70(Z); BK70(Z); BF70(Z);BF80(Z)	D..16	86	81	120	155	M20x1,5
BG70(Z); BK70(Z); BF70(Z);BF80(Z)	D..09-D..18	95	85	97	193	M20x1,5
BG80(Z); BK80(Z); BF90(Z);BG100(Z)	D..11-D..18	118	118	110	245	M20x1,5
BG90(Z); BK90(Z);	D..13-D..18	145	145	116	294	M24x1,5

M = Plug according to DIN 908  
Dimensions in millimetres (mm)

Position of the drain plugs for BG, BK, BS and BF gear ranges and pre-stages.



**Position of threaded plugs**  
**-in the System Cover Design with foreign motor or gear design with input shaft**

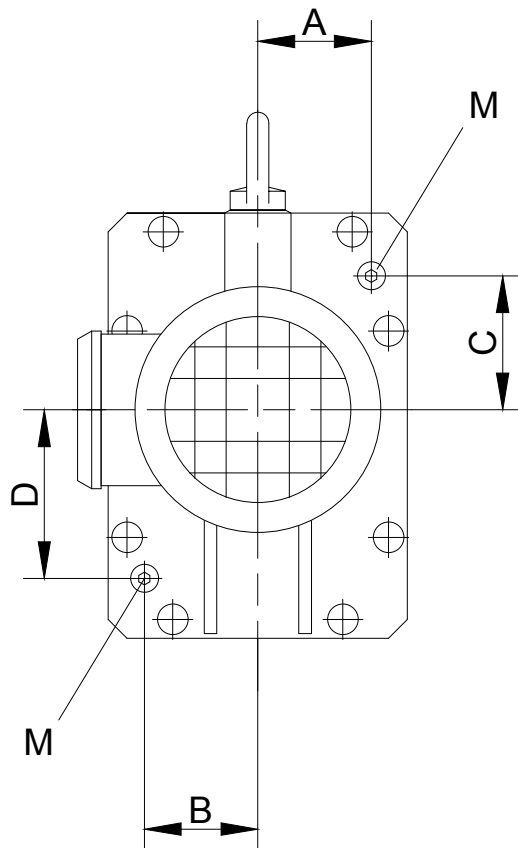

Table II: Design with foreign motor or gear design with input shaft

Gear	A	B	C	D	M
BG10(Z); BK10(Z); BF10(Z);BS10(Z)	1,34	1,34	1,59	2,24	M10x1
BG15	1,34	1,34	1,59	2,24	M10x1
BG20(Z); BK20(Z); BF20(Z);BS20(Z)	1,73	1,73	2,24	2,83	M10x1
BG30(Z); BK30(Z); BF30(Z);BS30(Z)	2,30	1,61	2,27	3,03	M10x1
BG40(Z); BK40(Z); BF40(Z);BS40(Z)	2,72	2,87	2,76	3,82	M14x1,5
BG50(Z); BK50(Z); BF50(Z);	2,95	2,95	3,23	4,33	M14x1,5
BG60(Z); BK60(Z); BF60(Z);	3,31	3,19	4,69	6,10	M20x1,5
BG70(Z); BK70(Z); BF70(Z);BF80(Z)	3,78	3,74	3,78	7,60	M20x1,5
BG80(Z); BK80(Z); BF90(Z);BG100(Z)	4,65	4,65	4,33	9,65	M20x1,5
BG90(Z); BK90(Z);	5,71	5,71	4,57	11,57	M24x1,5
M = Plug according to DIN 908 Dimensions in millimetres (mm)					

Position of the drain plugs for BG, BK, BS and BF gear ranges and pre-stages.

