



DYNAPAR™ Encoder Installation Manual

Dynapar™ brand

SERIES HS35R

Sealed Hollowshaft Encoder

Document No.: 702761-0001

Revision Level: E

May 6, 2010



DESCRIPTION

The Series HS35R Sealed Hollowshaft encoder is equipped with an unbreakable disk that handles the most severe shock and vibration. Its hollow shaft mount and anti-rotation tether reduce bearing wear and maintenance. Series HS35R has electrical protection from overvoltage, reverse voltage, and output short circuits when ordered with standard operating temperature configuration.

Series HS35R is not only electrically & thermally isolated (for shaft sizes 1.125" and under) but also environmentally sealed with shaft seals at both ends.

KEY FEATURES

- **Phased Array Sensor for Reliable Signal Output**
- **Rugged Design Withstands up to 400g Shock**
- **Unbreakable Code Disc up to 5000PPR**
- **Improved Seal Design for Increased Moisture Resistance**

IMPORTANT INSTALLATION INFORMATION

Mounting the Encoder: Before Installation, ensure power is disconnected from encoder and motor or machine.

CAUTION: *The loads applied to the encoder shaft must be in accordance with the specifications of this device.*

Important Wiring Instructions: Use of shielded cable is recommended for all encoder installations. The shield should be connected to signal-ground at the receiving device only.

Grounding: For applications with high ground potential differences, DO NOT ground the encoder through both machine and controls end. Connect the shield at the controls end only. NOTE: If the shield is connected at both ends, grounding problems that degrade system performance can result.

CE Grounding Measures – For best EMC immunity the cable screen must be grounded on both encoder and controls end. For cable lengths longer than 30m or outdoor applications, additional measures must be implemented to comply with CE requirements. Connection of the encoder to DC power supply network is prohibited if CE compliance is required. CE-compliant products are tested to EN61326-1 EMC.

In all cases, system CE compliance is ultimately the responsibility of the manufacturer integrating the encoder.

Connecting the shield at both ends can cause grounding problems that degrade system performance.

If possible, run the encoder cable through a dedicated conduit (not shared with other wiring). Use of conduit will protect the cable from physical damage and provide a degree of electrical isolation. Do not run the cable in close proximity to other conductors that carry current to heavy loads such as motors, motor starters, contactors, solenoids, etc. This practice can induce electrical transients in the encoder cable, potentially interfering with reliable data transmission.

Refer to Electrical Connections table for wiring information. To avoid possible damage, do not connect or disconnect the encoder connector or wiring while power is applied to the system.

CAUTION: *Unused encoder signal wires must be individually insulated and under no circumstances be in contact with ground, voltage sources, or other signal lines.*

MECHANICAL INSTALLATION

A. GENERAL OVERVIEW

The following instructions are meant to assist in proper installation of Dynapar brand, Series HS35R hollowshaft encoders. The encoder is a speed and position transducer that when mounted to a rotating shaft, produces output pulses that are directly proportional to the shaft speed and direction. The hollowshaft encoder is attached to the motor shaft by using a clamp down collar. The HS35R can accommodate several machine shaft diameters by selecting the appropriate bore size. During installation, certain physical properties associated with the mechanical coupling must be observed to ensure a long operation life of the encoder.

B. SHAFT EXTENSION

Solid shaft preferred, keyway allowed; flatted shaft must not be used. The minimum shaft engagement length that will allow support to encoder housing is 1.25", Shaft engagement length of 1.60" (40.6mm) or longer is recommended for reduced wobble. The longest shaft length as measured from the mounting face that will allow installation of the shaft cover is 2.60" (66 mm) maximum. Installations that employ a press-fit or screwed-on stub shaft adapter should align the stub shaft to 0.002" TIR or less with a dial indicator

C. TETHER POINT

For general industrial machinery and C-face motor installations, locate the tether hole at the nominal bolt circle location. The tether holes are slightly elongated, to allow for hole location tolerance and arcing of the tether, if the hole location is not flush with the tether surface.

HOLE LOCATION	BOLT SIZE	BOLT SIZE	RECOMMENDED TORQUE
2.94"(75 mm)	3/8"(9.5 mm)	1/4"(6mm)	50-60 in-lbs
3.63" (92 mm)	1/2" (12 mm)	5/16"(8mm)	70-80in-lbs
2.5"-3.25" (63-82mm)	1/4" (6 mm)	3/8"(9.5mm)	100-125 in-lbs
		1/2"(12mm)	125-150 in-lbs

STEP 1: PREPARATION AND RECOMMENDED TOOLS

Disconnect power from equipment and encoder cable. Ensure that you have the proper tools. Typical tools that may be needed depending on the options chosen are:

- #2 Phillips Screwdriver; 5/32" Hex Wrench(US); Caliper Gauge; Dial Indicator Gauge; 3/8", 1/2" or 1/4" T- handle Wrenches (tether options); Dynapar M100 encoder tester.

STEP 2: CHECK AND CLEAN THE MATING SHAFT

Ensure that the mating shaft is within proper tolerances. Recommended mating shaft diameter tolerances should be nominal +0.0000"/-0.0005" [0.00 to -0.13mm] and shaft runout TIR should be under 0.002".

Clean the mating shaft of any burrs and check that mating shaft engagement is at least 1.25" inside the encoder shaft. Using a dial indicator gauge verify that the motor shaft Total Indicated Reading (TIR) is less than 0.002" [0.05 mm].

STEP 3: INSTALL ENDCAP

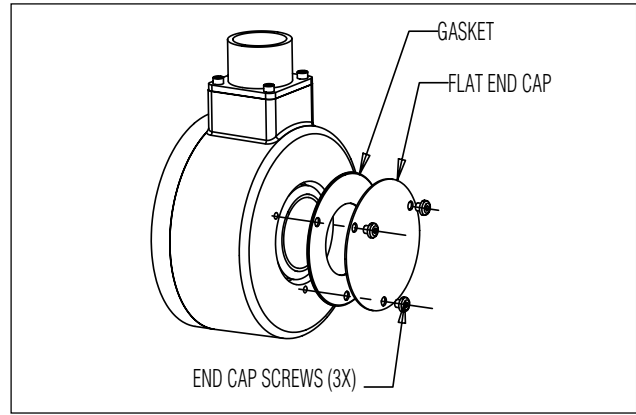

The encoder ships with an endcap to cover the back end of the encoder body, and although optional, is recommended for additional environmental protection. To install, remove the factory installed three screws at the back of the encoder, properly discard the removed back plate and the three screws. Unpack the endcap, gasket and the three screws from the factory supplied kit. Align the three holes and fasten the gasket and end cap to the encoder body as shown.

STEP 4: INSTALL THE TETHER ON ENCODER

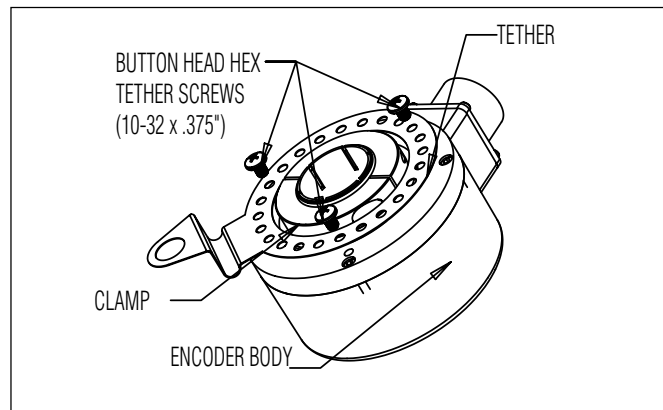

Rotate the tether to the required orientation and tighten the tether arm to the encoder body using the three screws provided. The hollowshaft series encoder tethers can be rotated in 15 degree increments so that connector or cable exit can be conveniently located.

STEP 5: INSTALL WASHERS ON TETHER

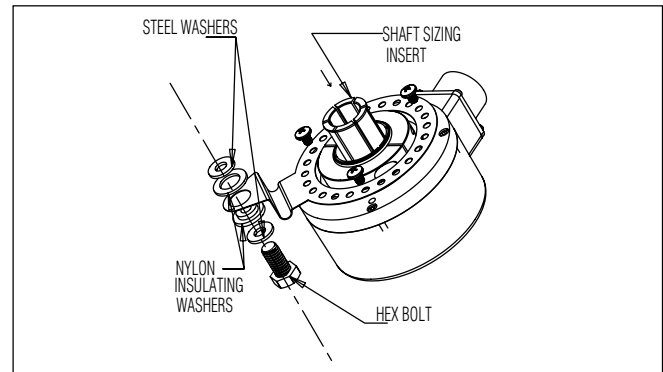

Slide the flat nylon washer on the side away from the bend and the flanged nylon washer on the side of the bend and press them together until they are fully seated in the tether hole. One steel washer is to be used on each side of the nylon washer.

STEP 6: SLIDE ENCODER ON SHAFT

Carefully slide the encoder all the way down until the tether rests on the motor face without any stress on the tether. Do not tighten the shaft clamp on the encoder yet

STEP 7A: SECURE TETHER TO MOUNTING FACE (MOTOR MOUNT)

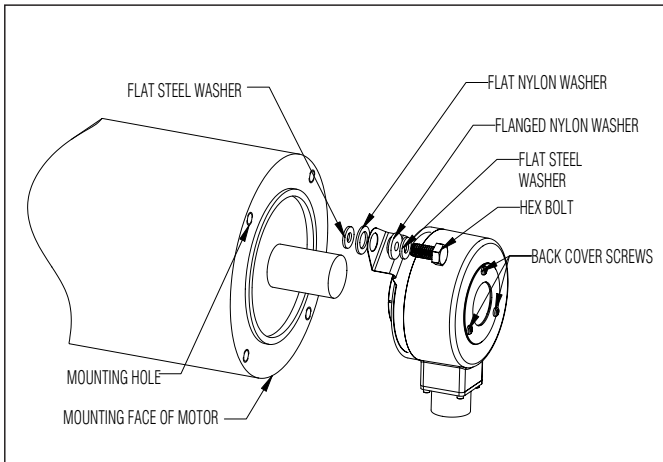

Rotate the tether arm until it is at the correct orientation and is aligned with the mounting holes on the the motor or equipment. Install one steel washer on both sides of the nylon washer. Refer figure above. Fasten the tether arm to the motor or machine housing using the supplied 3/8" bolt (4.5" C-face applications) or 1/2" bolt (8.5" C-face applications). Ensure that there is no stress or flexing of the tether arm when secured.

STEP 7B: SECURE TETHER TO MOUNTING FACE (FAN COVER MOUNT)

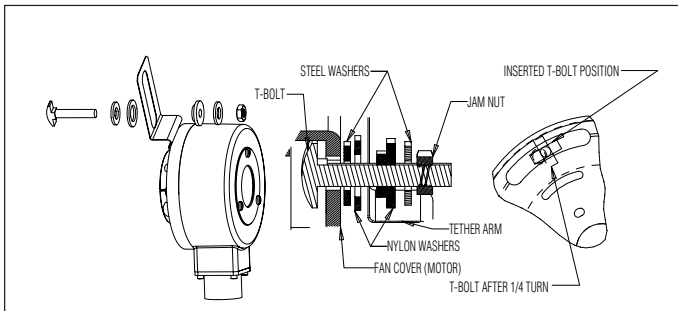

Slide and insert the T-bolt as shown in the figure into the fan cover. Use the supplied insulating hardware and washers as shown. Tighten the jamnut to firmly secure the tether.

STEP 8: TIGHTEN ENCODER CLAMP ONTO MATING SHAFT

Check to make sure that the tether is still in its "unstressed" condition. Adjust position of encoder on shaft if necessary and then tighten the shaft clamp on the encoder. Tighten clamp to stated torque value provided on encoder datasheet (50-55 in-lbs.).

NOTE: ENCODER MODELS WITH SPLIT CLAMPS HAVE TWO SCREWS TO TIGHTEN DOWN. PLEASE ENSURE THAT BOTH SCREWS ON THE CLAMP ARE TIGHTENED DOWN SECURELY. YOU MAY HAVE TO ROTATE THE SHAFT TO TIGHTEN BOTH SCREWS DOWN.

STEP 9: GOOD INSTALLATION CHECK POINT

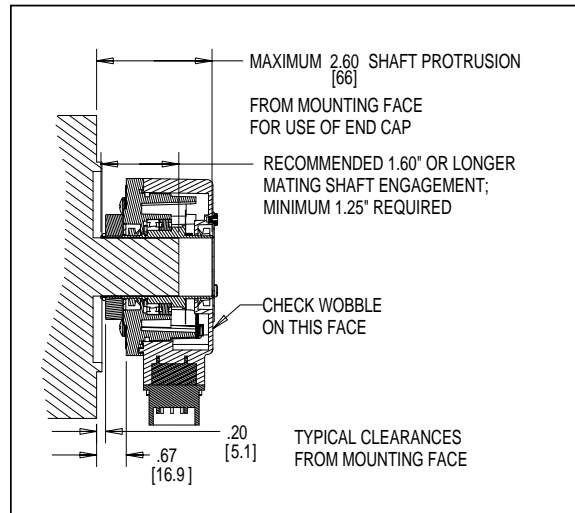

Follow the 3 step installation check to ensure a good installation thus far. Refer to figure above for key reference dimensions

A. Check clearances from mounting face. Ensure you have a minimum clearance of 1/16" between the encoder shaft and any non-rotating surface closest to the encoder shaft

B. Check tether installation. Make sure that the tether is unstressed. There should be no visible bending or deflection on any surface of the tether. Visible tether deflections should be corrected immediately. If the tether is bent or distorted, DO NOT USE, and call the factory for a replacement tether. Tether installation is critical to the long life of the bearings and improper tether installation will lead to excessive bearing loads and encoder failure.

C. Check wobble of encoder housing. Turn the shaft by hand and make sure that the shaft turns freely and does not produce excessive runout/wobble of the encoder. Most encoder installations will have wobble arising from shaft tolerances. Measure the wobble on the visible back face of the encoder. A wobble of less than 0.007" TIR will not have any adverse effect on encoder performance. In general, the lower the TIR of runout, the better.

STEP 10: BASKET GUARD INSTALLATION (optional)

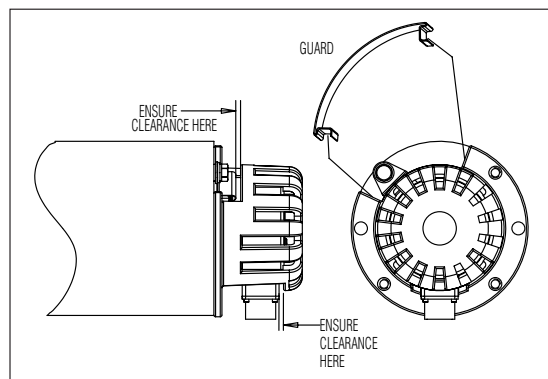

After installation of the encoder place the accessory cover over the encoder with the large opening over the connector or cable and shorter opening positioned over the tether. Ensure the cover is fully seated on the motor face and secure with bolts and washers provided. When mounting to a fan cover instead of a 56C face cover, center cover and drill 3 mounting holes(.17") in diameter. Then use the 3 #10-24 self tapping screws and washers provided. Install the warning label in the most conspicuous position. Snap guard is to be used as shown (use if required).

SPECIFICATIONS

STANDARD OPERATING CHARACTERISTICS

Code: Incremental
Resolution: to 5000 PPR (pulses/revolution) See Ordering Information

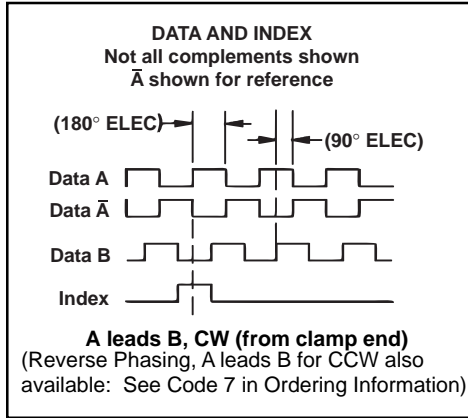

Format: Two channel quadrature (AB) with optional Index (Z), and complementary outputs
Phase Sense: A leads B for CW shaft rotation viewing the shaft clamp end of the encoder
Quadrature Phasing: For resolutions to 1200 PPR: 90° ± 15° electrical; For resolutions over 1250 PPR: 90° ± 30° electrical
Symmetry:
 For resolutions to 1024PPR: 180° ± 18° electrical
 For resolutions over 1024PPR: 180° ± 25° electrical
Waveforms: Squarewave with rise and fall times less than 1 microsecond into a load capacitance of 1000 pf

ELECTRICAL

Input Power: 5-26VDC, 5-15VDC. 50 mA max., not including output loads.
Outputs: ET7272, ET7273, 4469
Frequency Response: 125 kHz (data & index)
Termination: MS Connector; M12 Connector; cable exit w/ seal. See Ordering Information
Noise Immunity: Tested to EN61326-1 EMC
Mating Connector:
 6 pin MS, style MS3106A-14S-6S (MCN-N4)
 7 pin MS, style MS3106A-16S-1S (MCN-N5)
 10 pin MS, style MS3106A-18-1S (MCN-N6)
 10 pin Bayonet, MS3116-F12-10S (607545-0001)
 Cable w/ 5 pin M12 connector, p/n 112859-xxx Cable w/ 8 pin M12 connector, p/n 112860-xxx

ELECTRICAL CONNECTIONS

6, 7 & 10 Pin MS Connectors and Cables - Code 6 = 0 to 9, A to G

Connector & mate/accessory cable assembly pin numbers and wire color information is provided here for reference. Models with direct cable exit carry the same color coding as shown for each output configuration.

Encoder Function	Cable #108594-* 6 Pin Single Ended		Cable #112123-* 6 Pin Dif Line Drv w/o Id x		Cable #108596-* 7 Pin Dif Line Drv w/o Id x		Cable #108595-* 7 Pin (If Used)		Cable #1400635- or 109209- (NEMA4) 10 Pin Dif Line Drv w/ldx (If Used)		Cable #108615-* 12 Pin CCW (If Used)		Cable # 114448-* 10Pin Bayonet	
	Pin	Wire Color	Pin	Wire Color	Pin	Wire Color	Pin	Wire Color	Pin	Wire Color	Pin	Wire Color	Pin	Wire Color
Sig. A	F	BRN	E	BRN	A	BRN	A	BRN	A	BRN	5	BRN	A	BRN
Sig. B	D	ORN	D	ORN	B	ORN	B	ORN	B	ORN	8	ORN	B	ORN
Sig. Z	C	YEL	—	—	—	—	C	YEL	C	YEL	3	YEL	C	YEL
Power +V	B	RED	B	RED	D	RED	D	RED	D	RED	12	RED	D	RED
N/C	F	—	—	—	—	—	E	—	E	—	7	—	E	—
Com	A	BLK	A	BLK	F	BLK	F	BLK	F	BLK	10	BLK	F	BLK
Case	—	—	—	—	G	GRN	G	GRN	G	GRN	9	—	G	GRN
Sig. A	—	—	C	BRN/WHT	C	BRN/WHT	—	—	H	BRN/WHT	6	BRN/WHT	H	BRN/WHT
Sig. B	—	—	F	ORN/WHT	E	ORN/WHT	—	—	I	ORN/WHT	1	ORN/WHT	J	ORN/WHT
Sig. Z	—	—	—	—	—	—	—	—	J	YEL/WHT	4	YEL/WHT	K	YEL/WHT
0V Sense	—	—	—	—	—	—	—	—	—	—	2	GRN	—	—
5V Sense	—	—	—	—	—	—	—	—	—	—	11	BLK/WHT	—	—

MECHANICAL

Shaft Material: 6061-T6 Aluminum
Bore Diameter: 6mm to 28mm, 1.4" to 1.25", electrically isolated
Mating Shaft Length: 1.25", Minimum, 1.60", Recommended
Shaft Speed: 6000 RPM, Maximum (Enclosure Rating is IP64 at speed over 5000 RPM)
Starting torque: 8.0 in-oz. maximum (at 25°C)
Running torque: 5.0 in-oz. maximum (at ambient)
Bearings: ABEC 1
Housing and cover: Hard Anodized and Powder Coated Aluminum
Disc material: Plastic or metal (unbreakable)
Weight: 1.76lb (28 Oz) Typical

ENVIRONMENTAL

Standard Operating Temperature: -40 to +85°C (0 to +70°C with 4469 line driver, see "Ordering Information"). At shaft speed above 3000 RPM, derate 10°C per 1000 RPM
Extended Temperature Range: -40 to +100°C (See ordering information)
Storage temperature: -40 to +100°C
Shock: 400g, 6mSec
Vibration: 5 to 3000 Hz, 20g
Humidity: 100%
Enclosure Rating: IP67 (IP64 at shaft speed above 5000 RPM)

5 & 8 Pin M12 Accessory Cables when Code 6 = H or J

Connector pin numbers and cable assembly wire color information is provided here for reference.

Encoder Function	Cable # 112859- 5 Pin Single Ended		Cable # 112860- 8 Pin Single Ended		Cable # 112860- 8Pin Differential	
	Pin	Wire Color	Pin	Wire Color	Pin	Wire Color
Sig. A	4	BLK	1	BRN	1	BRN
Sig. B	2	WHT	4	ORG	4	ORG
†Sig. Z	5	GRY	6	YEL	6	YEL
Power +V	1	BRN	2	RED	2	RED
Com	3	BLU	7	BLK	7	BLK
Sig. A-bar	—	—	—	—	3	BRN/WHT
Sig. B-bar	—	—	—	—	5	ORG/WHT
†Sig. Z-bar	—	—	—	—	8	YEL/WHT

† Index not provided on all models. See ordering information

Cable Configuration: PVC jacket, 105 °C rated, overall foil shield; 24 AWG conductors, minimum

DIMENSIONS ^{inch}
[mm]

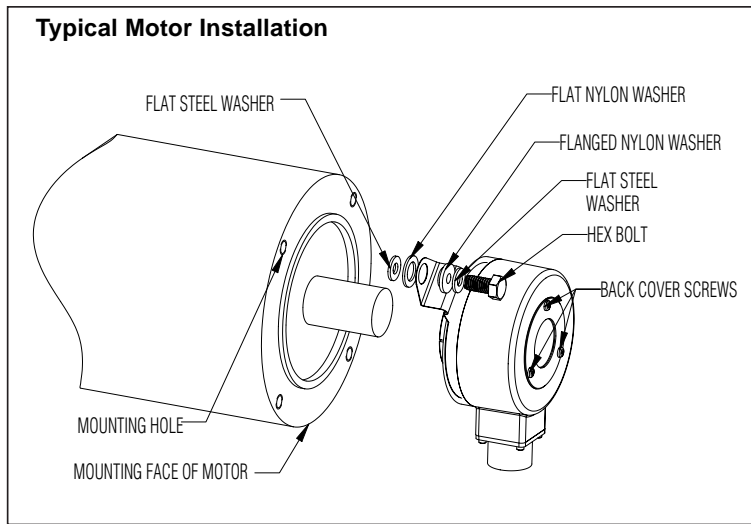
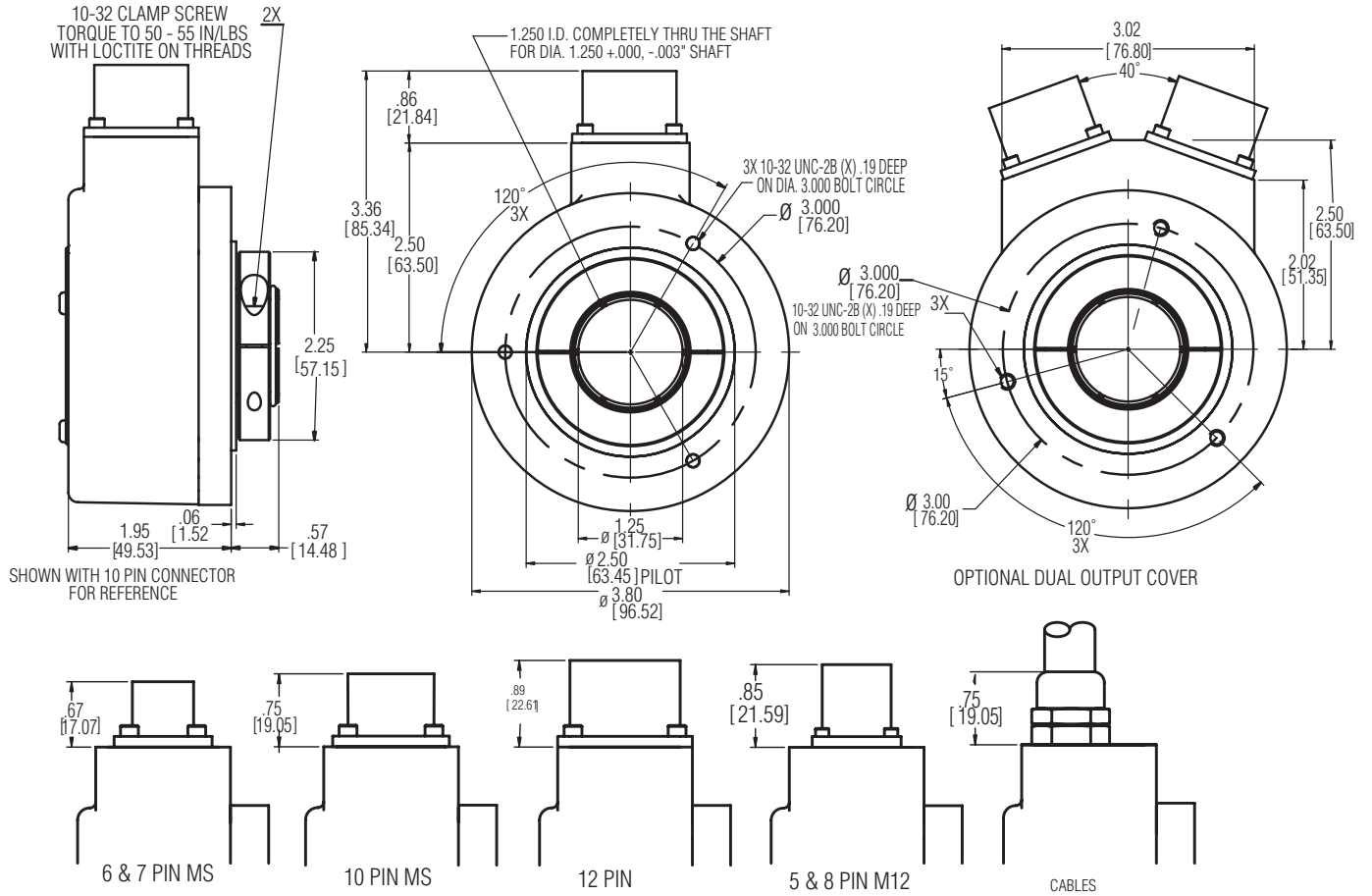

DIMENSIONS ^{inch}
[mm]

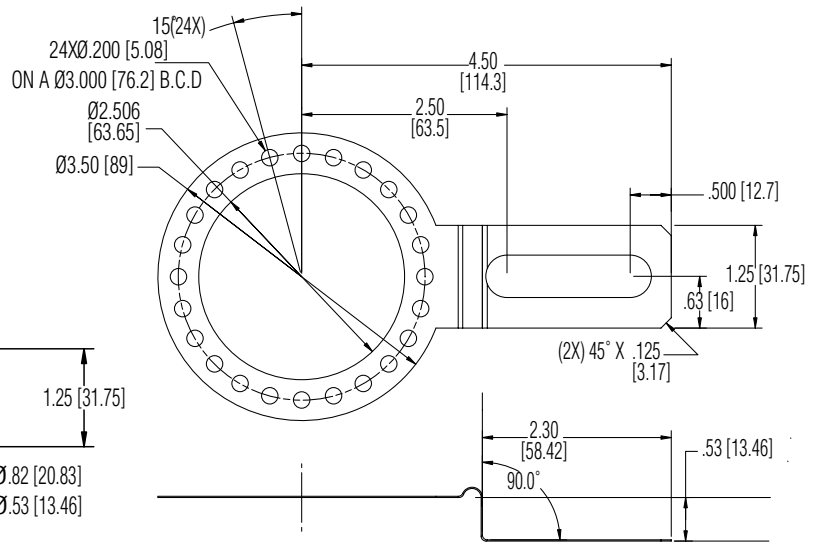
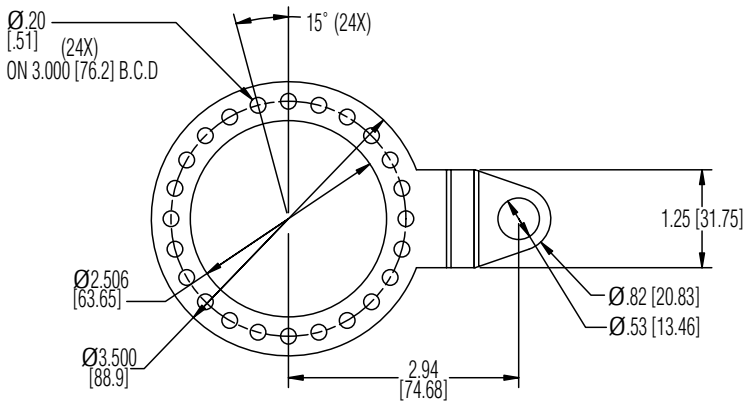

114574-0001 Slotted Tether Kit

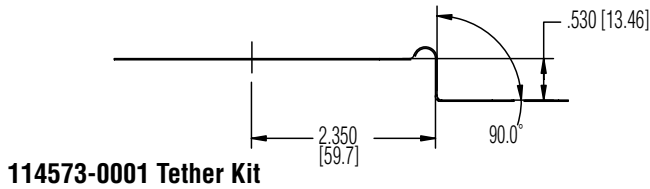

114573-0001 Tether Kit

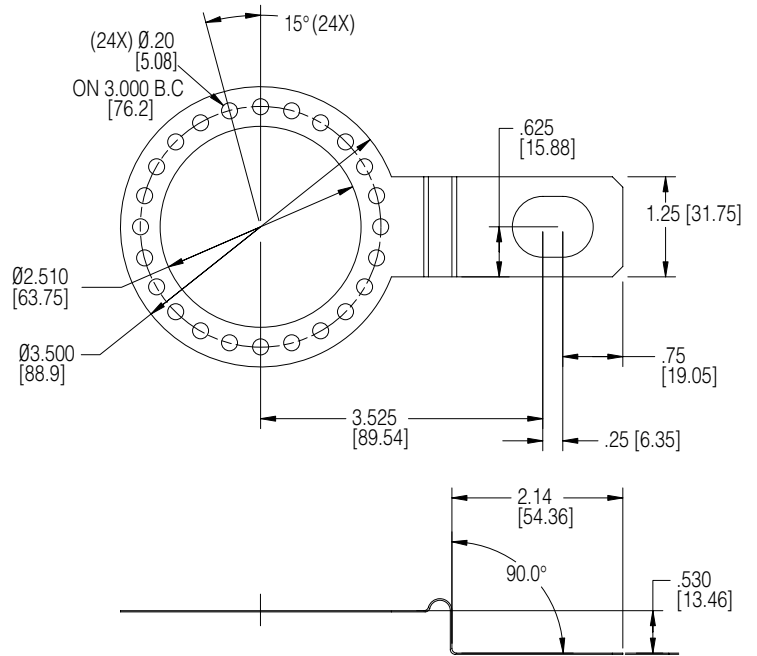

114575-0001 Tether Kit

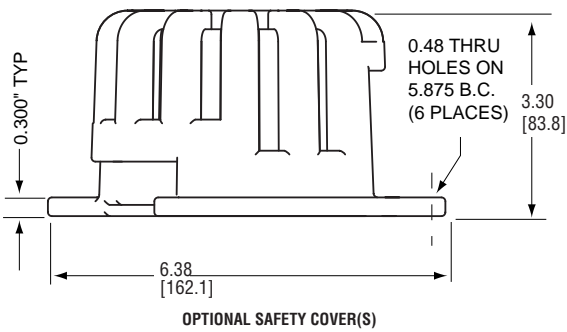

LED OUTPUT OPTION

Dynapar Exclusive: The LED Output Indicator Option makes Dynapar brand the only encoders that show they are installed and operating correctly.

Green light emitting diodes (LEDs) are connected to the signal outputs of the encoder. Set to turn on when the output voltage falls below 2 volts, the LEDs will alternate as the encoder shaft is rotated. For models with differential, or complimentary outputs, a green LED is connected to the non-inverting output and a red LED is connected to the inverting output. In this case, the LED will alternate green-red as the non-inverting output, then the inverting output alternately pulse.

A visual indication of the status of the Index output - also called the Reference, Zero or Marker pulse - makes alignment of the electrical output to a physical point on the machine or process much easier. The encoder shaft is simply rotated until the Index LED turns on, then the shaft coupling is tightened to keep the encoder aligned with the mechanics.

Constant green or red LEDs indicate the corresponding output is permanently grounded, whereas no (green or red) indicating shows that an output is tied to the power supply. Yellow indications occur when both the green and red LEDs turn on at the same time, pointing to a grounded signal at the output that fails to turn off.

The LED Output Indicator Option is packaged in a sealed extruded aluminum housing, providing a rugged, washdown rated and high noise immunity feature that does not derate the encoder performance. Current draw is only 0.5 mA per channel, and the circuitry works with all electrical output configurations.

SPECIFICATIONS

Note: The following LED option specifications may supercede standard encoder specifications

LED Characteristics: On when output signal is < 2 VDC Input

Power: 5 to 26 VDC at 0.5mA per channel; 0.5mA max for unidirectional, 1.0mA max for bidirectional, 1.5mA max for bidirectional with Index

Electrical Protection: Over-voltage, reverse voltage and short-circuit protected

Noise Immunity: Tested to IEC801 level 3 for Electro Static Discharge, Radio Frequency Interference and Electrical Fast Transients

Standard Operating Temperature: -40 to +85°C (0 to +70°C with 4469 line driver, see "Ordering Information"). At shaft speed above 3000 RPM, derate 10°C per 1000 RPM

Extended Temperature Range: -40 to +100°C (See ordering information)

Storage temperature: -40 to +100°C

Shock: 50 G's for 11 milliseconds duration

Vibration: 5 to 2000 Hz @ 20 G's

Humidity: to 98% without condensation

Enclosure Rating: NEMA12 / IP54 standard; NEMA4 / IP66 when ordered with shaft seal

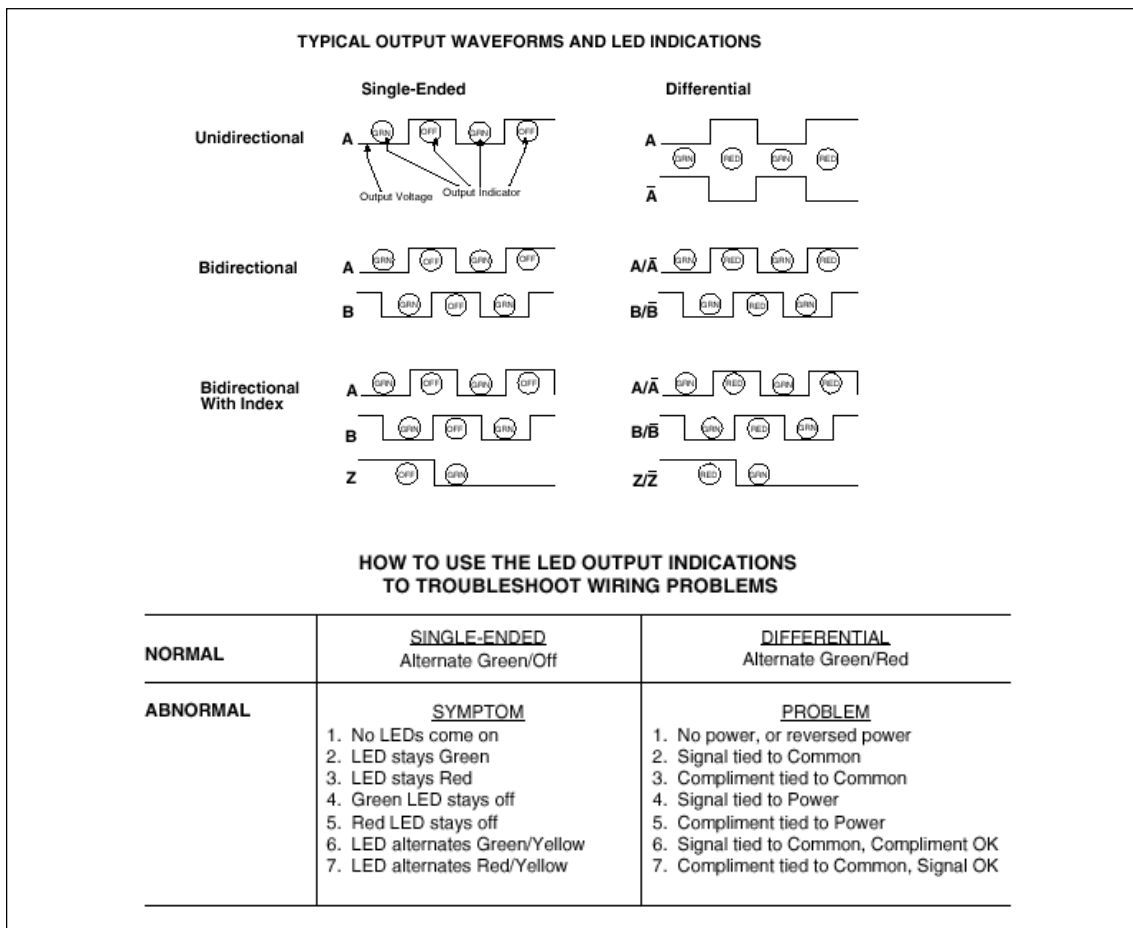

ORDERING INFORMATION

Code 1: Model	Code 2: PPR	Code 3: Bore Size	Code 4: Fixing	Code 5: Output Format	Code 6: Termination	Code 7: Options
HS35R	<input type="checkbox"/> <input type="checkbox"/> <input type="checkbox"/> <input type="checkbox"/>	<input type="checkbox"/>	<input type="checkbox"/>	<input type="checkbox"/>	<input type="checkbox"/>	<input type="checkbox"/> <input type="checkbox"/>
Ordering Information						
HS35R Industrial-duty, hollowshaft encoder	0001 0500	0 6mm	0 None	0 ABZ, 5-26VDC push-pull	0 6 pin	01 Reverse Phasing (A leads B, CCW) Not available when Code 6 is 3, 8, A through J or when Code 5 is 4, 5, 6, 7, 8, 9, A, C, D, E, F, G, L, M, N, P, Q, R and Code 6 is 0 or 5 PS LED Output
	0003 0512	1 1/4"	1 4.5" C-face tether	1 ABZ, 5-26VDC O/C	1 7 pin	
	0010 0600	2 5/16"	2 8.5" C-face tether	2 ABZ, 5-26VDC O/C w/2.2kOhm	2 10 pin	
	0012 0900	3 8mm	3 Slotted tether (to fit standard AC motor fan cover)	H Same as "0" with Extended temp range	3 12 pin	
	0015 1000	4 3/8"	Not available when Code 5 is D, E, F, G, Q, R	J Same as "1" with Extended temp range	4 10 pin bayonet	
	0032 1024	5 10mm		K Same as "2" with Extended temp range	5 6 pin+mating	
	0050 1200	6 12mm	Not available when Code 5 is 0 through C or H through P	4 Differential AB only, 5-26VDC, 5-26VDC out (7272)	6 7 pin+mating	
	0060 1500	7 1/2"		5 Differential AB only, 5-26VDC in, 5VDC out (7272)	7 10 pin+mating	
	0100 2000	8 5/8"	Not available when Code 6 is 0, 1, 5, 6, or H	A Differential AB only, 5-26VDC in, 5VDC out (4469)	8 12 pin+mating	
	0120 2048	9 15mm		C Differential AB only, 5-15VDC in, 5-15VDC out (4469)	9 10pin bayonet+mating	
	0200 2400	A 16mm	Not available when Code 6 is 0, 1, 5, 6, or H	L Same as "4" with Extended temp range	A 0.5m (18") cable	
	0240 2500	C 19mm		M Same as "5" with Extended temp range	C 1m (36") cable	
	0250 3072	D 3/4"	Not available when Code 6 is 0, 1, 5, 6, or H	6 Differential ABZ, 5-26VDC in, 5VDC out (7272)	D 2m (72") cable	
	0300 4000	E 20mm		7 Differential ABZ, 5-26VDC in, 5-26VDC out (7272)	E 3m (120") cable	
	0360 4096	F 7/8"	Not available when Code 6 is 0, 1, 5, 6, or H	8 Differential ABZ, 5-26VDC in, 5VDC out (4469)	F 0.3m (13") cable with 10 pin connector and mate	
	5000	G 24mm		9 Differential ABZ, 5-15VDC in, 5-15VDC out (4469)	G 0.3m (13") cable	
		H 1"	Not available when Code 6 is 0, 1, 5, 6, or H	D Dual isolated outputs, same as "6"	H 5 pin M12	
		J 1-1/8"		E Dual isolated outputs, same as "7"	J 8 pin M12	
		K 1-1/4"	Not available when Code 6 is 0, 1, 5, 6, or H	F Dual isolated outputs, same as "8"		
		M 14mm		G Dual isolated outputs, same as "9"		
		N 18mm	Not available when Code 6 is 0, 1, 5, 6, or H	N Same as "6" with Extended temp range		
		P 25mm		P Same as "7" with Extended temp range		
		R 28mm	Not available when Code 6 is 0, 1, 5, 6, or H	Q Same as "D" with Extended temp range		
				R Same as "E" with Extended temp range		

Headquarters: 1675 Delany Road • Gurnee, IL 60031-1282 • USA
 Phone: +1 847.662.2666 • Fax: +1 847.662.6633

Satellite Locations:

- North America: North Carolina, South Carolina, Connecticut, Massachusetts, New York, Canada, St. Kitts
- Europe: United Kingdom, Italy, France, Germany, Spain, Slovakia
- Latin America: Brazil • Asia: China, Japan, Korea, Singapore

Customer Service:

Tel.: +1.800.873.8731
 Fax: +1.847.662.4150
 custserv@dynapar.com

Technical Support

Tel.: +1.800.234.8731
 Fax: +1.847.782.5277
 dynapar.techsupport@dynapar.com

European Sales Representative

Hengstler GmbH
 Uhlandstrasse 49, 78554 Aldingen
 Germany
 www.hengstler.de



Factory Automation Worldwide Brands: NorthStar™ • Acuro™ • Dynapar™ • Hengstler™ • Harowe™

Application Assistance 1.800.234.8731 (847.662.6633)