

Pressure sensor SPAN

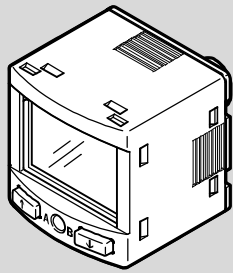

FESTO

Festo SE & Co. KG

Ruiter Straße 82
73734 Esslingen
Germany
+49 711 347-0
www.festo.com

Operating instructions

8035566
2017-11a
[8035568]

Translation of the original instructions



Pressure sensor SPAN English



For all available product documentation → www.festo.com/pk

1 Product description

The operating instructions describe the entire function range. The function range is limited, depending on the product variant.



Note

You can find detailed specifications for the product, the device description file (IODD) with a description of the IO-Link parameters and the declaration of conformity at: → www.festo.com/sp.

1.1 Overview

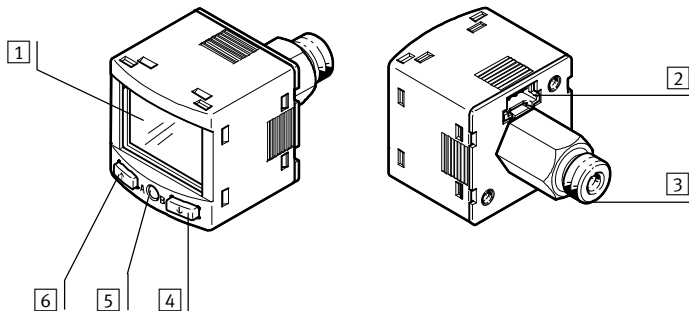

- 1 Display
- 2 Electrical connection
- 3 Pneumatic connection
- 4 B-key
- 5 Edit button
- 6 A-key

Fig. 1 Representation of other variants can deviate from this

1.2 Characteristics

Characteristic	Value	Description
Type	SPAN	Pressure sensor
Pressure measuring range	-B2, -B11, -P025, -P05, -P1, -P2, -P6, -P10, -P12, -P16, -V025, -V05, -V1	→ Technical data
Supply port	R	Relative pressure
Pneumatic port	-G18, -R18, N18, -M5, -Q4,	Thread G1/8, R1/8, NPT1/8, M5 Push-in connector 4 mm
Thread type	M F	None Male thread Female thread
Electrical output 1	-PNLK -PN	Switching output PNP / NPN / IO-Link PNP / NPN
Electrical output 2	-PNVBA -PN	PNP / NPN / 0...10 V / 1...5 V / 4...20 mA PNP / NPN
Electrical connection	-L1	Plug connector, design L1
Certificate	+T	Without With inspection report

Fig. 2

2 Safety

Intended use

The pressure sensor SPAN is intended for monitoring pressure of compressed air and inert gases in the piping.

General safety information

- Only use the product in its original status, without any unauthorised modifications.
- Only use the product if it is in an excellent technical status.
- The product is intended for use in industrial environments. Measures may need to be implemented in residential areas for radio interference suppression.
- Take into consideration the ambient conditions at the location of use.
- Operate the product only with compressed air of the specified air quality class (→ Technical data).
- Observe the specifications on the rating plate.
- Comply with all applicable national and international regulations.

Disposal

- Observe the local specifications for environmentally friendly disposal.

Range of applications and certifications

In connection with the UL marking on the product, the information of this section is also applicable for compliance with the certification conditions of Underwriters Laboratories Inc. (UL) for the U.S.A. and Canada.

UL approval information

Product category code	QUYX (USA) QUYX7 (Canada)
File number	E322346
Considered standards	UL 61010-1 C22.2 No. 61010-1
UL mark	US LISTED

Fig. 3

Unit shall be supplied by a power source which complies with the requirements of a limited-energy circuit in accordance with IEC/EN/UL/CSA 61010-1 or a Limited Power Source (LPS) in accordance with IEC/EN/UL/CSA 60950-1 or IEC/EN/UL/CSA 62368-1 or a Class 2 circuit in accordance with NEC or CEC.

3 Function and application

The sensor converts pneumatic pressure values (relative pressure) into electrical signals, which can be used for control or regulating functions. Measurements are carried out using a piezoresistive sensor element with a following electronic evaluation unit. Interfacing to the higher-level system is provided by 1 or 2 switching outputs, an optional analogue output and an optional IO-Link interface.

The switching outputs can be configured for monitoring of a threshold value, a pressure range or a differential pressure. The outputs can be set as PNP or NPN and normally open (NO) or normally closed (NC). Via the IO-Link interface, process values can be read out and parameters changed and transmitted to additional devices.

3.1 Operating statuses

Operating status	Function
RUN mode	- Basic status after the operating voltage is switched on - Display of the current measured value
SHOW mode	- Display of the current settings
EDIT mode	- Setting or modification of parameters
TEACH mode	- Acceptance of the current measured value to determine switching points

Fig. 4

3.2 Switching functions

Threshold value comparator for monitoring of a pressure threshold \lceil

Function	NO (normally open)	NC (normally closed)
Switching function: - 1 switching point (SP)		
TEACH mode: - 2 teach-in points (TP1, TP2) - SP = 1/2 (TP1+TP2)		

Fig. 5

Window comparator for monitoring of a pressure range []

Function	NO (normally open)	NC (normally closed)
Switching function: - 2 Switching points (SP.Lo, SP.Hi)		
TEACH mode ¹⁾ : - 2 teach-in points (TP1, TP2) - TP1 = SP.Lo, TP2 = SP.Hi		

1) SP.Lo = smaller pressure/vacuum value, SP.Hi = larger pressure/vacuum value, dependent on the Teach sequence

Fig. 6

Auto difference monitoring d []

This function permits monitoring of a pressure value for constancy. If the applied pressure is constant in the range between [SP.Lo] and [SP.Hi], the reference pressure P_{Ref} is automatically determined. The result is a switching operation at the output. The signal change signals the start of pressure monitoring. If the pressure remains in the monitoring range [d.SP] around P_{Ref}, the pressure is stable. When the monitoring range is left (e.g. caused by a leakage in the system), the output switches back.

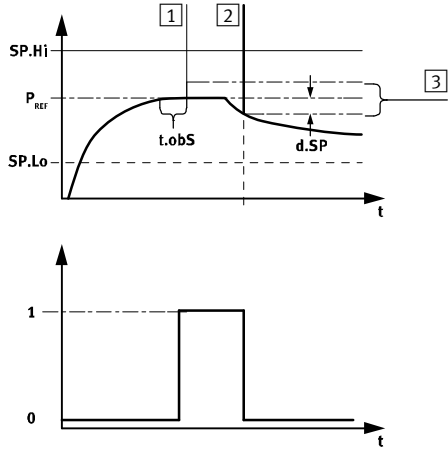

- 1 Reference value is determined
- 2 Measured value deviates by [d.SP] from the reference value
- 3 Monitoring area

Fig. 7

The parameters [SP.Lo], [SP.Hi], [t.obs] and [d.SP] can be configured by the user. The greater [t.obs] is set, the more constant the pressure signal must be to establish the reference value P_{Ref}.

Function	NO (normally open)	NC (normally closed)
Switching function: - 2 switching points (SP.Lo, SP.Hi) for setting the valid work range - 1 switching point (d.SP) for determination of the monitoring area		
TEACH mode ¹⁾ : - 2 teach-in points (TP1, TP2) - TP1 = SP.Lo, TP2 = SP.Hi		

1) SP.Lo = smaller pressure value, SP.Hi = larger pressure value, independent of the Teach sequence

Fig. 8

4 Installation

→ Note

Installation and commissioning are to be carried out only by qualified personnel in accordance with the operating instructions.

- Remove all transport packaging. The material used in the packaging has been specifically chosen for its recyclability.

4.1 Mechanical and pneumatic

→ Note

An unfavourable mounting position can impair the function of the product.

- Mount the sensor so that no condensate from the compressed air lines can gather in the device.
- Install the sensor so that it cannot be heated above the maximum permissible operating temperature (plan for convection possibilities).

SPAN-...-G18M/R18M/N18M

- Seal connecting thread.

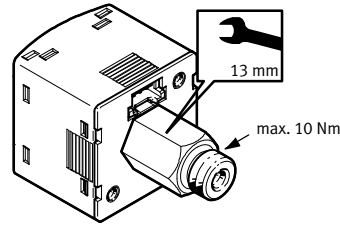

Fig. 9 Example with G18M

Mounting bracket

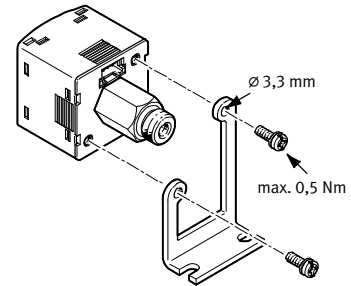
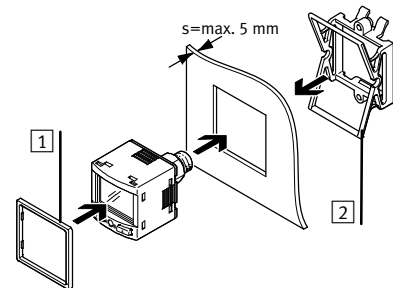
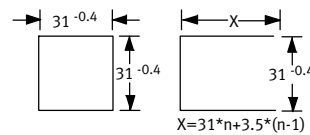

Fig. 10 Example with SAMH-PU-A-. Fastening SAMH-PN-W correspondingly

Front panel use SAMH-PN-F

- Size of the front panel cut-out in mm → Fig. 11.
- Fasten panel frame to the sensor.
- Guide sensor from the front into the cut-out on the front panel.
- Attach the clamping element and press until it catches.



- 1 Panel frame
- 2 Clamping element

Fig. 11

Fig. 12

4.2 Electrical



Warning

Use only power sources which guarantee reliable electrical isolation of the operating voltage in accordance with IEC/EN 60204-1. Consider also the general requirements for PELV circuits in accordance with IEC/EN 60204-1.

- Connect sensor.
- Consider the maximum permissible line length: 30 m (20 m for IO-Link).

Pin	Colour ¹⁾	Allocation	Plug L1
1	Brown (BN)	Operating voltage +24 V DC	
2	Black (BK)	Switching output OutA or IO-Link (C/Q line)	
3	White (WH)	Switching output OutB or analogue output (pressure signal InA)	
4	Blue (BU)	0 V	

1) Colours apply for connecting cables NEBS-L1... or electrical adapter SASC-P4... with NEBU-M8...

Fig. 13

Circuit diagrams

SPAN-...-PNLK-PNVBA	SPAN-...-PN-PN

Fig. 14

Fig. 15

5 Commissioning

5.1 LCD display

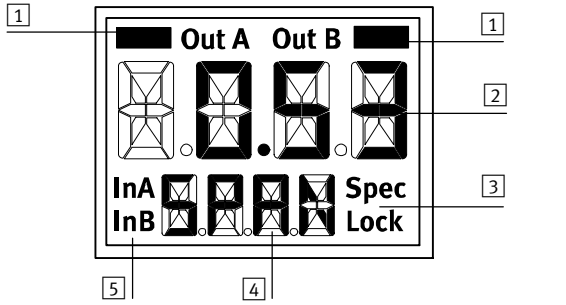

- 1 Output display
- 2 Main display (e.g. measured value)
- 3 Status information
- 4 Lower display (e.g. unit)
- 5 Signal indicator

Fig. 16

Example for LCD display	Meaning
Output display	
[OutA]	Switching output OutA selected (flashes with active IO-Link)
█ [OutA]	Switching output OutA set
[OutB]	Switching output OutB selected
[OutB] █	Switching output OutB set
Status information / signal indicator	
[Lock]	Security code activated (→ Chap. 5.4)
[Spec]	Special menu selected (→ Chap. 5.6)
[InA]	Pressure signal InA or analogue signal is selected
	Graphic bar graph in the lower display [Sub.d]

Fig. 17

Example for LCD display		Meaning
Main display	Lower display	
Measured value indicator and unit in the RUN mode		
[-0.53]	[bar]	Measured value indicator (here: negative value) and unit
Menu for the switching outputs (OutA and OutB)		
[Edit]	[bin]	Edit menu for the switching outputs (binary)
⌋	[Fctn]	Threshold value comparator
⌋⌋	[Fctn]	Window comparator
d⌋⌋	[Fctn]	Auto difference monitoring
[1.80]	[SP]	Value of switching point (only for threshold value comparator)
[2.45]	[SP.Lo]	Value of lower switching point
[6.45]	[SP.Hi]	Value of upper switching point
[0.50]	[HY]	Value of hysteresis
[18]	[t.obS] / [MSEC]	Time interval for determination of a mean value, which is used to determine the pressure change and establish the reference value.
[0.25]	[d.SP]	Threshold value of the differential pressure with auto difference monitoring
[NO]	[LOGC]	Switching characteristics: [NO] = normally open, [NC] = normally closed
[bLUE]	[COLR]	Display colour: [bLUE] = Blue, colour change function deactivated [R.ON] = Red, if switching output set [R.OFF] = Red, if switching output not set Note: Independent of the settings [COLR], the red colour change appears with some malfunctions.
Extreme values (only SHOW mode)		
[1.64]	[MIN]	Minimum measured pressure since switch-on or the last reset
[8.50]	[MAX]	Maximum measured pressure since switch-on or the last reset
Menu of the pressure signal (InA)		
[Edit]	[ANLG]	Edit menu for the analogue output
[1 _ 5]	[Out] / [V]	Output function of the analogue output
[93]	[In.Hi] / [%]	Scaling of the analogue output in percent of the final value of the pressure measuring range
[3]	[In.Lo] / [%]	Scaling of the analogue output in percent of the initial value of the pressure measuring range
Menu for device settings (Spec)		
[Edit]	[MENU]	Edit menu for additional settings
[16]	[Filt] / [MSEC]	Value of the filter time constant for the pressure measurement signal
[bar]	[Unit]	Unit for the pressure indicator

[OFF]	[Z.Adj]	[OFF] = zero point synchronisation (zero adjust) deactivated [ON] = offset correction for measured value indicator, switching points and analogue output possible
[Unit]	[Sub.d]	Settings of the lower display in RUN mode: selected unit or switching point of OutA or bar graph
[40]	[Eco] / [SEC]	Economy mode: period after which the display background lighting is switched off
[PNP]	[bin] / [Out]	Shift of the switching outputs (binary) between PNP and NPN
[bin]	[Pin3] / [Out]	Shift between switching output (binary) and analogue output (InA) at Pin3
[OFF]	[Code]	Activation and determination of the security code
[OFF]	[MASt]	Activation of the IO-Link master function for replication of parameters

Fig. 18

5.2 Switch on sensor (RUN mode)

- Switch on the operating voltage.
 - ➔ Current measured value is displayed. The sensor is in the basic status (RUN mode).

The basic status can be reached from other modes by:

- pressing edit button for 3 seconds
- expiration of a monitoring time (Timeout)

5.3 Displaying parameters (SHOW mode)

Requirement: The sensor is ready for operation (RUN mode).

Switching output OutA

- Press A-key.
 - ➔ The first parameter set is displayed. [Fctn] flashes.

The subsequent parameters can be displayed by repeatedly pressing the A key (➔ Fig. 19).

- ➔ At the end, the min. and max. values are displayed. This can be reset with the Edit key.

Switching output OutB or analogue output for pressure signal InA

- Press B-key.
 - ➔ The first parameter set is displayed. [Fctn] with OutB or [Out] with InA flashes.

The subsequent parameters can be displayed by repeatedly pressing the B-key (➔ Fig. 19).

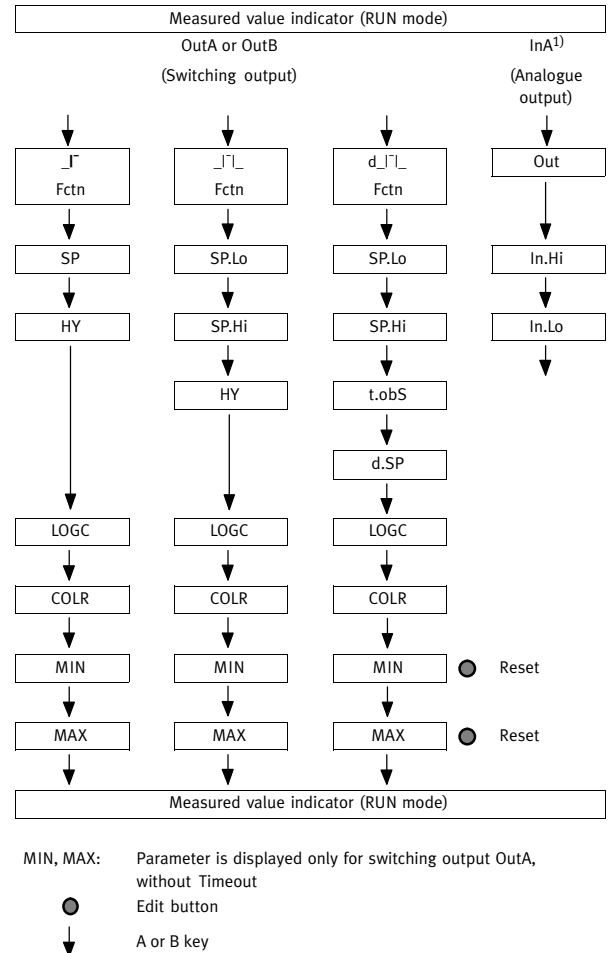

1) Only SPAN-...-PNLK-PNVBA; via B-key

Fig. 19

5.4 Enter the security code (EDIT mode)

Requirement: The sensor is ready for operation (RUN mode).

1. Press the Edit button.
 - The EDIT mode is active. If the security code is activated, the parameter entry option is blocked: [Lock] flashes.
2. Enter security code set with A or B key.
3. Press the Edit button briefly.
 - [OutA] flashes. The parameter entry option is unblocked.

5.5 Configuring switching output (EDIT mode)



Note

The process is the same for configuring the switching outputs for OutA and OutB. In the following, the process is described using the switching output OutA. Menu structure → Fig. 21.

Requirement: The sensor is ready for operation (RUN mode).

Set threshold value comparator $_I$, window comparator $_I$, auto difference monitoring d_I

1. Press the Edit button briefly.
 - [Edit] appears. [OutA] flashes.
 2. Press the Edit button briefly.
 - [Fctn] flashes.
 3. With A or B key, select $_I$ or $_I$ or d_I .
 4. Press the Edit button briefly.
 - The set value is saved.
 - The next adjustable parameter is shown.
 5. Set parameters with A- or B-key.
 6. Repeat points 4 and 5 until all parameters are set.
 7. Press the Edit button.
 - Switch to the RUN mode.
- Switching functions → Chapter 3.2

5.6 Change device settings (EDIT mode)

Requirement: The sensor is ready for operation (RUN mode).

1. Press the Edit button briefly.
 - [Edit] appears. [OutA] flashes.
2. With A or B key, select special menu [Spec].
 - [Spec] flashes.
3. Press the Edit button briefly.
 - [Filt] flashes.
4. Set parameters with A- or B-key.
5. Press the Edit button briefly.
 - The set value is saved
 - The next adjustable parameter is displayed.
6. Repeat points 4 and 5 until all parameters are set.

5.7 Set analogue output (EDIT mode)

Requirement: The sensor is ready for operation (RUN mode).

1. Press the Edit button briefly.
 - [Edit] appears. [OutA] flashes.
2. Select [InA] with the A-key or B-key.
 - [Edit] appears. [InA] flashes.
3. Press the Edit button briefly.
 - [Out] flashes.
4. Set parameters with A- or B-key.
5. Press the Edit button briefly.
 - The set value is saved.
 - The next adjustable parameter is shown.
6. Repeat points 4 and 5 until all parameters are set.
7. Press the Edit button.
 - Switch to the RUN mode.

5.8 Replicating parameters (EDIT mode)

Requirement:

- The pre-configured sensor (master sensor) is ready for operation (RUN mode).
- Master sensor and device sensor have the same design regarding the parameters (same device ID).
- The master sensor is connected with the device sensor (→ Fig. 20).
- Parameterisation of the device sensor must not be blocked via IO-Link®.
- The device sensor is in an unswitched status (switching output PNP, display OutA off).

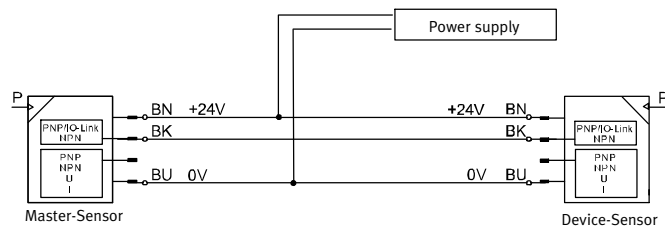

Fig. 20

1. Select special menu [Spec] at the master sensor via device settings.
2. Press the Edit button briefly until [MASt] appears.
3. With A or B key, select [ON].
4. Press the Edit button
 - [REPL] / [RedY] appears.
5. Press A- or B-key.
 - [REPL] / [RUN] appears briefly.
 - The parameters are transmitted to the device sensor.
 - [REPL] / [RedY] appears.

If an error occurs, an error message appears (→ Fig. 22).
6. Repeat point 5 if an additional sensor should be parameterised.
7. Press the Edit button briefly.
 - Switch to the RUN mode.

5.9 Menu structure

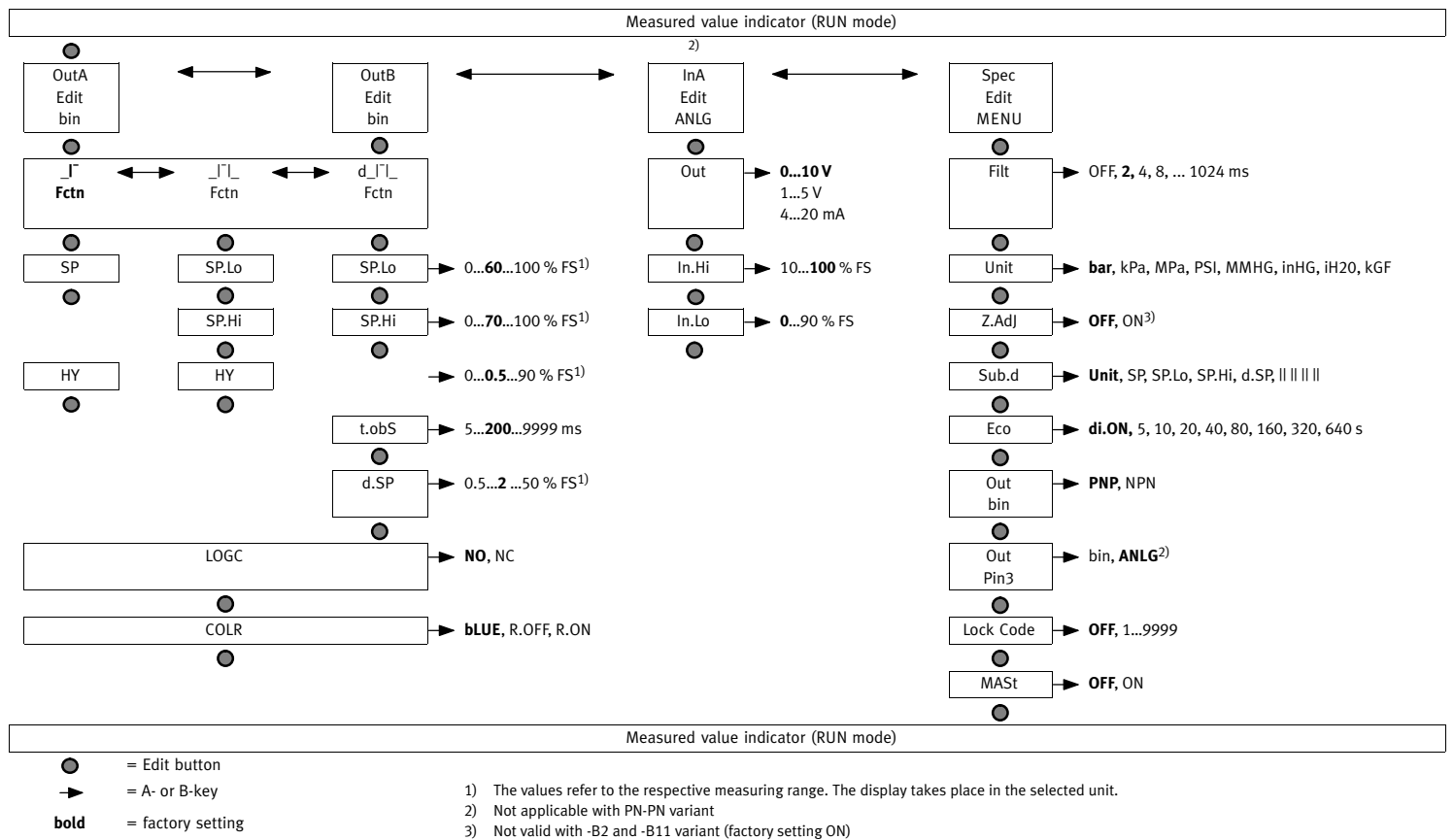

Fig. 21

5.10 Zero point synchronisation (zero adjust)

Requirement:

- The sensor is ready for operation (RUN mode).
- [Z.Adj][ON] is set (→ Chap. 5.6).
- The measured value lies in the range $0 \text{ bar} \pm 3 \% \text{ FS}$.

- Press the A- and B-key and Edit button simultaneously.
 - [OK] appears. The zero point synchronisation was successful.
 - [FAIL] appears. The zero point synchronisation was not successful. Check requirements.



Note

If [Z.Adj][OFF] is set for a later time, the device takes over the factory setting calibration values.

5.11 Teach switching points (TEACH mode)



Note

The process for teaching the switching outputs for OutA (A-key) and OutB (B-key) is the same. In the following, the process is described using the switching output OutA.



Note

There is no Timeout in the TEACH mode. The sensor changes to the RUN mode only after the entire teach process is ended.

Requirement: The sensor is ready for operation (RUN mode).

If the security code is activated, the parameter entry option is blocked: [Lock] flashes.

- Enter the security code (→ Chap. 5.4).

1. Establish switching function in the EDIT mode (→ Chap. 5.5).
2. Create pressure value 1.
3. Press the A-key and Edit button.
 - The current pressure value will then be adopted as the first teach point (TP1).
 - [t-IN] flashes.
4. Create pressure value 2.
5. Press the A-key and Edit button.
 - The current pressure value is adopted as the second teach point (TP2).
 - Switch to the RUN mode.

6 Operation



Caution

Property damage due to high temperatures.

Extreme pneumatic conditions (high cycle rate with large pressure amplitude) can heat the product above 80° C.

- Select the operating conditions (in particular the ambient temperature, pressure amplitude, cycle rate, current consumption) such that the product does not heat up above the maximum permitted operating temperature.

Restoring factory settings (restore)



Note

By resetting to factory settings, the current settings are lost.

1. Switch off the operating voltage.
2. Keep the A- and B-keys pressed down simultaneously.
3. Switch on the operating voltage.
4. Additionally press the Edit button.
 - [Rsto][PARM] appears. All parameters are reset to the factory settings (→ Fig. 21).

7 Maintenance and care

1. Switch off the energy sources (operating voltage, compressed air).
2. Clean sensor with non-abrasive cleaning agents.

8 Disassembly

1. Switch off the energy sources (operating voltage, compressed air).
2. Separate connections from the sensor.
3. Loosen the mountings.

9 Fault clearance

Malfunction	Possible cause	Remedy
No display	No operating voltage or impermissible operating voltage	• Apply permissible operating voltage
	Electrical connections swapped	• Connect the device in accordance with the circuit diagram
	Device defective	• Replace device
Display or switching output does not react in accordance with the settings	Short circuit or overload at the output	• Eliminate short circuit or overload
	Incorrect switching point taught (e.g. at 0 bar)	• Repeat teaching procedure
	Device defective	• Replace device
	Parameter incorrect	• Reset to factory settings
[Er01] / [FAIL] ¹⁾	Device defective	• Replace device
[Er02] / [ASIC] ¹⁾	Device defective	• Replace device
[Er10] / [OVER]	Measuring range exceeded	• Comply with the measuring range
[Er20] / [tEMP] ²⁾	Temperature error	• Check operating conditions • Replace device
[Er21] / [SHRT] ²⁾	Short circuit at OutA	• Eliminate short circuit
[Er22] / [SHRT] ²⁾	Short circuit at OutB	• Eliminate short circuit
[Err] / [BUSY]	OutA is switched active	• Check device settings
[Err] / [ID]	Device ID error, replication function failed	• When replicating, use sensors with the same type (same device ID)
[Err] / [COMM]	IO-Link communication error	• Check line OutA • Check settings of the device sensor

- 1) Display flashes red
2) Display illuminated red

Fig. 22

10 Accessories

Accessories: → www.festo.com/catalogue

11 Technical data

SPAN-		
General		
Approval certificate	c UL us – Listed (OL)	
	RCM	
CE marking (→ declaration of conformity)	In accordance with EU EMC directive	
Note on materials	RoHS compliant	
Input signal / measuring element		
Operating medium	Compressed air in accordance with ISO 8573-1:2010 [7:4:4]; inert gases, operation with lubricated medium possible	
Temperature of medium [°C]	0 ... +50	
Ambient temperature [°C]	0 ... +50	
Output, general		
Accuracy		
– P16 [% FS]	±2 at room temperature	
– B2, B11, V1, P1, P2, P6, P10, P025, P05, V025, V05, P12 [% FS]	±1.5 at room temperature	
– B2, B11, V1, P1, P2, P6, P10 [% FS]	±3 in the entire temperature range	
– P025, P05, V025, V05, P12, P16 [% FS]	±4 in the entire temperature range	
Repeat accuracy [% FS]	±0.3 with Filt = OFF	
Temperature coefficient [% FS/K]	Typically 0.05	
Switching output		
Switching output	2x PNP or 2x NPN switchable	
Switching function	Threshold value comparator Window comparator Auto difference monitoring	
Switch-on/switch-off time [ms]	typ.: 2, max.: 4 with Filt = OFF	
Max. output current [mA]	100	
Capacitive load maximum DC [nF]	100	
Voltage drop [V]	Max. 2	
Pull-down resistor	integrated (PNP)	
Pull-up resistor	not integrated (NPN)	
Inductive protective circuit	Present	
Analogue output		
Output characteristic curve [V]	0 ... 10	
initial value ... end value [V]	1 ... 5	
[mA]	4 ... 20	
Max. load resistance of current output [Ω]	500	
Min. load resistance of voltage output [kΩ]	20	
Output, additional data		
Short circuit protection	Yes	
Overload protection	Present	
Electronics		
Max. current consumption [mA]	230	
Nominal operating voltage DC [V]	24	
Operating voltage range DC [V]	15 ... 30	

No-load supply current [mA]	Max. 30
Ready-state delay [ms]	typ. 80 ¹⁾
Protection against polarity reversal	All connections against each other
Mechanical system	
Mounting position	Any, avoid condensation gathering in the sensor
Housing material	PA reinforced
Keyboard material	TPE-O
Threaded connections material	Brass (nickel-plated)
Display	
Displayable units	bar, kPa, MPa, psi, mmHg, inchHg, inchH ₂ O, kgf/cm ²
Immissions / emissions	
Storage temperature [°C]	–20 ... +80
Max. permissible relative air humidity [%RH]	85
Degree of protection (in accordance with EN 60529)	IP40
Protection class (in accordance with DIN VDE 0106-1)	III
Resistance to shocks (in accordance with EN 60068-2)	30 g acceleration with 11 ms duration (half-sine)
Vibration resistance (in accordance with EN 60068-2)	10 ... 60 Hz: 0.35 mm / 60 ... 150 Hz: 5 g

1) After this time, the electrical outputs take a defined, stable condition

Fig. 23

SPAN-	-B2	-B11	-V025	-V05	-V1	-P025	-P05
Pressure measuring range [bar]	-1		0				
[MPa]	-0.1		0				
Start value							
Pressure measuring range [bar]	1	10	-0.25	-0.5	-1	0.25	0.5
[MPa]	0.1	1	-0.025	-0.05	-0.1	0.025	0.05
End value							
Overload range [bar]	-1						
[MPa]	-0.1						
Overload range [bar]	5	15	1	2	5	1	2
[MPa]	0.5	1.5	0.1	0.2	0.5	0.1	0.2

Fig. 24

SPAN-	-P1	-P2	-P6	-P10	-P12	-P16
Pressure measuring range [bar]	0					
[MPa]	0					
Start value						
Pressure measuring range [bar]	1	2	6	10	12	16
[MPa]	0.1	0.2	0.6	1	1.2	1.6
End value						
Overload range [bar]	-1					
[MPa]	-0.1					
Overload range [bar]	5	6	15		20	
[MPa]	0.5	0.6	1.5		2.0	

Fig. 25

UL - Electrical and environmental ratings

Input voltage	max. 30 V DC, Class 2
Input current	max. 0.23 A
Power	max. 6.9 W
Pressure differential	max. 1.6 MPa
Ambient temperature	max. 50 °C / 122 °F
Pollution degree	3
Max. permissible relative humidity	85 %
Only for indoor use.	
Altitude up to 2000 m. Altitude up to 2000 m or above 2000 m if specified by the manufacturer.	

Fig. 26

IO-Link¹⁾

Protocol version	Device V1.1
Profiles	Smart sensor profile
Function classes	Binary data channel (BDC) Process data variable (PDV) Identification Diagnostics Teach channel
Communication mode	COM2 (38.4 kBaud)
Port class	A
Process data width IN	2 byte
Process data content IN	2 bit BDC (pressure monitoring) 14 bit PDV (pressure reading)
IODD, IO-Link device description	→ www.festo.com/sp

1) Only SPAN-...-PNLK-PNVBA

Fig. 27