

# Position Encoding System WCS\* Read Head

## Electrical Data

Manual

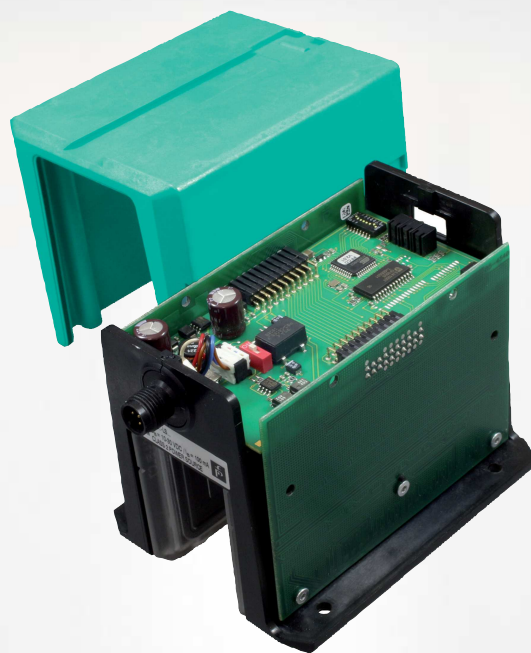

**SSI** CANopen<sup>®</sup> EtherNet/IP<sup>™</sup> **PROFI**<sup>®</sup>  
**NET** EtherCAT<sup>®</sup>

Your automation, our passion.

**PF** PEPPERL+FUCHS

---

With regard to the supply of products, the current issue of the following document is applicable:  
The General Terms of Delivery for Products and Services of the Electrical Industry, published  
by the Central Association of the Electrical Industry (Zentralverband Elektrotechnik und Elek-  
troindustrie (ZVEI) e.V.) in its most recent version as well as the supplementary clause:  
"Expanded reservation of proprietorship"

**Worldwide**

Pepperl+Fuchs Group  
Lilienthalstr. 200  
68307 Mannheim  
Germany  
Phone: +49 621 776 - 0  
E-mail: [info@de.pepperl-fuchs.com](mailto:info@de.pepperl-fuchs.com)

**North American Headquarters**

Pepperl+Fuchs Inc.  
1600 Enterprise Parkway  
Twinsburg, Ohio 44087  
USA  
Phone: +1 330 425-3555  
E-mail: [sales@us.pepperl-fuchs.com](mailto:sales@us.pepperl-fuchs.com)

**Asia Headquarters**

Pepperl+Fuchs Pte. Ltd.  
P+F Building  
18 Ayer Rajah Crescent  
Singapore 139942  
Phone: +65 6779-9091  
E-mail: [sales@sg.pepperl-fuchs.com](mailto:sales@sg.pepperl-fuchs.com)  
<https://www.pepperl-fuchs.com>

<b>1</b>	<b>Introduction.....</b>	<b>5</b>
1.1	Content of this Document.....	5
1.2	Target Group, Personnel .....	5
1.3	Symbols Used .....	6
<b>2</b>	<b>Product Description .....</b>	<b>7</b>
2.1	Functional Description .....	7
2.2	Areas of Use .....	10
<b>3</b>	<b>Data Cables and Mounting/Dismounting the Read Head .....</b>	<b>13</b>
3.1	Data cable.....	13
3.2	Mounting/Dismounting the Read Head Enclosure.....	14
<b>4</b>	<b>RS-485 Interface (LS1xx*, LS2xx*).....</b>	<b>16</b>
4.1	Electrical Connection and Data Cables.....	16
4.2	Hardware Configuration.....	19
4.3	Data Protocols .....	22
4.4	Status and Error Messages .....	28
4.5	LED Status Indication.....	29
<b>5</b>	<b>SSI Interface (LS3xx*) .....</b>	<b>31</b>
5.1	Electrical Connection and Data Cables.....	31
5.2	Hardware Configuration.....	33
5.3	Data Protocols .....	35
5.4	Status and Error Messages .....	37
5.5	LED Status Indication.....	38
<b>6</b>	<b>CANopen Interface (LS4xx*).....</b>	<b>39</b>
6.1	Electrical Connection .....	39
6.2	Hardware Configuration.....	41
6.3	Software Configuration .....	43
6.4	Data Protocols .....	43
6.5	LED Status Indication.....	44
<b>7</b>	<b>EtherNet/IP Interface (LS5xx*) .....</b>	<b>45</b>
7.1	Electrical Connection .....	46
7.2	Hardware Configuration.....	48

7.3	Software Configuration .....	49
7.4	Data Protocols.....	52
7.5	LED Status Indication .....	56
<b>8</b>	<b>PROFINET Interface (LS6xx*) .....</b>	<b>57</b>
8.1	Electrical Connection .....	58
8.2	Hardware Configuration .....	48
8.3	Software Configuration .....	61
8.4	Data Protocols.....	63
8.5	LED Status Indication .....	66
<b>9</b>	<b>EtherCAT® Interface (LS7xx*) .....</b>	<b>67</b>
9.1	Power Source .....	68
9.2	Hardware Configuration .....	70
9.3	EtherCAT® Communication Methods .....	72
9.4	Software Configuration .....	73
9.5	Data Protocols.....	83
9.6	Process Data Objects (PDOs).....	87
9.7	Firmware Update via the "File access over EtherCAT®" (FoE) protocol	92
9.8	LED Status Indication.....	94
9.9	Trademarks .....	95
<b>10</b>	<b>Options and Special Functions .....</b>	<b>96</b>
10.1	Option D—Integrated Display in the Read Head, Type LS...D.....	96
10.2	Option-E—Extended, Type WCS3B-LS*E*, RS-485 .....	98
10.3	Option-H—Heating in Read Head, Type LS...H .....	101
10.4	Option-S—Velocity Output, Type LS...S .....	101
<b>11</b>	<b>Model Overview for WCS Read Heads .....</b>	<b>102</b>
<b>12</b>	<b>Disposal .....</b>	<b>104</b>
<b>13</b>	<b>Appendix.....</b>	<b>105</b>
13.1	Cable Overview .....	105

# 1 Introduction

## 1.1 Content of this Document

This document contains information required to use the product in the relevant phases of the product life cycle. This may include information on the following:

- Product identification
- Delivery, transport, and storage
- Mounting and installation
- Commissioning and operation
- Maintenance and repair
- Troubleshooting
- Dismounting
- Disposal



---

### Note

For full information on the product, refer to the further documentation on the Internet at [www.pepperl-fuchs.com](http://www.pepperl-fuchs.com).

---

The documentation comprises the following parts:

- This document
- Datasheet

In addition, the documentation may comprise the following parts, if applicable:

- EU-type examination certificate
- EU declaration of conformity
- Attestation of conformity
- Certificates
- Control drawings
- Instruction manual
- Other documents

## 1.2 Target Group, Personnel

Responsibility for planning, assembly, commissioning, operation, maintenance, and dismantling lies with the plant operator.

Only appropriately trained and qualified personnel may carry out mounting, installation, commissioning, operation, maintenance, and dismantling of the product. The personnel must have read and understood the instruction manual and the further documentation.

Prior to using the product make yourself familiar with it. Read the document carefully.

### 1.3 Symbols Used

This document contains symbols for the identification of warning messages and of informative messages.

#### Warning Messages

You will find warning messages, whenever dangers may arise from your actions. It is mandatory that you observe these warning messages for your personal safety and in order to avoid property damage.

Depending on the risk level, the warning messages are displayed in descending order as follows:



---

#### **Danger!**

This symbol indicates an imminent danger.

Non-observance will result in personal injury or death.

---



---

#### **Warning!**

This symbol indicates a possible fault or danger.

Non-observance may cause personal injury or serious property damage.

---



---

#### **Caution!**

This symbol indicates a possible fault.

Non-observance could interrupt the device and any connected systems and plants, or result in their complete failure.

---

#### Informative Symbols



---

#### **Note**

This symbol brings important information to your attention.

---



---

#### **Action**

1. This symbol indicates a paragraph with instructions. You are prompted to perform an action or a sequence of actions.

## 2 Product Description

### 2.1 Functional Description

The WCS position encoding system consists of two main components:

#### Code Rail

The code rail carries information for the absolute code. The code rail is routed parallel to the track for the material handling equipment and thus assigns a unique position to every point on the track. It is possible to route the code rail at points only where positioning is required. The system allows the code rail to be routed along curves and allows branches to be created. The code rail is built to order and delivered in a bundle. Unless otherwise ordered, the code rail always starts with position value 0 and ends with a maximum position according to the ordered length in meters. The length of a code rail segment ranges from 0 to a maximum total length of 314.573 m (WCS3) or from 0 to a maximum total length of 327 m (WCS2).

Spacers can also be ordered for repair purposes or specific applications, stating the start or end position of the desired section and the desired length in meters.

For identification applications ID-pads are available as short code rail sections, with a length of between 250 mm and 264 mm and a unique identification number.

#### Read Head

The U-shaped read head scans the code rail photoelectronically without touching it. The read head detects a new position value every 0.8 mm (WCS3) or 0.833 mm (WCS2).

This results in the following data:

	WCS2B	WCS3B
Resolution	± 0.42 mm 1200 pos./m	± 0.40 mm 1250 pos./m
Movement speed [ $v_{max}$ ]	12.5 m/s	12.5 m/s
Y axis (tolerance)	± 5 mm	± 15.5 mm
X axis (tolerance)	± 5 mm	± 14 mm

After insertion into the code rail, the read head determines a highly accurate position value without reference or delay. The code rail can be scanned at very high speeds. The scanning can be reproduced, is reliable, and is independent of temperature fluctuations.

The position value, movement speed, and error codes such as the contamination detection or the "OUT" message can be transmitted directly from the read head to the control panel via a communication interface. There are a number of types of interfaces available in the WCS3 read head to achieve this, such as RS-485, SSI, CANopen, PROFINET, and EtherNet/IP.

There is a wide range of interface modules available for connecting to other interfaces:

- PROFINET
- PROFIBUS DP
- EtherNet/IP
- EtherCAT
- DeviceNet
- CANopen

Each interface module can simultaneously accommodate up to four read heads with an RS-485 interface and address each separately. This makes it easy to extend your plant at a later stage.

In addition to automatic contamination detection, there are other optional extensions for the WCS read head. The options are indicated in the type code with the corresponding letter:

WCS2B and WCS3B	
<b>H</b>	Integrated heating element for an extended outside temperature range as low as - 40 °C.

WCS3B	
<b>D</b>	Integrated display with a seven-segment display for position and diagnostic information.
<b>E</b>	Read head with Extended option for long distances of up to 629.146 meters.
<b>O</b>	Outdoor protective enclosure with degree of protection IP69 for outdoor use.
<b>S</b>	Switching output for signaling when a limit speed is exceeded

The variants available can be found in the product selector at <https://www.pepperl-fuchs.com>, as well as in the model overview for read heads, see chapter 11.

## Mounting System

There are three different mounting systems available for mounting the code rail. The bracket system, the WCS3 aluminum profile system, and the WCS2 aluminum profile system with fixture for a guide trolley. The three mounting systems can be screwed directly to the surface or mounted on standard C profiles.

The bracket system is the easiest to mount as it features mounting brackets for straight section elements and curved sections (vertical, horizontal). The brackets are screwed directly to the code rail and to the surface and C profile.

As an alternative to the mounting brackets, the WCS3 aluminum profile system provides better stabilization of the code rail and simplified mounting for long, straight sections. In this case, the code rail is inserted into an extruded aluminum profile developed for the WCS and fixed in place with a fixing cord. The aluminum profile rail is clipped to plastic brackets and attached to the surface with a C profile.

The WCS2 aluminum profile rail system with guide trolley is intended for applications with high running tolerances. The aluminum profile accommodates the code rail and the guide trolley. The guide trolley is connected to the vehicle via a free-running tappet and guarantees that the read head is always in the optimal position in relation to the code rail. At the same time, the read head is decoupled from vehicle vibrations. Use of the guide trolley is generally recommended with the WCS2 read head due to the low read head gap. For the WCS3 read head with outdoor protective enclosure, an optional guide trolley can be used in combination with the WCS2 profile rail.



### Properties of the WCS

- Absolute position encoding system
- Photoelectric principle (infrared range)
- Proven and robust
- Easy to maintain
- No reference points required
- No calibration and adjustment work necessary
- Resistant to power failure
- Millimeter-precise positioning with absolute repeat accuracy
- Determination of position value in real time and regardless of temperature fluctuations
- Guaranteed reading up to a speed of 12.5 m/s
- High resolution =  $\pm 0.4$  mm
- Variable route length:
  - Up to 327 m (WCS2)
  - Up to 314.573 m (WCS3)
  - Up to 629.146 m (WCS Extended)
- The coding system is also suitable for curves with a radius of up to 0.5 m (does not apply to systems with guide trolleys)
- A wide range of areas of application, e.g., automated storage and retrieval systems, moving carriages, monorail conveyors, galvanic plants, automatic and slewing cranes, elevators, as well as outdoors such as in harbors, offshore installations, and ships
- Various mounting systems available for installing the code rail
- Connection to any control panel possible, either directly or via interface module
- Connectivity to many fieldbus systems available
- Support during commissioning and maintenance due to extensive system diagnostics options
- High functional reliability as a result of permanent self-diagnostics
- Contamination warning
- Optional heating for ambient temperatures down to  $-40$  °C
- Digital output of an adjustable limit speed (optional)
- The WCS3-Outdoor has an IP69-compliant protective enclosure

## 2.2 Areas of Use

The WCS can be used anywhere where material handling equipment has to be positioned precisely. The operating principle of the WCS enables it to be used in a diverse range of applications, including:

- Interruptions in the code rail
- Applications with curves and circular paths
- Use of multiple vehicles in a row

Due to the large tolerance between the read head and code rail, the WCS can be used for most applications. In some cases, however, it is advantageous to use the WCS with a special protective enclosure or a guide trolley in conjunction with the aluminum profile system. Here are some examples from the variety of application options:

### Automated Storage and Retrieval Systems (High-Bay Warehouses)

Moving carriages, lifting gear, and transversing carriages are each positioned with one read head. The positioning is independent of the length of the code rail and always absolutely reproducible. For new high-bay warehouses we recommend the WCS3 system. For retrofits in older warehouses, it may be beneficial to use the WCS2 in conjunction with the aluminum profile system:

- Easy to retrofit
- High mechanical tolerances between the measuring system and moving carriages possible
- Decoupling of vehicle vibrations

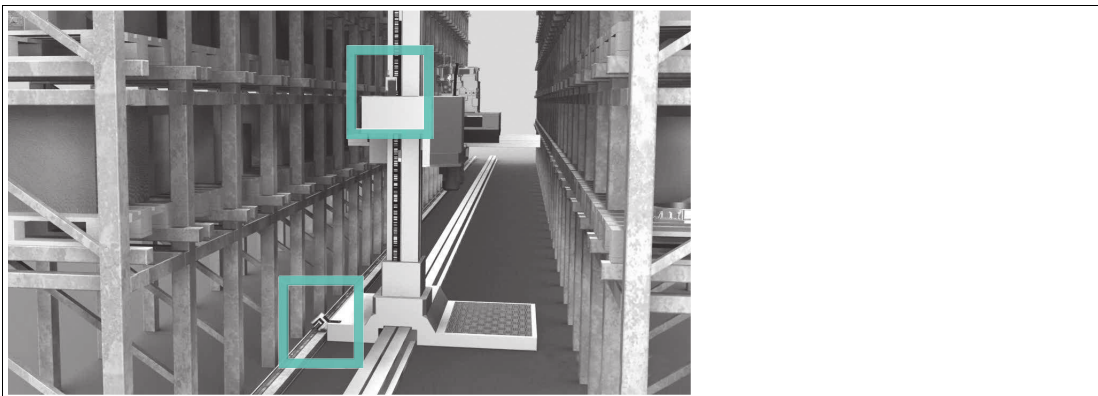

Figure 2.1 Automated storage and retrieval system (high-bay warehouse)

### Automatic Cranes

Automatic cranes are a typical application for the WCS2 in conjunction with the aluminum profile system. The crane is positioned using one read head each for the crane and the trolley movement. At each point, the guide trolley ensures the optimal position of the read head in relation to the code rail and decouples any vibrations from the crane track. Optional cleaning brushes for the code rail can be attached to the guide trolley. This means that the WCS can be used in a very dusty environment, such as in cement works or foundries. If the cranes are used outdoors, the WCS3 is used with a special protective enclosure.



Figure 2.2 Automatic crane

### Galvanic Plants

One or more vehicles in succession moving along a straight route. The vehicles automatically bring the material to be galvanized into the corresponding bath. The high and adaptable light output of the read heads has enabled the WCS position encoding system to perform extremely well even under these difficult conditions. The WCS3 with protective enclosure is ideal for galvanic plants. In addition to degree of protection IP69, the enclosure is resistant to acids and alkalis.

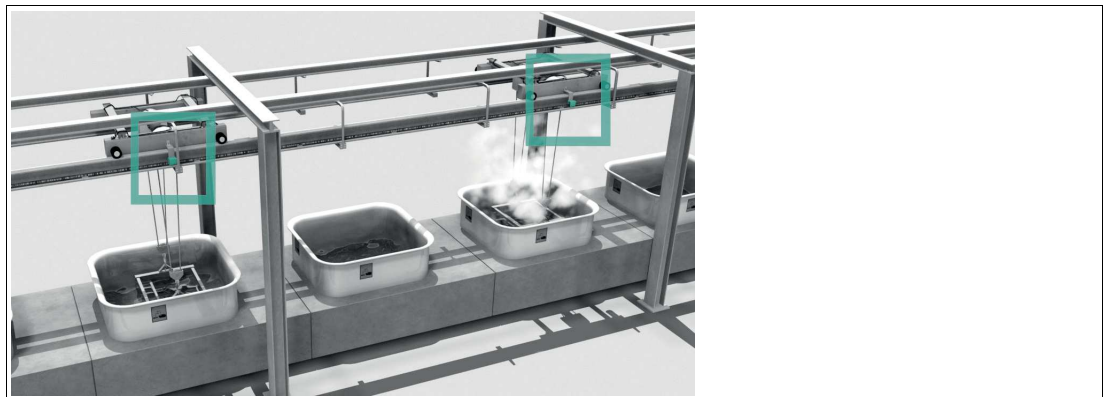

Figure 2.3 Galvanic plant

## Overhead Conveyors

Many vehicles have to be positioned on a circular track—the WCS offers the optimal solution for this. Branches (track switches) and curves can be created. The WCS3 is particularly well-suited for this task. After a power failure, the current position of the vehicle is transferred to the control panel immediately; the vehicle does not have to be moved. The WCS can also be used for distances longer than 314.573 m.

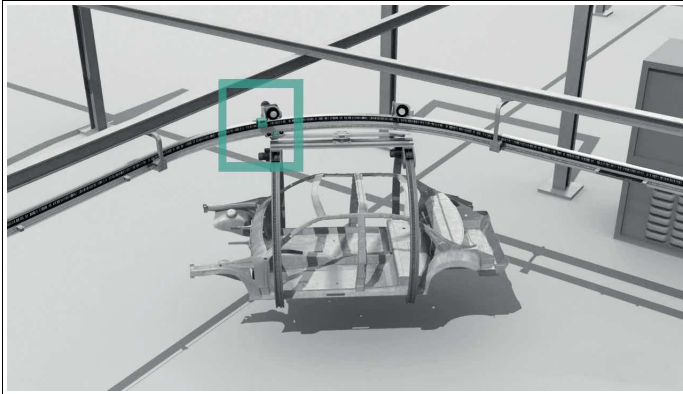

Figure 2.4 Overhead conveyor

## Harbor Applications

The WCS with protective enclosure is used for material handling plants in particularly demanding areas such as harbors, offshore installations, and ships. To meet the requirements of these areas, the WCS includes an IP69-compliant protective enclosure that, in addition to protecting against dust and humidity, has been specifically designed for resistance to aggressive substances such as salt water, salty air, acids, and alkalis. It offers increased impact resistance compared to typical outdoor sources of interference such as falling branches and hailstorms. In combination with built-in heating, the WCS can even be used in snow and temperatures as low as  $-40\text{ }^{\circ}\text{C}$ . The indicator LEDs and the display are always visible through the translucent enclosure material.

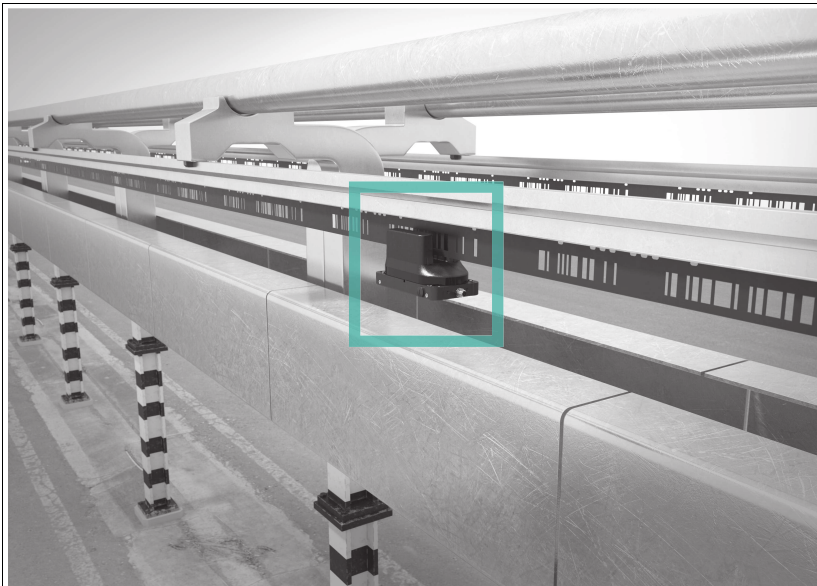

Figure 2.5 Power rail of a gantry crane

## 3 Data Cables and Mounting/Dismounting the Read Head

### 3.1 Data cable

A shielded data cable with twisted-pair wires is used for the electrical connection. Pepperl and Fuchs can supply suitable preassembled M12 single-ended female cordsets (see chapter 13.1) or field-attachable M12 single-ended female cordsets and data cables.

#### Data cable WCS-DC\*

There are 2 types of data cable available:

- **WCS-DCS** for stationary cable routing
- **WCS-DCF** for trailing cable and drag chain installations.

The data cables are twisted pairs and have a tinned copper braided shield. The braided shield surrounds all wire pairs. The parameters of the data cables that are suitable for RS-485, SSI, and CANopen data transfer are listed in the table below.

	WCS-DCS	WCS-DCF
Capacitance (core-core)	120 pF/m	60 pF/m
Cross section	0.14 mm <sup>2</sup>	0.25 mm <sup>2</sup>
Number of wires	6 (3 x 2)	6 (3 x 2)
External diameter	5.8 mm	7.5 mm
Temperature range	-40 ... 80 °C	-40 ... 70 °C

#### Cable routing

The basic prerequisite for uninterrupted data transfer is that the data cables are routed in such a way that any coupling of electromagnetic fields and interference is excluded. For EMC-compliant cable routing, it is necessary to divide the cables into cable groups and route these groups separately.

##### Group A

- Shielded data cable (including analog)
- Unshielded cable for DC and AC voltages 0 ... 60 V
- Shielded cable for DC and AC voltages 0 ... 230 V
- Coaxial cables for monitors

##### Group B

- Unshielded cable for DC and AC voltages 60 ... 400 V

##### Group C

- Unshielded cable for DC and AC voltages greater than 400 V

#### Shielding cables

The shielding of cables is required to suppress electromagnetic interference. Establishing a low resistance or low impedance connection with the protective conductor is a particularly important factor in ensuring that these interference currents do not become a source of interference themselves.

The WCSB2B and WCS3B read heads have no connection option for the cable shield. The cable shield is connected to the plant potential in the switch cabinet with low resistance (large area). In the case of high electromagnetic interference, it is advisable to connect the shield of the data cable to the plant potential in the immediate vicinity of the read head with low resistance using a grounding clip.

## 3.2 Mounting/Dismounting the Read Head Enclosure

If required, the factory default setting of the read head can be changed using the respective DIP switches. The DIP switches are located inside the housing on the PCB of the read head. To access the DIP switches, open the enclosure cover of the read head. Proceed as follows:



### Mounting/Dismounting

1. Disconnect the device from the power supply.

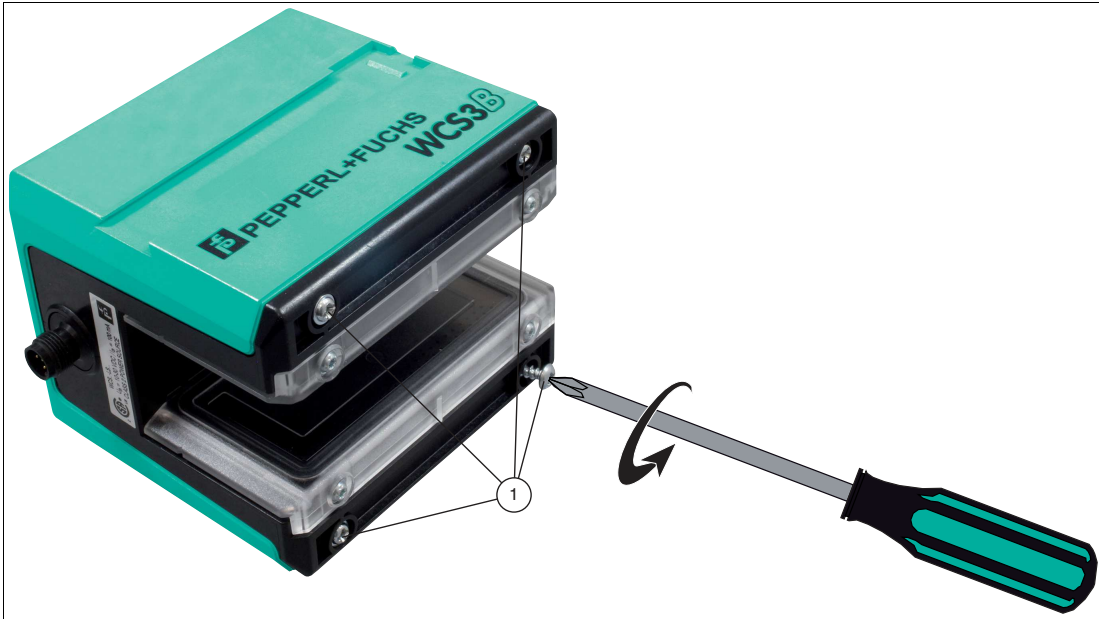

Figure 3.1 Opening the read head

2. Open the read head by removing the four screws (4) on the bottom of the read head.



#### Warning!

Property damage caused by electrostatic discharge (ESD)

If the housing is opened, the electronics may be damaged by electrostatic discharges.

- Use a wrist grounding strap or other ESD protective measures.



Figure 3.2 Removing the enclosure cover

3. Remove the enclosure cover (1) from the read head. To do this, carefully pull the enclosure cover upward.

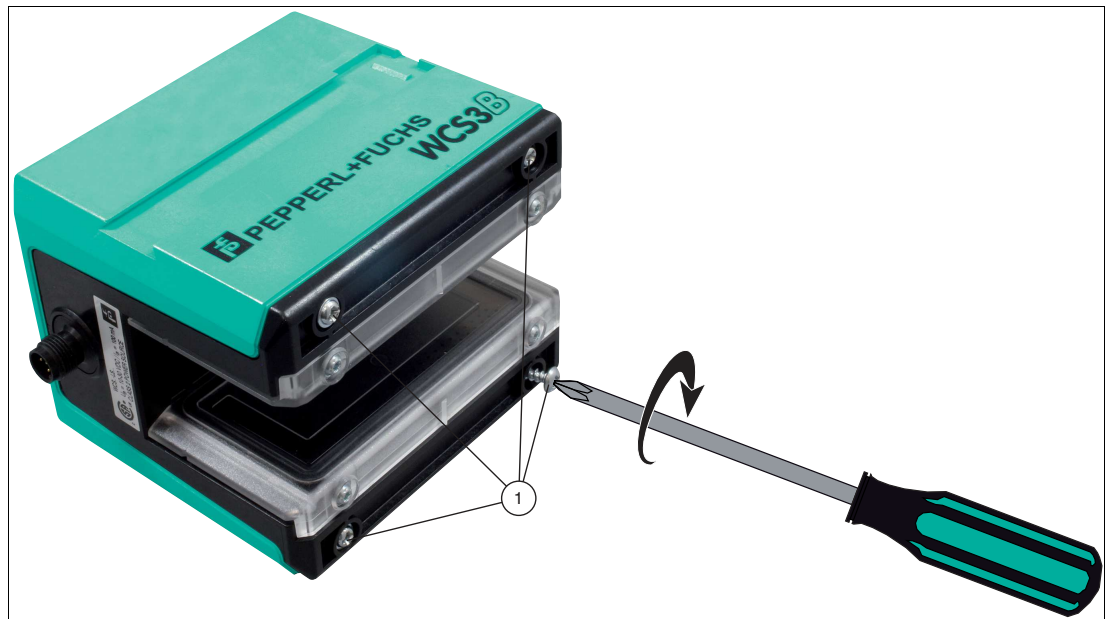

Figure 3.3 Mounting the enclosure cover

4. After making all adjustments, carefully slide the enclosure cover onto the read head and screw it into place with the four screws.



**Note**

The settings of the DIP switches for the respective interfaces can be found in the following chapters, under the menu item Hardware Configuration.

## 4 RS-485 Interface (LS1xx\*, LS2xx\*)

The serial interface of the read head allows the position values and other defined operating data to be read out.

Up to four WCS2B and/or WCS3B read heads can be interconnected in one RS-485 bus line. In this case, the read heads must have different addresses. The read head address must be configured in the read head if it has not already been set. If the read head address is already preset, this is indicated by the type designation of the read head. In the section "Type Overview of WCS Read Head," you will find a detailed breakdown of the read head types, see chapter 11.

### Note

#### Information on security

From a security perspective, the following precautions must be taken for the product by the responsible application operator:

- Physically secure the device against unauthorized access
- Ensure that the device communicates only in an isolated bus with a higher-level controller and with a defined, trusted circuit of bus nodes

### 4.1 Electrical Connection and Data Cables

#### Caution!

Property damage and system malfunctions due to incorrect pinout

Incorrect assignment of the wire pairs to the respective pins can result in property damage and system malfunctions.

- Note the assignment of the wire pairs to the pins as shown in the respective wiring diagrams.

#### Connection diagram for WCS2B read head

The WCS2B read head is connected via a 5-pin M12 plug.

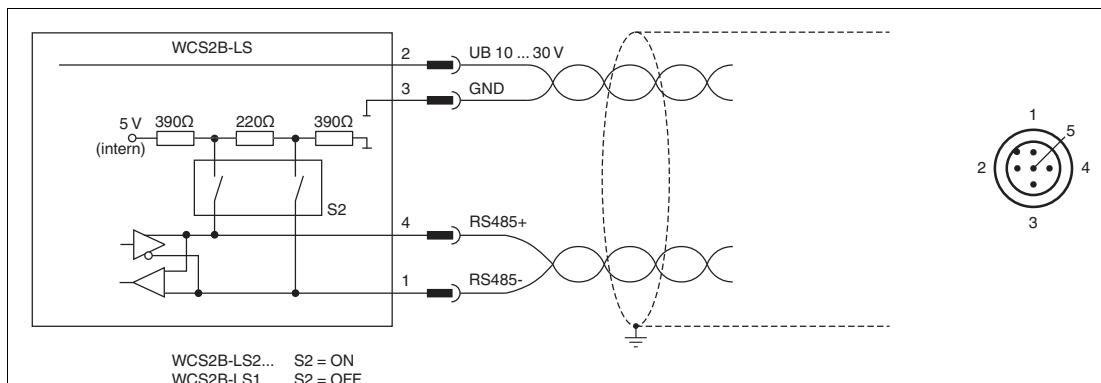

Figure 4.1 WCS2B, RS-485 interface



### Connection diagram for WCS3B read head

The WCS3B read head is connected via a 5-pin M12 plug.

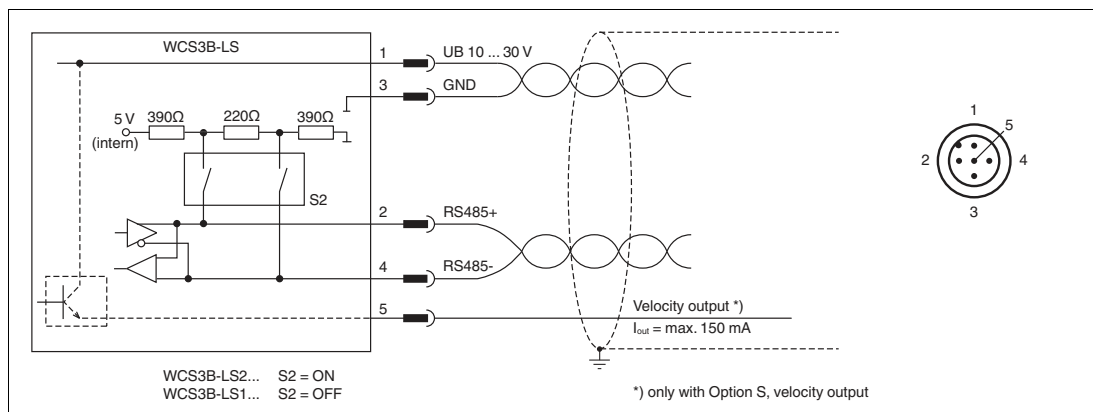

Figure 4.2 WCS3B, RS-485 interface

The counterpart of the plug connections, the 5-pin M12 socket, is not included in the scope of delivery for the read head. You can obtain suitable connectors and cables from Pepperl+Fuchs, see chapter 13.1.

### Data cable

For the RS-485 data transfer path, a four-wire, shielded, twisted pair data cable must be used. One wire pair is used for the supply voltage, and one pair for the RS-485 data connection. The maximum length of the cable depends on the capacitance of the data cable—core-core—for data transfer, and on the cross section of the cables for power supply to the read heads. For data transfer, a small core cross section and thus a small cable capacitance is an advantage, whereas for the power supply, the largest possible cross section is required. The table below shows the possible cable lengths depending on the cable cross section.

### Cable length

Cable cross section	AWG <sup>1</sup>	Number of read heads without heater				Number of read heads with heater			
		1	2	3	4	1	2	3	4
0.14 mm <sup>2</sup>	~ 26	200 m	110 m	70 m	50 m	15 m	10 m	7 m	5 m
0.22 mm <sup>2</sup>	~ 24	320 m	170 m	110 m	80 m	30 m	15 m	10 m	7 m
0.25 mm <sup>2</sup>	-	350 m	190 m	130 m	90 m	35 m	17 m	12 m	8 m
0.28 mm <sup>2</sup>	-	400 m	220 m	150 m	110 m	40 m	20 m	15 m	10 m
0.34 mm <sup>2</sup>	~ 22	500 m	250 m	180 m	140 m	50 m	25 m	17 m	12 m
0.50 mm <sup>2</sup>	~ 20	500 m	400 m	270 m	200 m	70 m	35 m	25 m	17 m

1. American Wire Gauge, a system commonly used in North America for the specification of wire diameters in electrical engineering.

In the calculations, the worst-case scenario was assumed: All read heads are located at the end of the data line. In the case of large cable lengths, and when connecting multiple WCS2 read heads with a heater, 6-wire data cables (3 x 2) can be used. These data cables use two pairs for the power supply (doubling the cable cross section), and one pair for the RS-485 data line. The table below shows the possible cable lengths depending on the cable capacitance (core-core). The number of connected read heads is of no significance.

Capacitance (core-core)	RS-485 interface		
	19.2 kb	62.5 kb	187.5 kb
60 pF	500 m	500 m	300 m
90 pF	500 m	450 m	275 m
120 pF	500 m	400 m	250 m

## 4.2 Hardware Configuration

You can change the hardware and software configuration of the read head in the read head. The changes to the read head type are made with two DIP switches or with three if you have a read head with the "Display" option: S1 (1) is a DIP switch with four switch positions, S2 (2) and S1D (3) are switches with two switch positions each.

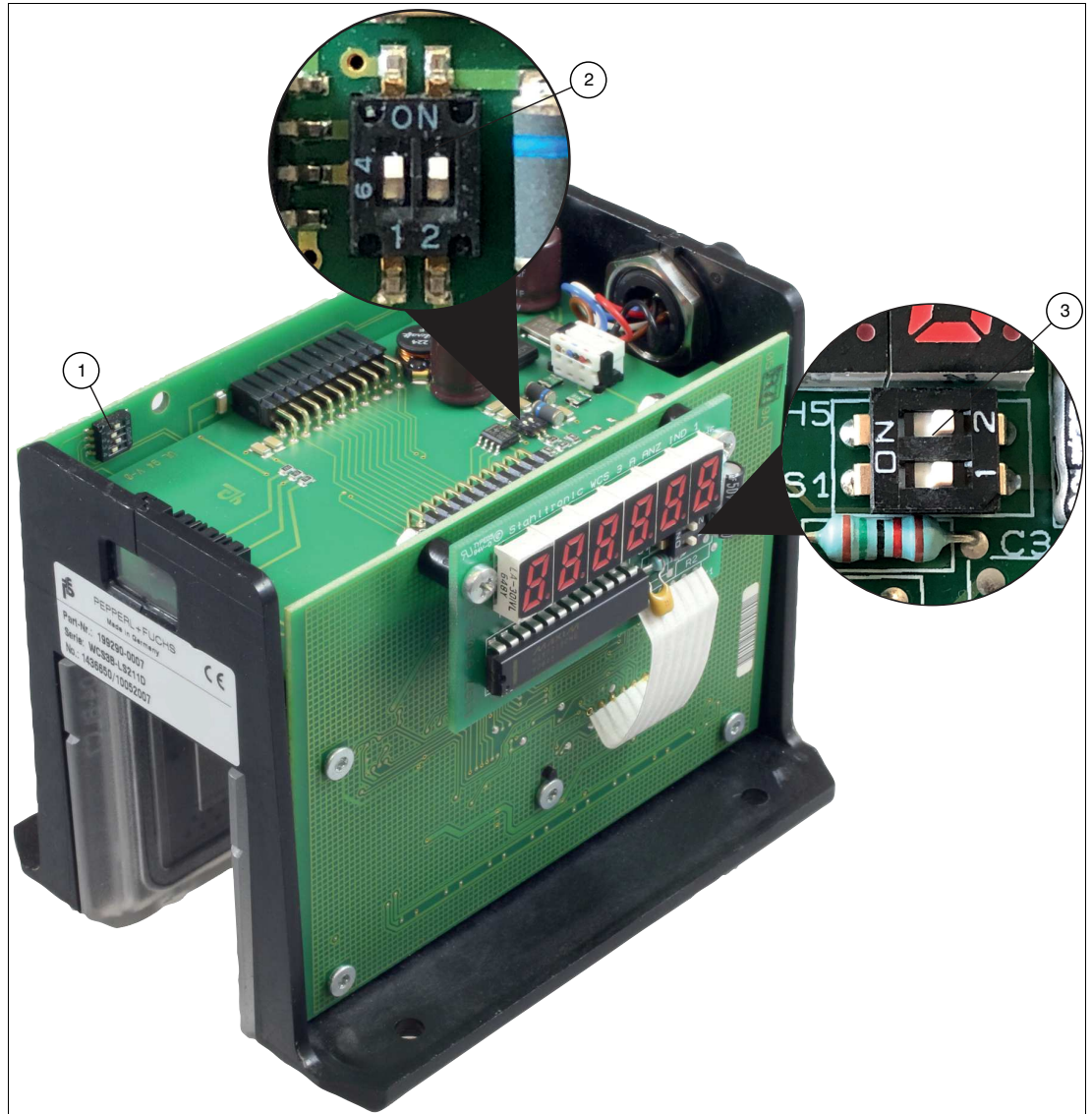

Figure 4.3 Positions of the DIP switches

1. Configuration switch S1, 4-way (address, baud rate)
2. Configuration switch S2, 2-way (terminator)
3. Configuration switch S1D, 2-way (display)

## Changing the read head address

Read head type	Configuration switch "S1"				Address
	1	2	3	4	
WCS2B-LS***-0 WCS3B-LS***-0	OFF	OFF	X	X	0
WCS2B-LS***-1 WCS3B-LS***-1	ON	OFF	X	X	1
WCS2B-LS***-2 WCS3B-LS***-2	OFF	ON	X	X	2
WCS2B-LS***-3 WCS3B-LS***-3	ON	ON	X	X	3
WCS3B-LS***S-0	OFF	X	X	X	0
WCS3B-LS***S-1	ON	X	X	X	1

## Changing the terminator

WCS2B and WCS3B		
Terminator	Configuration switch "S2"	
	1	2
ON	ON	ON
OFF	OFF	OFF

## Changing the baud rate

### Base types LS\*11/LS\*21:

Read head type (* = 1 or 2)	Configuration switch "S1"				Baud rate
	1	2	3	4	
WCS2B-LS*11 WCS3B-LS*11	X	X	OFF	X	187.5 kBaud
WCS2B-LS*21 WCS3B-LS*21	X	X	ON	X	62.5 kBaud

### Base types LS231/LS261

Read head type (* = 1 or 2)	Configuration switch "S1"				Baud rate
	1	2	3	4	
WCS2B-LS*61 WCS3B-LS*61	X	X	OFF	X	38.4 kBaud
WCS2B-LS*31 WCS3B-LS*31	X	X	ON	X	31.25 kBaud

### Base types LS246/LS256

Read head type (* = 1 or 2)	Configuration switch "S1"				Baud rate
	1	2	3	4	
WCS2B-LS*46 WCS3B-LS*46	X	X	OFF	OFF	19.2 kBaud even parity
WCS2B-LS*47 WCS3B-LS*47	X	X	OFF	ON	19.2 kBaud no parity

Read head type (* = 1 or 2)	Configuration switch "S1"				Baud rate
	1	2	3	4	
WCS2B-LS*56 WCS3B-LS*56	X	X	ON	OFF	9.6 kBaud even parity
WCS2B-LS*57 WCS3B-LS*57	X	X	ON	ON	9.6 kBaud no parity

**Base types LS\*1xS/LS\*2xS**

Read head type (* = 1 or 2, x = 1, 6, or 7)	Configuration switch "S1"				Baud rate
	1	2	3	4	
WCS3B-LS*1xS	X	OFF	X	X	187.5 kBaud
WCS3B-LS*2xS	X	ON	X	X	62.5 kBaud

**Base types LS\*3xS/LS\*6xS**

Read head type (* = 1 or 2, x = 1, 6, or 7)	Configuration switch "S1"				Baud rate
	1	2	3	4	
WCS3B-LS*6xS	X	OFF	X	X	38.4 kBaud
WCS3B-LS*3xS	X	ON	X	X	31.25 kBaud

**Base types LS\*3xS/LS\*6xS**

Read head type (* = 1 or 2, x = 1, 6, or 7)	Configuration switch "S1"				Baud rate
	1	2	3	4	
WCS3B-LS*4xS	X	OFF	X	X	19.2 kBaud
WCS3B-LS*5xS	X	OFF	X	X	9.6 kBaud

**Adjusting the Display**

You can rotate the character position on the display 180° using the S1D DIP switch. This allows you to read the displayed values easily regardless of the installation position of the read head.

WCS3B			
Display position	Configuration switch "S1D"		Comment
	1	2	
0°	OFF	OFF	The displayed value can be read on a code rail mounted upright.
180°	ON	ON	The displayed value can be read on a code rail mounted suspended.

### 4.3 Data Protocols

Various data protocols and data transmission speeds are available for direct connection of the read head to the higher-level control panel via a serial communication channel. The data protocols and baud rates are identical for the respective types in the WCS2B and WCS3B read heads.

A byte has the following format:

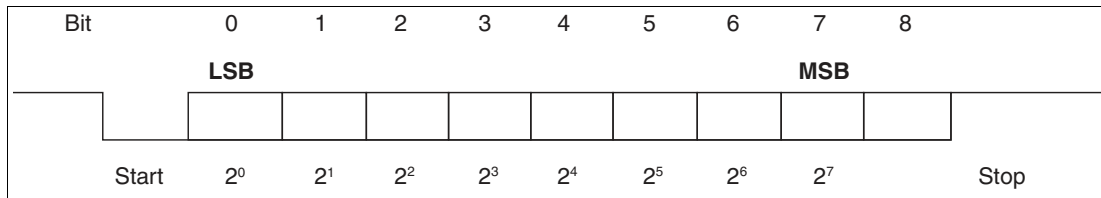

Figure 4.4 Data structure

For data protocols 1 and 2, the eighth data bit is used to distinguish between request bytes and response bytes. For control panels that do not support direction control via the eighth data bit, data protocol 3 is available. Read heads with an RS-485 interface and data protocol 3 can be delivered as type:

LSxx6 = data protocol 3 with parity (even parity), 9 bits/byte

LSxx7 = data log 3 without parity, 8 bits/byte

#### Response Time

The minimum response time of the read head (to start sending the first data bytes from the response telegram) depends on the internal time sequence of the read head and is 10 ... 180 µsec for data protocol 1 and 2.

For data protocol 3, the response time is a byte time + 10 ... 100 µsec. The byte time depends on the baud rate and is calculated from  $1/\text{baud rate} * 11,000$  in µsec.

For example: **38.4 kBaud**

Byte time =  $1/38.4 * 11,000 = 286.5$  µsec.

#### Note

Note the different data protocols for extended read head, see chapter 10.2.

### Data protocol 1

Request byte for read head									
Byte	Bit 8	Bit 7	Bit 6	Bit 5	Bit 4	Bit 3	Bit 2	Bit 1	Bit 0
	1	0	0	0	F0	0	0	A1	A0

Response telegram from the read head									
Byte	Bit 8	Bit 7	Bit 6	Bit 5	Bit 4	Bit 3	Bit 2	Bit 1	Bit 0
Byte 1	0	OUT	ERR	A1	A0	DB	P18	P17	P16
Byte 2	0	P15	P14	P13	P12	P11	P10	P09	P08
Byte 3	0	P07	P06	P05	P04	P03	P02	P01	P00
Byte 4	0	OUT	ERR	A1	A0	DB	P18	P17	P16
Byte 5	0	P15	P14	P13	P12	P11	P10	P09	P08
Byte 6	0	P07	P06	P05	P04	P03	P02	P01	P00

**Data protocol 1 with position and velocity output**

Request byte for read head									
Byte	Bit 8	Bit 7	Bit 6	Bit 5	Bit 4	Bit 3	Bit 2	Bit 1	Bit 0
	1	1	0	0	0	0	0	A1	A0

Response telegram from the read head									
Byte	Bit 8	Bit 7	Bit 6	Bit 5	Bit 4	Bit 3	Bit 2	Bit 1	Bit 0
Byte 1	0	OUT	ERR	A1	A0	DB	P18	P17	P16
Byte 2	0	P15	P14	P13	P12	P11	P10	P09	P08
Byte 3	0	P07	P06	P05	P04	P03	P02	P01	P00
Byte 4	0	SST	SP6	SP5	SP4	SP3	SP2	SP1	SP0
Byte 5	0	OUT	ERR	A1	A0	DB	P18	P17	P16
Byte 6	0	P15	P14	P13	P12	P11	P10	P09	P08
Byte 7	0	P07	P06	P05	P04	P03	P02	P01	P00
Byte 8	0	SST	SP6	SP5	SP4	SP3	SP2	SP1	SP0

**Data protocol 2**

Request byte for read head									
Byte	Bit 8	Bit 7	Bit 6	Bit 5	Bit 4	Bit 3	Bit 2	Bit 1	Bit 0
	1	0	1	1	F0	0	0	A1	A0

Response telegram from the read head									
Byte	Bit 8	Bit 7	Bit 6	Bit 5	Bit 4	Bit 3	Bit 2	Bit 1	Bit 0
Byte 1	0	OUT	ERR	A1	A0	DB	P18	P17	P16
Byte 2	0	P15	P14	P13	P12	P11	P10	P09	P08
Byte 3	0	P07	P06	P05	P04	P03	P02	P01	P00
Byte 4	0	Exclusive or link, byte 1 ... Byte 3							

**Data protocol 2 with position and velocity output**

Request byte for read head									
Byte	Bit 8	Bit 7	Bit 6	Bit 5	Bit 4	Bit 3	Bit 2	Bit 1	Bit 0
	1	1	1	1	0	0	0	A1	A0

Response telegram from the read head									
Byte	Bit 8	Bit 7	Bit 6	Bit 5	Bit 4	Bit 3	Bit 2	Bit 1	Bit 0
Byte 1	0	OUT	ERR	A1	A0	DB	P18	P17	P16
Byte 2	0	P15	P14	P13	P12	P11	P10	P09	P08
Byte 3	0	P07	P06	P05	P04	P03	P02	P01	P00
Byte 4	0	SST	SP6	SP5	SP4	SP3	SP2	SP1	SP0
Byte 5	0	Exclusive or link, byte 1 ... Byte 4							

### Data protocol 3

Request byte for read head									
Byte	Bit 8	Bit 7	Bit 6	Bit 5	Bit 4	Bit 3	Bit 2	Bit 1	Bit 0
	PAR	1	0	0	F0	0	0	A1	A0

Response telegram from the read head									
Byte	Bit 8	Bit 7	Bit 6	Bit 5	Bit 4	Bit 3	Bit 2	Bit 1	Bit 0
Byte 1	PAR	0	0	A1	A0	0	DB	OUT	ERR
Byte 2	PAR	0	0	0	P18	P17	P16	P15	P14
Byte 3	PAR	0	P13	P12	P11	P10	P09	P08	P07
Byte 4	PAR	0	P06	P05	P04	P03	P02	P01	P00
Byte 5	PAR	Exclusive or link, byte 1 ... Byte 4							

### Data protocol 3 with position and velocity output

Request byte for read head									
Byte	Bit 8	Bit 7	Bit 6	Bit 5	Bit 4	Bit 3	Bit 2	Bit 1	Bit 0
	PAR	1	1	1	0	0	0	A1	A0

Response telegram from the read head									
Byte	Bit 8	Bit 7	Bit 6	Bit 5	Bit 4	Bit 3	Bit 2	Bit 1	Bit 0
Byte 1	PAR	0	SST	A1	A0	0	DB	OUT	ERR
Byte 2	PAR	0	0	0	P18	P17	P16	P15	P14
Byte 3	PAR	0	P13	P12	P11	P10	P09	P08	P07
Byte 4	PAR	0	P06	P05	P04	P03	P02	P01	P00
Byte 5	PAR	0	SP6	SP5	SP4	SP3	SP2	SP1	SP0
Byte 6	PAR	Exclusive or link, byte 1 ... Byte 5							

### Description of the protocol data

#### Activation of the read head

F0	A1	A0	Read head address
x	0	0	Read head address 0
x	0	1	Read head address 1
x	1	0	Read head address 2
x	1	1	Read head address 3
0	x	x	Send position value
1	x	x	Send diagnostic result



**Data from read head**

Function number for read head F0=0 (send position value)					
ERR	DB	OUT	SST	Description	State of the read head lens
0	0	0	x	Current position value in P00 ... P18, binary coded	Good
0	0	1	x	Read head outside the code rail, no position value (see OUT message)	Good
0	1	0	x	Current position value in P00 ... P18, binary coded	Poor
0	1	1	x	No position value, read head outside the code rail (see OUT message)	Poor
1	x	x	x	No position value, error message from read head, error number in P00 ... P04, binary coded	-
x	x	x	1	Current speed unknown, last speed in SP0 ... SP6 *)	-
x	x	x	0	Current speed in SP0 ... SP6 *)	-

\*) Speed information

The speed is binary coded in bits SP0 to SP6.

SP0...SP6...	Speed in 0.1 m/s, binary coded
0:	Speed less than 0.1 m/s
126:	Speed more than 12.5 m/s
127:	Speed unknown

For example:

SP0...SP6...	1:	Speed 0.1 m/s
	37:	Speed 3.7 m/s
	112:	Speed 11.2 m/s

**Diagnostic function F0=1**

The read head can be requested to perform a diagnosis of the photoelectrics via the request byte to the read head. For this purpose, the read head must be located outside of the code rail. On the WCS2B and WCS3B read heads, the degree of dirt accumulation on the photoelectrics is monitored automatically during operation and the diagnostic bit (DB) set if dirt accumulation is too high. Thus the request for diagnosis to the read head via F0 in the request byte is no longer necessary. However, for reasons of downward compatibility, this function is also supported by the new read heads.

## Diagnostic bit (DB)

Diagnostic bit (DB) displays the result of the integrated diagnostics of the read head.

Function number for read head F0 = 1 (send diagnosis result)				
ERR	DB	OUT	Description	State of the read head lens
0	1	0	Diagnosis invalid, read head not outside of the code rail	-
0	1	1	Diagnosis result in P16 ... P18	-
			P16 ... P18 = 0	Good
			P16 ... P18 > 0	Poor
1	x	x	Error message from read head, error message in P00 ... P04, binary coded	-

## Contamination detection

Read heads WCS2B and WCS3B continually monitor the condition of the lenses. If a drop in light output is detected on the infrared transmitter, e.g., as a result of contamination of the clear protective lenses, the read head automatically increases the light intensity. If the level of contamination is too high, a warning message is sent to the higher-level control panel (diagnostic bit DB=1). The automatic light adjustment in the read head allows you sufficient time to clean the read head as part of the next servicing procedure. The WCS3B read head emits a visual signal for the "contamination detected" state: the yellow and red LEDs on the front of the read head flash alternately. To clean the lenses, the read head must be removed from the code rail (removed from the mounting base). After cleaning the transparent protective lenses, the contamination message is automatically deleted from the read head. If the message is not reset despite careful cleaning or replacement of the plastic protective lenses, there may be an error. In this case, the read head must be sent for inspection.

### OUT message

Function number for read head F0 = 0 (send position value)					
ERR	DB	OUT	SST	Description	State
0	x	1	x	P00...P18 = 0 -> read head is partially outside the code rail	OUT
				P00 = 1, P02...P18 = 0 -> read head is completely outside the code rail	OUT A

**OUT** means that the position value cannot be determined because the position of the code rail in the read head gap is incorrect.

**OUT A** (A=All) means that there is no code rail in the read head gap; all light barriers of the read head report a signal.

The "OUT" message may be desirable and correct, e.g., if the code rail is interrupted and the read head sends this information between the individual rail pieces to the control panel. If the "OUT" message must not occur, the following test steps must be performed:

Result of the check	Remedy
The upper edge of the code rail is outside the tolerance range of the read head	<ul style="list-style-type: none"> <li>Align the code rail precisely</li> <li>Aligning the read head</li> <li>Use the guide system for the read head</li> </ul>
The plastic protective lenses on the optical unit are dirty or scratched	<ul style="list-style-type: none"> <li>Clean optical unit</li> <li>Ensure the read head is cleaned</li> <li>Change the protective lenses</li> </ul>
Incidence of extraneous light	<ul style="list-style-type: none"> <li>Protect the read head against any incidence of extraneous light</li> </ul>

If these measures do not solve the problem, the read head must be sent for inspection.

## 4.4 Status and Error Messages

Error number	Cause	Remedy
1 2	WCS read head cannot calculate position value because:	
	Optical unit is dirty	Clean optical unit
	Plastic protective lenses are scratched	Align WCS read head and code rail correctly; replace scratched plastic protective lenses
	Position of the read head in relation to the code rail is incorrect	Check the position of the WCS read head in relation to the code rail; install WCS read head correctly
	Light barriers have failed	Check light barriers; if necessary send for repair
3	RAM error, WCS read head	Send WCS read head for repair
4	EPROM error, WCS read head	Send WCS read head for repair
5	ROM error, WCS read head	Send WCS read head for repair
6	Reserved	
7	No position value available	Message only after switching on the WCS read head and/or after a RESET
8 9 10 11 12	Data transfer error between WCS read head and interface module, data transfer disrupted	Check the cable connection from the WCS read head to the interface module; check the shielding, protective earth, cable routing (EMC)
13	WCS read head cannot be addressed by the interface module	Check the cable connection from the WCS read head to the interface module; check the operating voltage of the read head
14	Read head is located in the initialize or diagnostic routine	Wait for initialization; exit diagnostics (set the selector switch on the interface module to 0 ... 7)
15	Interface module is not set for communication with multiple WCS read heads	Send interface module for correct configuration setting
19	RAM error in interface module	Send interface module for repair
20	EPROM error in interface module	Send interface module for repair

## 4.5 LED Status Indication

WCS3B-LS1xx\*/ WCS3B-LS2xx\*

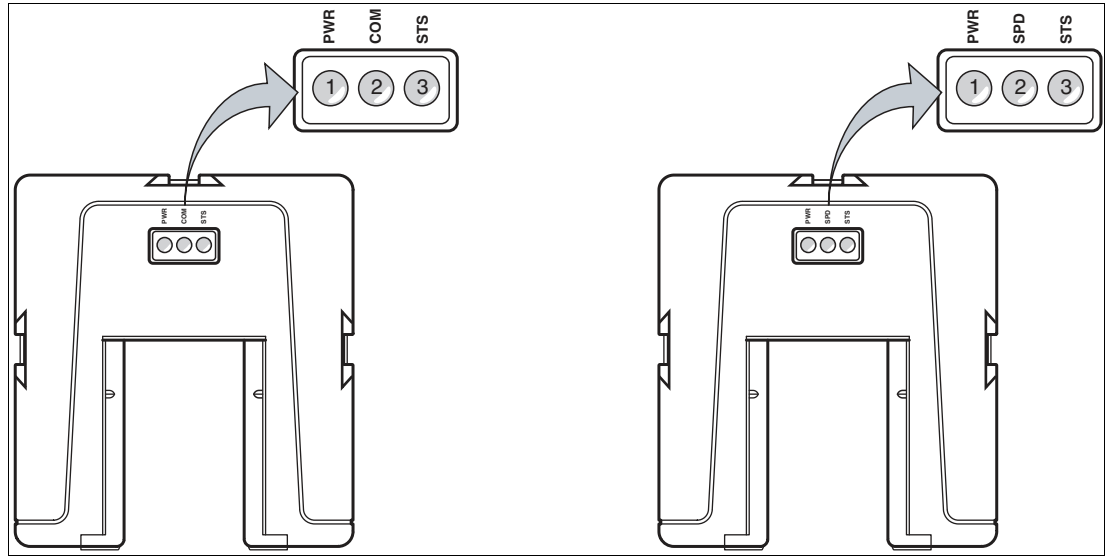

### Description of the LED Indicators

Item	Display	Designation	Color	Display	Meaning
1	PWR	Operating Indicator	green	On	Power on
2 (left)	COM	Data flow indicator	Yellow	On	Data transfer active
2 (right)	SPD	Velocity display	Yellow	On	When the limit speed is exceeded
3	STS	Fault indicator	red	On	System error
			red	Flashing	Read head outside the code rail
2 and 3	STS and SPD, or COM	Contamination indicator	yellow and red	Flash alternately (f=1.5 Hz)	The read head optics are dirty
		Function indicator	yellow and red	for 2 secs	After switching on or a reset

**WCS3B-LS\*E\* (Option—Extended)**

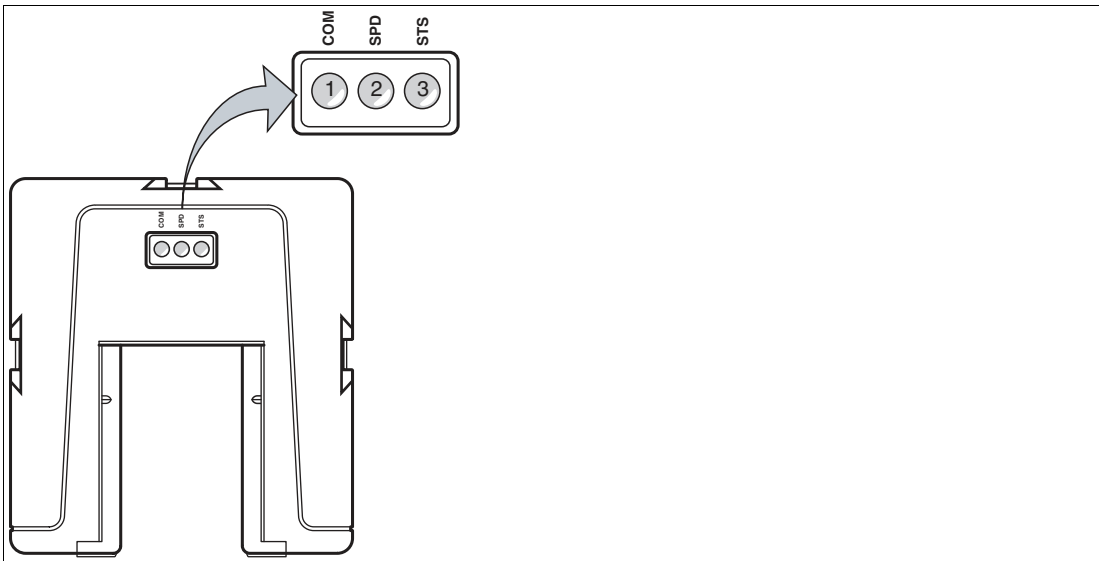

**Description of the LED Indicators**

Item	Display	Designation	Color	Display	Meaning
1	COM	Data flow indicator	Yellow	Flashing	Data transfer active
			Yellow	Off	Data transfer indicator
2	SPD	Velocity display	Yellow	On	Supply voltage on
			Yellow	Off	Limit speed exceeded
3	STS	Status indicator	green	On	Code rail detected, normal function
			green	Flashing	Position invalid; code rail area is not unique after the supply voltage has been connected
			red	On	Internal diagnostic error
			red	Flashing	Read head partially or completely outside the code rail

## 5 SSI Interface (LS3xx\*)

The read head with SSI interface supports data formats in Gray code (LS311) or binary code (LS310). Data transfer is carried out on the SSI read head at the request of the control panel.



### Note

#### Information on security

From a security perspective, the following precautions must be taken for the product by the responsible application operator:

- Physically secure the device against unauthorized access
- Make sure there is a point-to-point connection between the device and the higher-level controller

### 5.1 Electrical Connection and Data Cables



#### Caution!

Property damage and system malfunctions due to incorrect pinout

Incorrect assignment of the wire pairs to the respective pins can result in property damage and system malfunctions.

- Note the assignment of the wire pairs to the pins as shown in the respective wiring diagrams.

#### Connection diagram for WCS2B read head

The WCS2B read head with SSI interface is electrically connected via an 8-pin M12 plug.

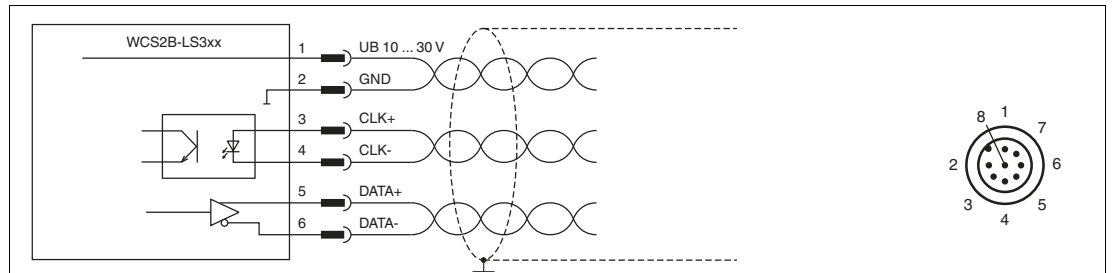

Figure 5.1 WCS2B, SSI interface

#### Connection diagram for WCS3B read head

The WCS3B read head with SSI interface is electrically connected via an 8-pin M12 plug.

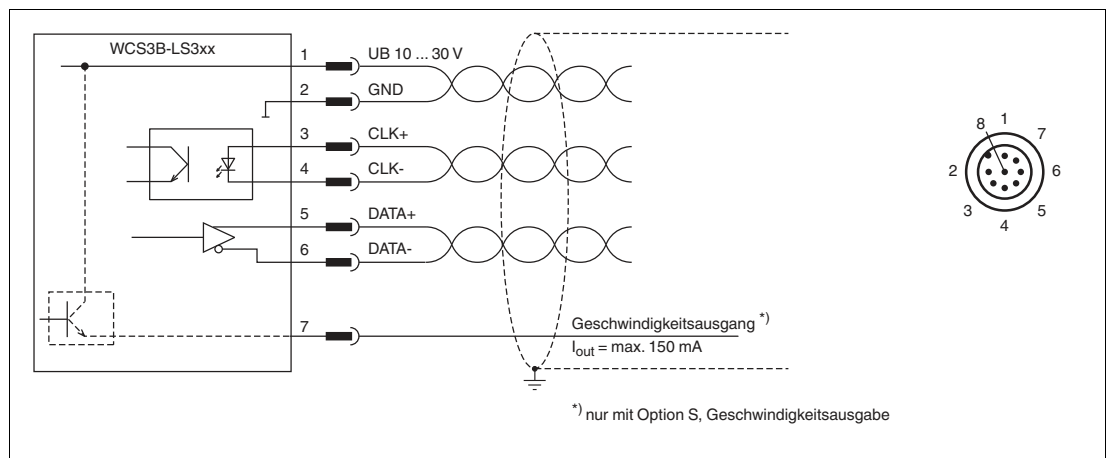

Figure 5.2 WCS3B, SSI interface

The counterpart of the plug connections, the 8-pin M12 socket, is not included in the scope of delivery for the respective read head. You can obtain suitable connectors and cables from Pepperl+Fuchs, see chapter 13.1.

### Data cable

For SSI data transfer, a 6-wire, shielded, twisted pair data cable (3 x 2) is used. One wire pair is used for the supply voltage, one pair for the CLK line, and one pair for the DATA line. The cable lengths that are technically possible can be determined from the tables. For large cable lengths (longer than 12 m) between the SSI read head and control panel, we recommend using the SSI interface module. In this case, the data is transferred asynchronously from the read head to the interface module via the RS-485 interface. The data is converted to SSI protocol immediately next to the control panel. The table below shows the possible cable lengths depending on the cable capacitance (core-core). The number of connected read heads is of no significance.

Capacitance (core-core)	SSI Interface		
	125 kHz	250 kHz	500 kHz
60 pF	200 m	100 m	30 m
90 pF	150 m	80 m	25 m
120 pF	100 m	60 m	20 m



## 5.2 Hardware Configuration

You can change the hardware and software configuration of the read head in the read head. The changes to the read head type are made with a DIP switch or with two if you have a read head with the "Display" option: S1 (1) is a DIP switch with four switch positions and S1D (2) is a DIP switch with two switch positions.

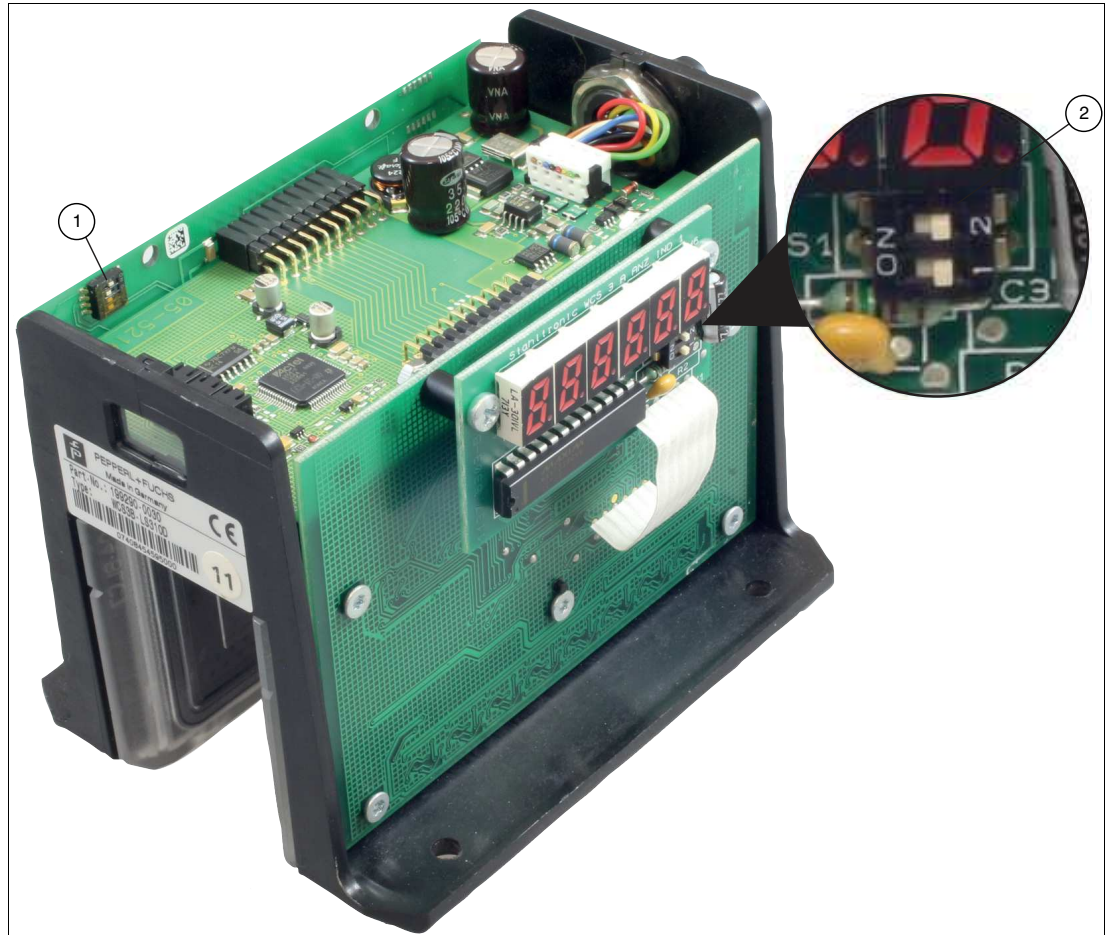

Figure 5.3 Configuration switch positions

1. Configuration switch S1, 4-way (data format, contamination detection)
2. Configuration switch S1D, 2-way (display)

### Changing the data format

Read head type	Configuration switch "S1"				Code
	1	2	3	4	
WCS2B-LS310 WCS3B-LS310	ON	OFF	X	X	Binary
WCS2B-LS311 WCS3B-LS311	OFF	OFF	X	X	Gray

### Output of a warning if the lenses are contaminated

Read head type	Configuration switch "S1"				Code
	1	2	3	4	
WCS2B-LS31* WCS3B-LS31*	X	OFF	X	OFF	ON
WCS2B-LS31* WCS3B-LS31*	X	OFF	X	ON	OFF

### Adjusting the Display

You can rotate the character position on the display 180° using the S1D DIP switch. This allows you to read the displayed values easily regardless of the installation position of the read head.

WCS3B			
Display position	Configuration switch "S1D"		Comment
	1	2	
0°	OFF	OFF	The displayed value can be read on a code rail mounted upright.
180°	ON	ON	The displayed value can be read on a code rail mounted suspended.

## 5.3 Data Protocols

The read head with SSI interface supports data formats in gray code (LS311) or binary code (LS310). Data transfer for the SSI read head is carried out on request from the control panel.

### SSI interface

The clock signal (CLK) generated by the control panel is used for the transfer. If no data transfer begins, the serial data output of the read head remains at 1. The data transfer begins with a falling edge of the clock signal. With each rising edge of the clock signal, the read head transmits one bit of the current position. The transfer begins with the most significant bit (MSB) and ends with the least significant bit (LSB).

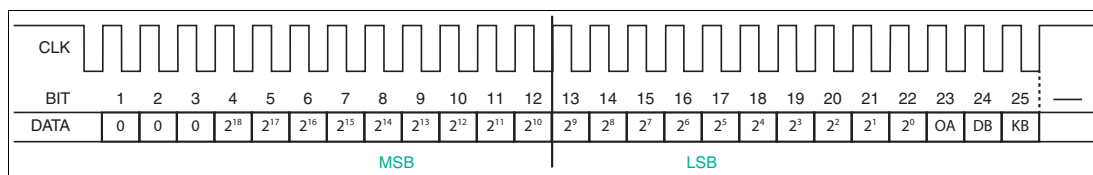

Figure 5.4 SSI data format

The read head with SSI interface corresponds to a 19-bit absolute encoder in the data format. Effectively, the WCS read head delivers up to 512 revolutions and 1024 increments/revolution. The clock rate between the control panel and the read head may be 100 ... 1000 kHz. The recommended value is 250 kHz.

### Bit 1 ... 3

The first three bits are always 0.

### Bit 4 ... 22 ( $2^{18}$ ... $2^0$ position values)

The position values are transferred to bits 4 to 22 of the SSI protocol. For LS311 read heads the position values are gray encoded, and for LS310 read heads the position values are binary encoded.

### Bit 23 (OA read head outside the code rail)

A distinction is made between two different states:

1. The code rail is located in the read head gap, but outside the possible tolerances. In this case, the control panel receives the following bit pattern:  
 KB = 0  
 OA = 0  
 POS  $2^0$  ...  $2^{18}$  = 1 (position value 524287)
2. There is no code rail in the read head gap. In this case, bit OA = 1 (Out All) is set in addition to the above bit pattern.



### Note

Position data (bit 4 ... 22) are output for LS311 read heads in gray code. Status and error bits (bit 23 ... 25) are not output in gray code.

### Bit 24 (DB output of a prewarning if the lenses are contaminated)

The contamination warning is transferred in bit 24 of the SSI protocol and can be evaluated. The diagnostic bit DB is always switched on by default.

Read heads WCS2B and WCS3B continually monitor the condition of the lenses. If a drop in light output is detected on the infrared transmitter, e.g., as a result of contamination of the clear protective lenses, the read head automatically increases the light intensity. If the level of contamination is too high, a warning message is sent to the higher-level control panel (diagnostic bit DB=1). The automatic light adjustment in the read head allows you sufficient time to clean the read head as part of the next servicing procedure. The WCS3B read head emits a visual signal for the "contamination detected" state: the yellow and red LEDs on the front of the read head flash alternately. To clean the lenses, the read head must be removed from the code rail (removed from the mounting base). After cleaning the transparent protective lenses, the contamination message is automatically deleted from the read head. If the message is not reset despite careful cleaning or replacement of the plastic protective lenses, there may be an error. In this case, the read head must be sent for inspection.

Read head type (* = 0 or 1)	S1				Diagnostic bit
	1	2	3	4	
WCS2B-LS31*	X	OFF	X	OFF	ON
WCS2B-LS31*	X	OFF	X	ON	OFF
WCS3B-LS31*	X	OFF	X	OFF	ON
WCS3B-LS31*	X	OFF	X	ON	OFF

### Bit 25 (KB error message)

If the read head detects an error, the KB error bit is set and the error code is output to the control panel:

KB = 1

POS  $2^0$  ...  $2^2$  = error number

POS  $2^3$  ...  $2^{18}$  = 0

Information on the error messages see chapter 5.4.

## 5.4 Status and Error Messages

Error number	Cause	Remedy
1 2	WCS read head cannot calculate position value because:	
	Optical unit is dirty	Clean optical unit
	Plastic protective lenses are scratched	Align WCS read head and code rail correctly; replace scratched plastic protective lenses
	Position of the read head in relation to the code rail is incorrect	Check the position of the WCS read head in relation to the code rail; install WCS read head correctly
	Light barriers have failed	Check light barriers; if necessary send for repair
3	RAM error, WCS read head	Send WCS read head for repair
4	EPROM error, WCS read head	Send WCS read head for repair
5	ROM error, WCS read head	Send WCS read head for repair
6	Reserved	
7	No position value available	Message only after switching on the WCS read head and/or after a RESET

## 5.5 LED Status Indication

### WCS3B-LS3xx\*

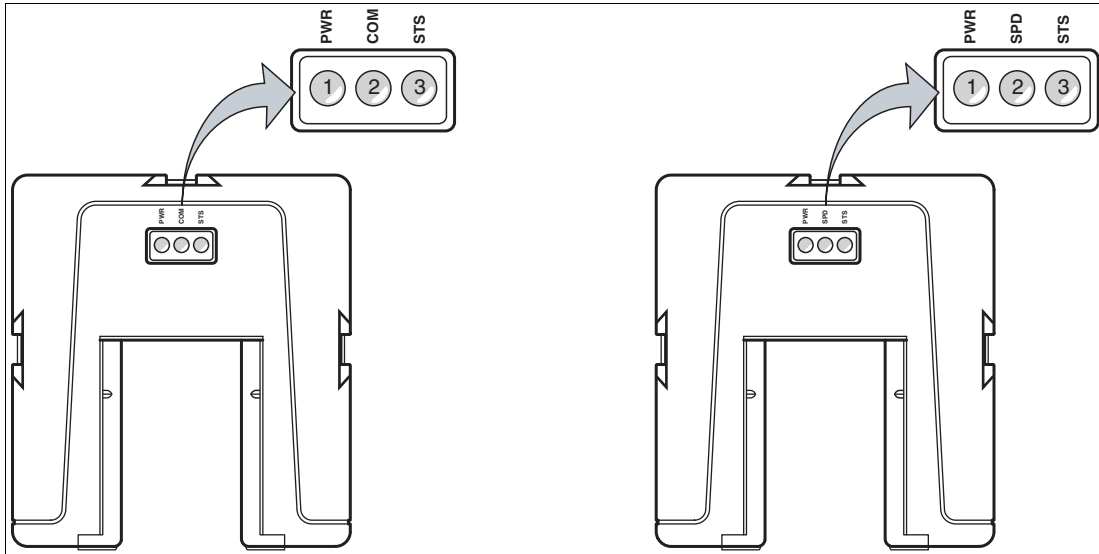

#### Description of the LED Indicators

Item	Display	Designation	Color	Display	Meaning
1	PWR	Operating Indicator	green	On	Power on
2 (left)	COM	Data flow indicator	Yellow	On	Data transfer active
2 (right)	SPD	Velocity display	Yellow	On	When the limit speed is exceeded
3	STS	Fault indicator	red	On	System error
			red	Flashing	Read head outside the code rail
2 and 3	STS and SPD, or COM	Contamination indicator	yellow and red	Flash alternately (f=1.5 Hz)	The read head optics are dirty
		Function indicator	yellow and red	for 2 secs	After switching on or a reset

## 6 CANopen Interface (LS4xx\*)

The WCS3B read head with CANopen interface can be connected directly to a CANopen bus after configuration. The configuration is carried out via DIP switches in the read head in a de-energized state.

The CAN interface is galvanically isolated. The read head works as a CANopen node in the "Predefined Connection Set" and sends the data in the TxPDO1.



### Note

#### Information on security

From a security perspective, the following precautions must be taken for the product by the responsible application operator:

- Physically secure the device against unauthorized access
- Ensure that the device communicates only in an isolated bus with a higher-level controller and with a defined, trusted circuit of bus nodes

### 6.1 Electrical Connection



#### Caution!

Property damage and system malfunctions due to incorrect pinout

Incorrect assignment of the wire pairs to the respective pins can result in property damage and system malfunctions.

- Note the assignment of the wire pairs to the pins as shown in the respective wiring diagrams.

#### Connection diagram for WCS3B read head

The connection is made via a 5-pin M12 plug. The counterpart to the connector is not included in the scope of delivery for the read head.

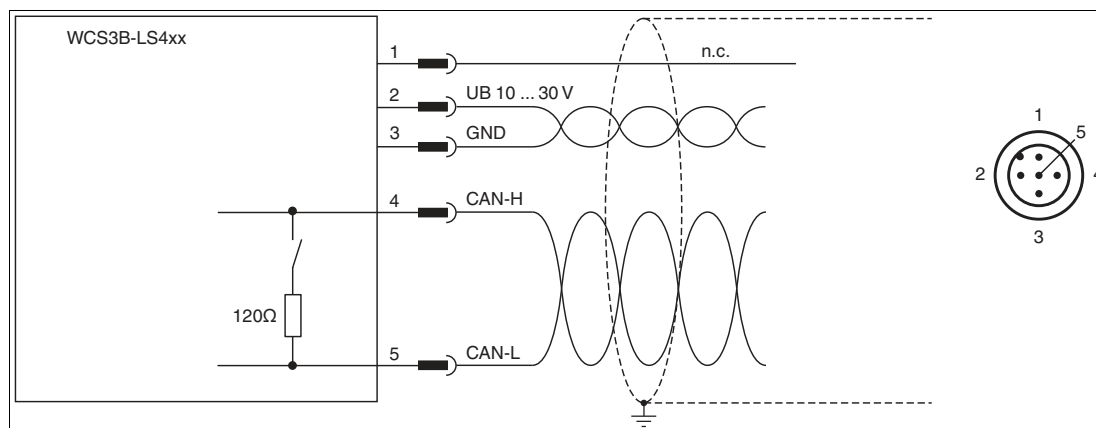

Figure 6.1 WCS3B, CANopen interface

You can obtain suitable connectors and cables from Pepperl+Fuchs, see chapter 13.1.

### Data cable

For CANopen data transfer, a four-wire, shielded, twisted pair data cable must be used. One wire pair is used for the supply voltage, and one wire pair is used for the CANopen data transfer.

The maximum length of the cable depends on the speed of the data transfer. The table below shows the possible cable lengths depending on the bit rate.

#### Maximum cable length

Bit rate	Cable length
125 kbits/s	500 m
250 kbits/s	250 m
500 kbits/s	100 m
1 Mbits/s	30 m



## 6.2 Hardware Configuration

You can change the hardware and software configuration of the read head in the read head. The read head type is changed using three DIP switches.



Figure 6.2 Configuration switch positions

1. 4-way configuration switch (transfer mode, data protocols)
2. 1-way configuration switch (CAN terminator)
3. 8-way configuration switch (baud rate, node ID)

### CAN terminator

On the middle PCB in the read head there is a 1-way DIP switch (2). This switch can be used to switch the CAN terminator, 120 ohms, off or on. The terminator is switched on by default.

## Baud rate

The baud rate can be changed using two switches of the 8-way DIP switch (3) on the central PCB in the read head. The baud rate is 250 kBaud by default.

DIP 8-8	DIP 8-7	Baud rate
OFF	OFF	125 kBaud
OFF	ON	250 kBaud
ON	OFF	500 kBaud
ON	ON	1 MBaud

## Node ID

The address in the CANopen bus, the node ID, can be changed using switches 1 to 6 of the 8-way DIP switch (3) on the central PCB in the read head. The node ID is encoded in binary form. The smallest possible node ID is 1, the highest possible node ID is 63. Node ID 0 is not permitted. Node ID 1 is applied by default.

## Transfer mode in the CANopen bus

The transfer mode and the "inhibit time" can be configured using switches 1 to 3 of the 4-way DIP switch (1) on the PCB on the side of the read head.

### Asynchronous

Switch position 0 ... 3, see table below.

The read head automatically sends the data to the CAN bus as soon as this has changed in the read head. However, a wait time of at least x ms must have passed since the last data packet. This can prevent bus overload. If x = 0 ms, no waiting time is taken into account. In this case, the maximum data rate to the CAN bus is approx. 1.5 ... 2 ms.

If the data in the read head does not change, it is sent to the CAN bus every y ms. Thus the control panel receives data even if the vehicle is stationary.

### Synchronous

Switch position 7, see table below.

The read head sends data after the SYNC command from the control panel. The typical delay time after SYNC is 2 ms; the maximum delay time is 5 ms. By default, switch 1 - 3 = OFF, i.e., asynchronous data transfer 0 ms/10 ms.

Switch setting	DIP4-3	DIP4-2	DIP4-1	x ms/y ms
0	OFF	OFF	OFF	0 ms/10 ms
1	OFF	OFF	ON	5 ms/20 ms
2	OFF	ON	OFF	10 ms/50 ms
3	OFF	ON	ON	20 ms/50 ms
4	ON	OFF	OFF	Reserved
5	ON	OFF	ON	Reserved
6	ON	ON	OFF	Reserved
7	ON	ON	ON	SYNC mode

## Data Protocols

Two data protocols are supported: CAN data protocol 1 and CAN data protocol 2.

The data protocols always have a length of 8 bytes. The data protocol is selected via the fourth switch of the 4-way DIP switch (1) on the PCB on the side of the read head.

DIP4-4 = OFF ... Can data protocol 1

DIP4-4 = ON ... CAN data protocol 2

## 6.3 Software Configuration

The read head is integrated into the network via an EDS file (electronic datasheet) with a project planning tool such as RSLogix 5000. The EDS file contains all information about device-specific parameters and operating modes.



### Note

#### Downloading the EDS file

You can find the relevant EDS file in the **Software** section of the product detail page for the device.

To access the product detail page for the device, go to <http://www.pepperl-fuchs.com> and type e.g., the product description or the item number into the search function.

## 6.4 Data Protocols

Two data protocols are supported: data protocol 1 and data protocol 2.

The data protocols always have a length of 8 bytes. The data protocol is selected via the fourth switch of the 4-way DIP switch on the PCB on the side of the read head (see chapter 6.2).

- DIP4-4 = OFF ... CAN data protocol 1
- DIP4-4 = ON ... CAN data protocol 2

### Data protocol 1

Bit	Bit 7	Bit 6	Bit 5	Bit 4	Bit 3	Bit 2	Bit 1	Bit 0
Byte 0	0	0	0	0	0	P18	P17	P16
Byte 1	P15	P14	P13	P12	P11	P10	P09	P08
Byte 2	P07	P06	P05	P04	P03	P02	P01	P00
Byte 3	0	0	SST	DB	ERR	OUT	0	0
Byte 4	0	SP6	SP5	SP4	SP3	SP2	SP1	SP0
Byte 5	0	0	0	0	0	0	0	0
Byte 6	0	0	0	0	0	0	0	0
Byte 7	0	0	0	0	0	0	0	0

### Data protocol 2

Bit	Bit 7	Bit 6	Bit 5	Bit 4	Bit 3	Bit 2	Bit 1	Bit 0
Byte 0	0	0	SST	DB	ERR	OUT	0	0
Byte 1	P07	P06	P05	P04	P03	P02	P01	P00
Byte 2	P15	P14	P13	P12	P11	P10	P09	P08
Byte 3	0	0	0	0	0	P18	P17	P16
Byte 4	0	SP6	SP5	SP4	SP3	SP2	SP1	SP0
Byte 5	0	0	0	0	0	0	0	0
Byte 6	0	0	0	0	0	0	0	0
Byte 7	0	0	0	0	0	0	0	0

## 6.5 LED Status Indication

### WCS3B-LS4xx\*

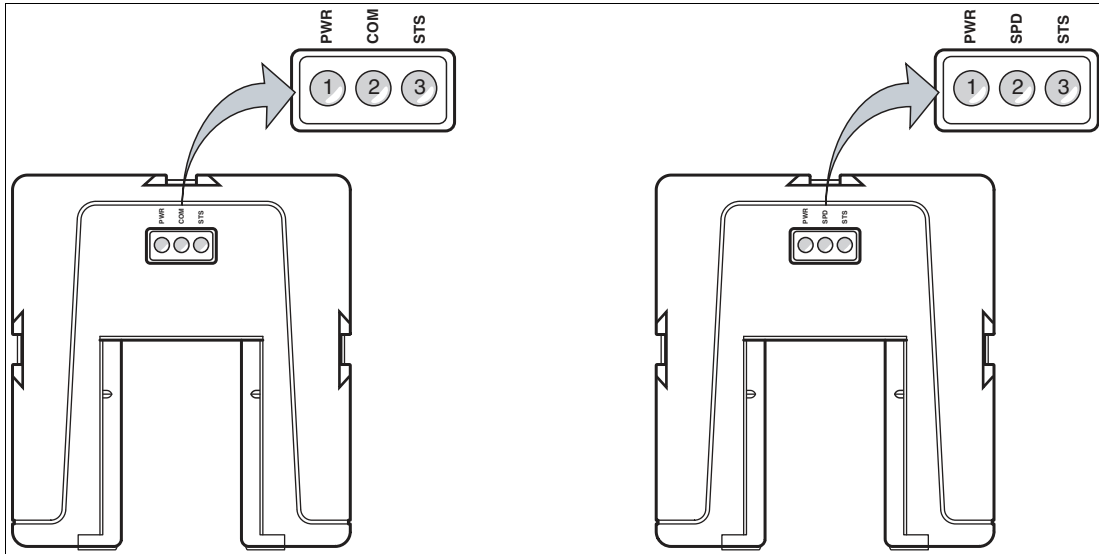

#### Description of the LED Indicators

Item	Display	Designation	Color	Display	Meaning
1	PWR	Operating Indicator	green	On	Power on
2 (left)	COM	Data flow indicator	Yellow	On	Data transfer active
2 (right)	SPD	Velocity display	Yellow	On	When the limit speed is exceeded
3	STS	Fault indicator	red	On	System error
			red	Flashing	Read head outside the code rail
2 and 3	STS and SPD, or COM	Contamination indicator	yellow and red	Flash alternately (f=1.5 Hz)	The read head optics are dirty
		Function indicator	yellow and red	for 2 secs	After switching on or a reset

## 7 EtherNet/IP Interface (LS5xx\*)

The read head communicates with the controller (e.g., PLC) via EtherNet/IP. An object-oriented fieldbus system for exchanging data between nodes based on Ethernet communications.

The basic properties of the interface are:

- Transfer rate 10 Mbit/s or 100 Mbit/s, half or full duplex operation
- Automatic negotiation of the transfer rate and the duplex method (auto negotiation)
- Automatic setting for crossed lines (auto crossover)

EtherNet/IP protocol works according to the CIP protocol (Common Industrial Protocol) and is used to control, configure, monitor, and collect data. Time-sensitive data exchange (implicit messaging) takes place using the UDP/IP protocol and non-time-sensitive data exchange (explicit messaging) using the TCP/IP protocol.

The read head supports the following features:

- "Listen only," "Input only," and "Exclusive Owner" connection types
- Message transmission as "Multipoint data transfer" (Multicast) and "Point-to-point data transfer" (Unicast)
- Cycle time (request packet interval)  $\geq 2$  ms
- Dynamic Host Configuration Protocol (DHCP)
- Address Conflict Detection (ACD)



---

### Note

#### Information on security

From a security perspective, the following precautions must be taken for the product by the responsible application operator:

- Physically secure the device against unauthorized access
  - Ensure that the device is only operated on an isolated network without connection to the corporate network, internet, or cloud services;
    - there the device may only communicate with a higher-level controller, or with a defined, trusted circle of network participants
  - Protect the power supply from unauthorized access:
    - The device has a recovery mode in which the firmware can be changed. The recovery mode is activated by lowering the input voltage to below 9 V!
    - Ensure an input voltage of at least 10 V in normal operation.
-

## 7.1 Electrical Connection



### Caution!

Property damage and system malfunctions due to incorrect pinout

Incorrect assignment of the wire pairs to the respective pins can result in property damage and system malfunctions.

- Note the assignment of the wire pairs to the pins as shown in the respective wiring diagrams.

### Connection diagram for WCS3B read head

The WCS3B-LS5\* read head is connected to EtherNet/IP and the power supply via an 8-pin M12 socket with Y encryption.

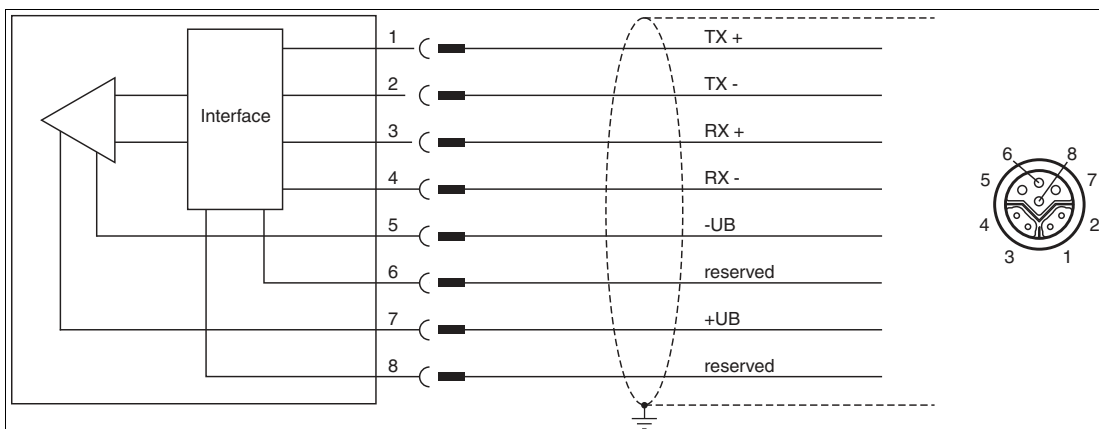

Figure 7.1 WCS3B, EtherNet/IP interface

Pins 6 and 8 are reserved for an internal interface and are connected to ground (-UB).

### Note

A shielded twisted pair cable that meets at least the CAT 5e/CAT 6 specification is used to connect the read head to the control panel. The maximum recommended cable length is 75 m for CAT 5e and 55 m for CAT 6. Longer distances are possible provided that the respective specifications are observed. The connection can be implemented with various cable types available from Pepperl+Fuchs.

### Y-splitter

There are various options available for the electrical connection. A hybrid cable (see chapter 13.1) with a common data and supply line can be connected directly to the read head. Alternatively, data and supply lines can be routed separately with the Y-splitter.

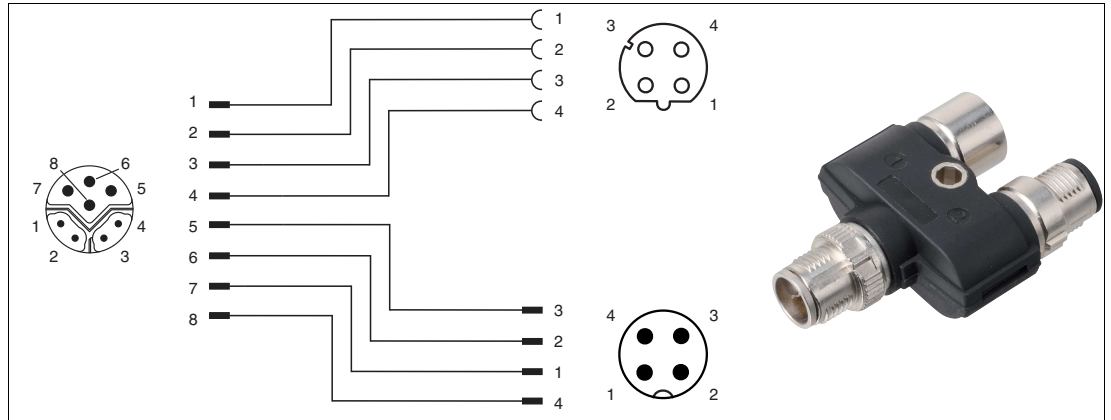

Figure 7.2 V19SY-Y-V1D/V1: Y-splitter, M12 plug Y-encoded to M12 plug A-encoded and M12 socket D-encoded

You can obtain the appropriate connectors and cables from Pepperl+Fuchs, see chapter 13.1.

## 7.2 Hardware Configuration

If you have a read head with the "Display" option, a DIP switch with two switches S1D (2) is installed. This DIP switch allows you to change the display. The 4-way DIP switch (1) in the figure below does not work. The firmware parameters of the read head are set via the corresponding project planning software.

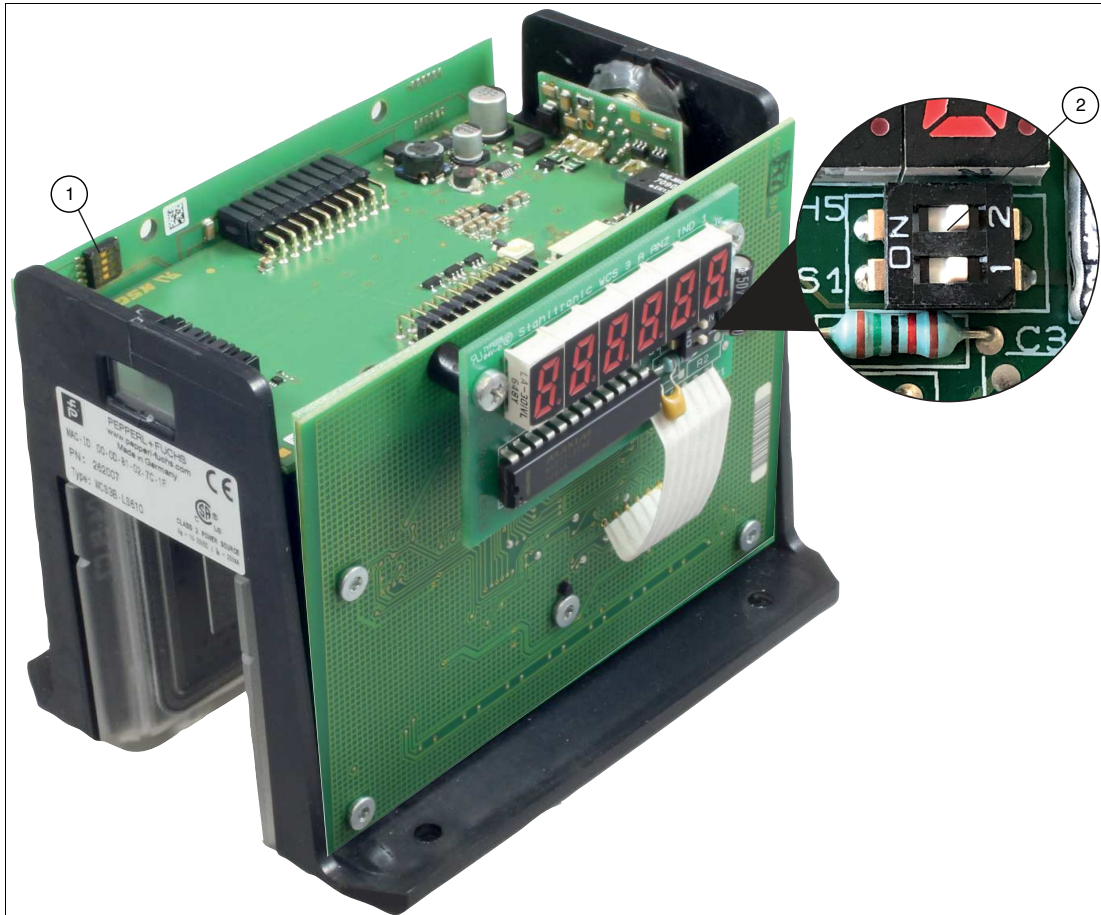

Figure 7.3 Configuration switch positions

1. Configuration switch S1, 4-way (no function)
2. Configuration switch S1D, 2-way (display)

### Adjusting the Display

You can rotate the character position on the display 180° using the S1D DIP switch. This allows you to read the displayed values easily regardless of the installation position of the read head.

WCS3B			
Display position	Configuration switch "S1D"		Comment
	1	2	
0°	OFF	OFF	The displayed value can be read on a code rail mounted upright.
180°	ON	ON	The displayed value can be read on a code rail mounted suspended.



## 7.3 Software Configuration

The read head communicates with the control panel (e.g., PLC) via EtherNet/IP, an object-oriented fieldbus system for exchanging data between nodes based on Ethernet communications.

The read head is integrated into the network via an EDS file (electronic datasheet) with a project planning tool such as RSLOGIX5000. The EDS file contains all information about device-specific parameters and operating modes.



### Note

#### Downloading the EDS file

You can find the relevant EDS file in the **Software** section of the product detail page for the device.

To access the product detail page for the device, go to <http://www.pepperl-fuchs.com> and type e.g., the product description or the item number into the search function.



### Setting the IP address

The read head is delivered in DHCP mode and waits for an address assignment from the control panel.

The following section describes the process of assigning an address via the **BOOT/DHCP Server** from Rockwell Automation as an example.

1. Connect the read head with the DHCP server.
2. Start the **BOOT/DHCP server** software.
3. Enter the following data in the **Network Settings** menu:
  - Subnet Mask "255.255.255.0"
  - Gateway "192.168.1.1"
  - The remaining fields are not filled in.

4. Switch on the supply voltage to the read head.

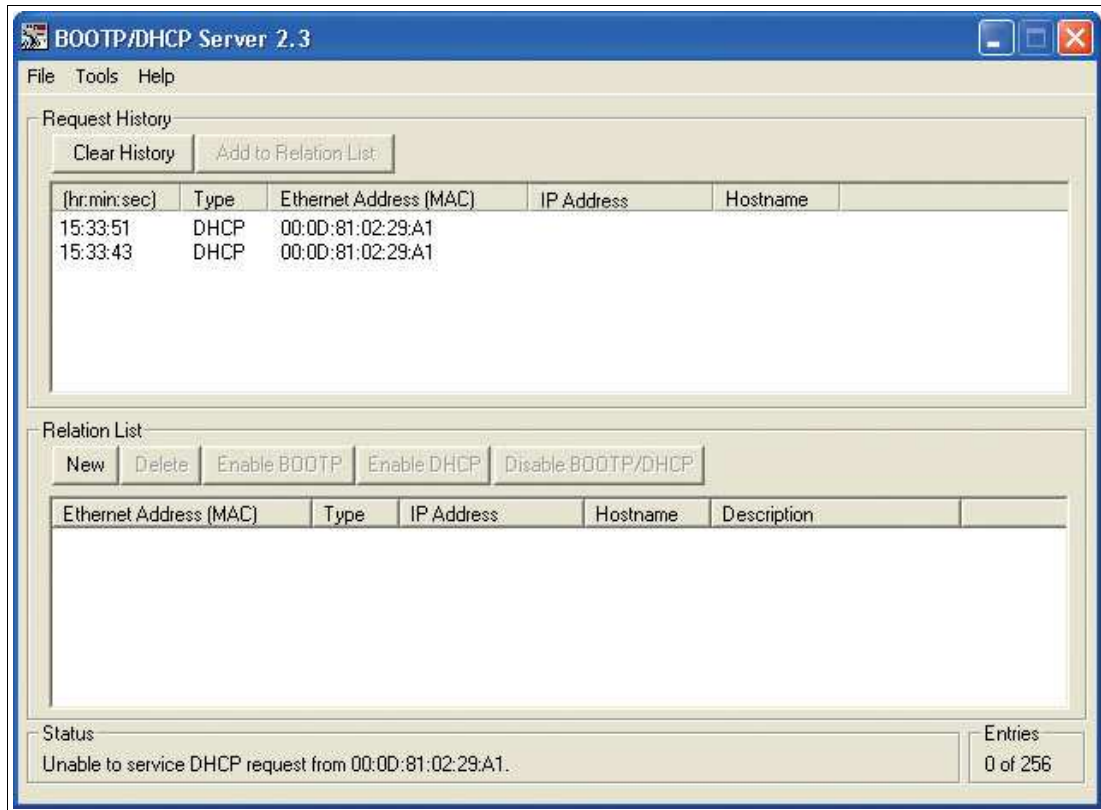

↳ The read head cyclically carries out DHCP requests. The MAC address of the read head is entered in the list in the **Request History** field.

5. Enter the desired IP address in the **New Entry** menu.
  - The software automatically adopts the MAC address of the read head.
  - The "hostname" function is not supported.
  - You may enter text under "Description."

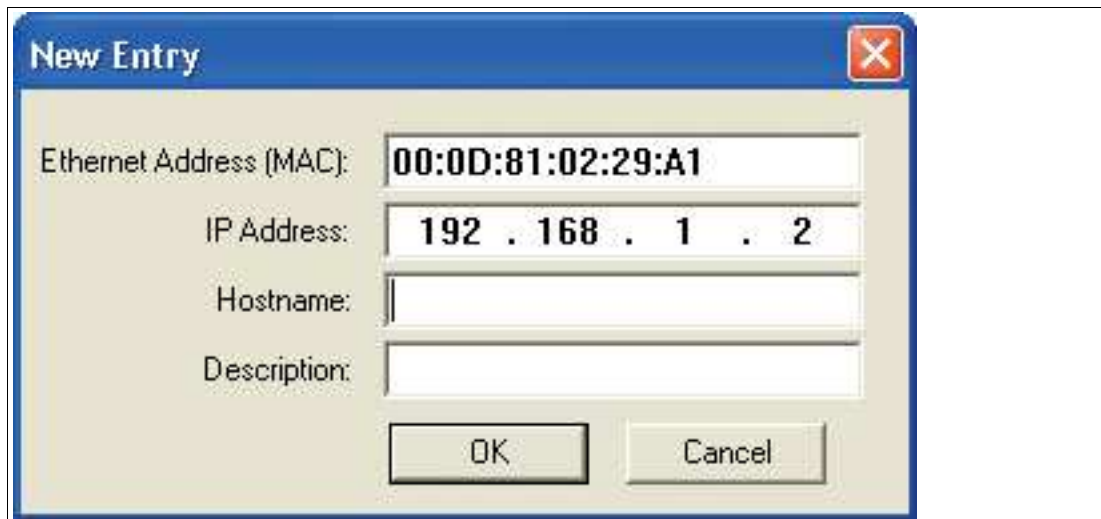

6. Confirm the entries of the address data using **OK**.

↳ The IP address is assigned to the read head on the next DHCP request. The new address data will be displayed in the **Relation List** field.

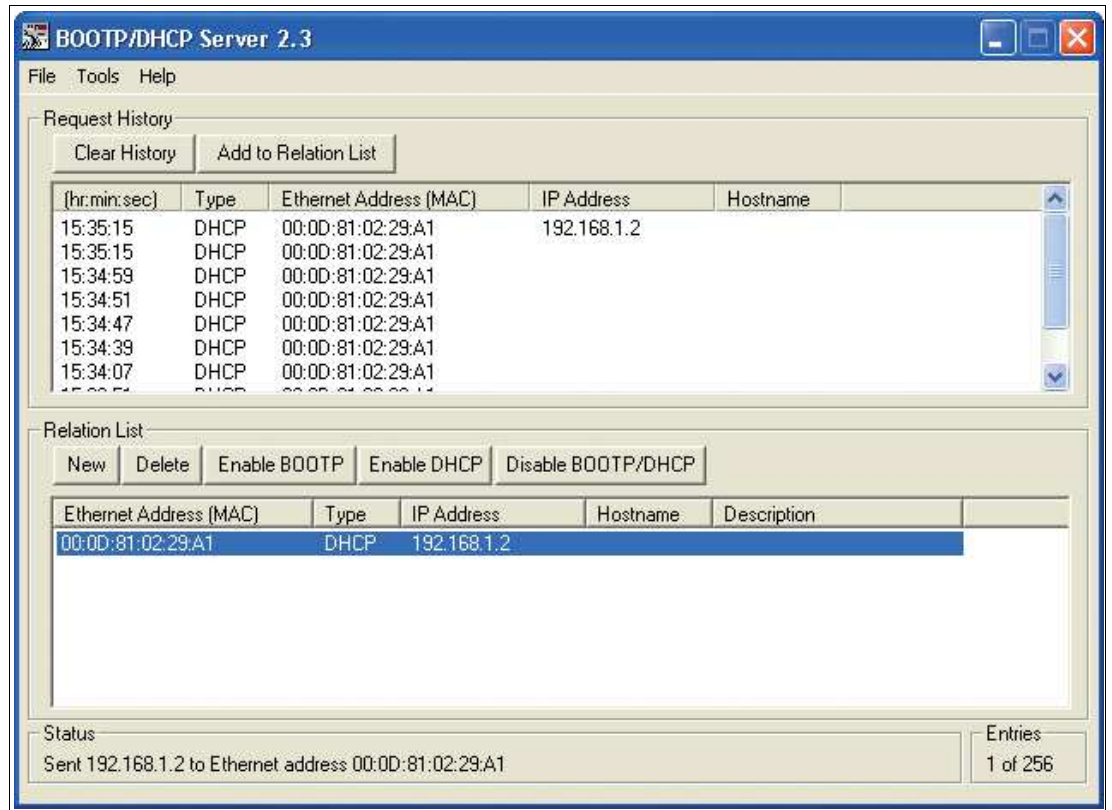

7. Press the **Disable BOOTP/DHCP** key in the **Relation List** field.

↳ In this way, the assigned IP address is saved permanently in the read head.

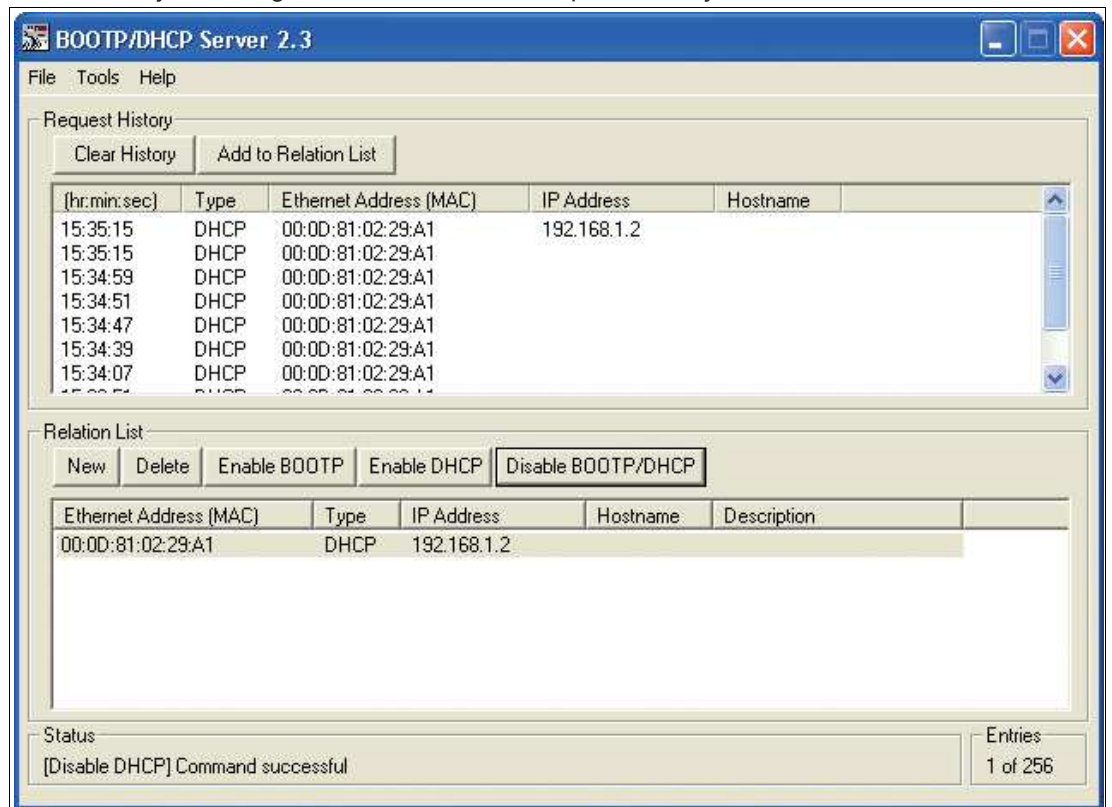

## 7.4 Data Protocols

### EtherNet/IP objects

All the data and functions of the read head are defined via objects in accordance with the EtherNet/IP standards. The read head corresponds to the "Encoder Device Type 0x22" device profile.

The read head supports the following listed standard and product-specific classes.

#### Standard classes

Class ID	Class name
0x01	Identity Object
0x02	Message Router Object
0x04	Assembly Object
0x06	Connection Manager Object
0xF5	TCP/IP Interface Object
0xF6	Ethernet Link Object
0x48	Quality of Service

#### Product-specific class

Class ID	Class name
0x23	Position Sensor Object

The parameters are not directly addressable from the network with the "Set" or "Get" attribute services. Access is via assembly objects (Class Code 0x04)

### Cyclic data communication with assembly objects (Class Code 0x04)

Assemblies are special CIP objects used for cyclic data communication (implicit messaging). These are composed of one or more attributes of various objects. These objects allow you to send or receive data from multiple objects via a connection. The composition of the assemblies in the read head is fixed and cannot be modified by the user.

#### Input assemblies

Instance no.	Description	Size [byte]	Attribute	Attribute ID	Data type
1	Position	4	Position Value Signed	10	DINT
100	Status, position, velocity, faults	7	Position Value Signed	10	DINT
			Status Word	100	USINT
			Velocity Value	101	USINT
			Error Value	102	USINT

## Addresses required for the various connection types

The connection type defines the connection between the control system (originator), in this case the controls, and the target device (target), in this case the read head. The following options are available for data traffic.

### Data from the control system to the target device

Instance no. (dec.)	Size [byte]	Connection type
192	0	Listen only
193	0	Input only

### Data from the target device to the control system

Instance no. (dec.)	Size [byte]	Assemblies
1	4	Position
100	7	Status, position, velocity, faults

## Attributes of the Position Sensor Object (Class ID 0x23)

### Class attributes

ID	Name	Access	Data type	Size [byte]	Description
1	Revision	-	UINT	2	Object inspection

### Standard instance attributes for object 0x23

ID	Attribute	Access	Data type	Size [byte]	Description
10	Position Value Signed	-	DINT	4	Position value signed

The parameters are not directly addressable from the network with the "Set" or "Get" attribute services. You can change the parameters by using assemblies.

### Specific read head attributes

ID	Attribute	Access	Data type	Size [byte]	Description
100	Status Word	-	USINT	1	Status information
101	Velocity	-	USINT	1	Velocity in dm/s
102	Error	-	USINT	1	Fault if content $\neq$ 0

## Basic data structure

1 byte = 8 bit value

Byte 4	Byte 3	Byte 2	Byte 1
Example: XP31 ... XP24 MSB (most significant byte)	Example: XP23 ... XP16	Example: XP15 ... XP08	Example: XP07 ... XP00 LSB (least significant byte)

**Position data X: Position Value Signed (ID 10)**

Size	Type	Content
4 byte consistent	Input data	32-bit X data LSB first LSB = least significant byte At a resolution of 0.8 mm: $L_{\max} = 314.5 \text{ m} = 314,500 \text{ mm}$

**Data for attribute 10**

	Bit 7	Bit 6	Bit 5	Bit 4	Bit 3	Bit 2	Bit 1	Bit 0
Byte 1	XP07	XP06	XP05	XP04	XP03	XP02	XP01	XP00
Byte 2	XP15	XP14	XP13	XP12	XP11	XP10	XP09	XP08
Byte 3	XP23	XP22	XP21	XP20	XP19	XP18	XP17	XP16
Byte 4	XP31	XP30	XP29	XP28	XP27	XP26	XP25	XP24

**Status: Status word (ID 100)**

Size	Type	Content
1 byte	Input data	8 bit status

If the ERR bit is set, there is an error. The error number is transmitted to the "Error value (ID 102)" attribute.

**Data for attribute 100**

Bit no.	Content	Function
	Byte 1 Status	
1	ERR	Error message, error code in ERR00 – ERR07
2	OUT	Read head partially outside the code rail. No valid position available.
3	OUTALL	Read head completely outside the code rail.
4	DB	Diagnostic bit. Read head dirty.
5	SST	Speed status. If the speed status = 1 then the current velocity is unknown. The specified velocity value is invalid.
6	Reserved	-
7	Reserved	-
8	Reserved	-

**Speed: velocity value (ID 101)**

Size	Type	Content
1 byte consistent	Input data	8 bit speed data LSB first Information in dm/s

**Data for attribute 101**

	Bit 7	Bit 6	Bit 5	Bit 4	Bit 3	Bit 2	Bit 1	Bit 0
Byte 1	SP07	SP06	SP05	SP04	SP03	SP02	SP01	SP00

**Faults: error value (ID 102)**

Size	Type	Content
1 byte consistent	Input data	8 bit fault data

**Data for attribute 102**

	Bit 7	Bit 6	Bit 5	Bit 4	Bit 3	Bit 2	Bit 1	Bit 0
Byte 1	ERR7	ERR6	ERR5	ERR4	ERR3	ERR2	ERR1	ERR0

A binary encoded value in attribute 100 means that the corresponding fault is active.

Value	Content	Function
	Byte 1 Status	
0	Error 0	-
1	Error 1	Current position cannot be determined.
2	Error 2	Current position cannot be determined.
3	Error 3	Fault in the RAM working memory.
4	Error 4	Fault in the EPROM memory or in the decoder.
5	Error 5	Fault in the ROM memory.
6	Error 6	-
7	Error 7	-

## 7.5 LED Status Indication

WCS3B-LS5xx\*

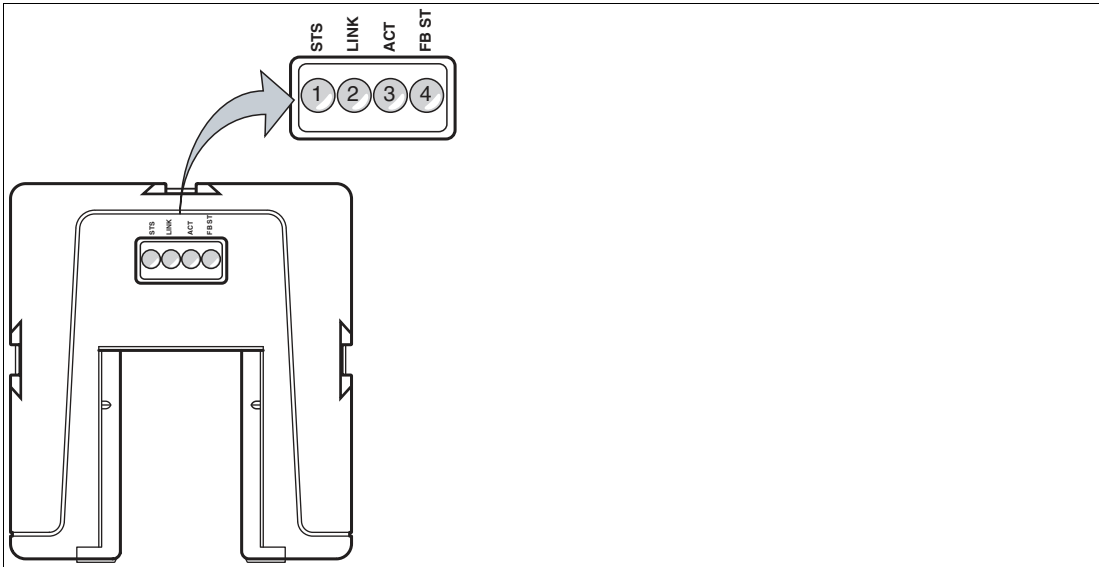

### Description of the LED Indicators

Item	Display	Designation	Color	Display	Meaning
1	STS	Status indicator	green	On	Code rail detected, normal function
			red	On	System error
			red	Flashing	No code rail detected
2	LINK	Ethernet link	green	On	Fieldbus connection exists
3	ACT	Ethernet RX/TX	Yellow	Flashing	Data transfer
4	FB ST	Ethernet communication	red	On	Communication errors



## 8 PROFINET Interface (LS6xx\*)

The WCS3B-LS6xx\* read heads are PROFINET I/O devices that communicate cyclically with the assigned PROFINET I/O controller during operation.

The PROFINET interface of the WCS3B-LS6xx\* read heads supports:

- A transfer rate of 100 Mbit/s
- The real-time category RT
- The range of functions in accordance with **Conformance Class B**
- The identification and maintenance functions (I&M) IM0 – IM4



---

### Note

#### Information on security

From a security perspective, the following precautions must be taken for the product by the responsible application operator:

- Physically secure the device against unauthorized access
  - Ensure that the device is only operated on an isolated network without connection to the corporate network, internet, or cloud services;
    - there the device may only communicate with a higher-level controller, or with a defined, trusted circle of network participants
  - Protect the power supply from unauthorized access:
    - The device has a recovery mode in which the firmware can be changed. The recovery mode is activated by lowering the input voltage to below 9 V!
    - Ensure an input voltage of at least 10 V in normal operation.
-

## 8.1 Electrical Connection



### Caution!

Property damage and system malfunctions due to incorrect pinout

Incorrect assignment of the wire pairs to the respective pins can result in property damage and system malfunctions.

- Note the assignment of the wire pairs to the pins as shown in the respective wiring diagrams.

### Connection diagram for WCS3B read head

The WCS3B-LS6\* read head is connected to PROFINET and the power supply via an 8-pin M12 socket with Y encryption.

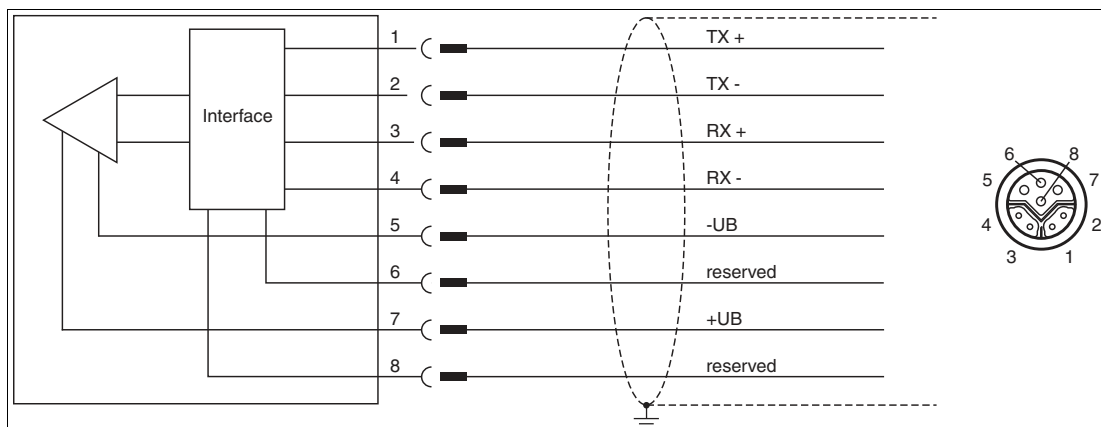

Figure 8.1 WCS3B, PROFINET interface

Pins 6 and 8 are reserved for an internal interface and are connected to ground (-UB).

### Note

A shielded twisted pair cable that meets at least the CAT 5e/CAT 6 specification is used to connect the read head to the control panel. The maximum recommended cable length is 75 m for CAT 5e and 55 m for CAT 6. Longer distances are possible provided that the respective specifications are observed. The connection can be implemented with various cable connections available from Pepperl+Fuchs.

### Y-splitter

There are various options available for the electrical connection. A hybrid cable (see chapter 13.1) with a common data and supply line can be connected directly to the read head. Alternatively, data and supply lines can be routed separately with the Y-splitter.

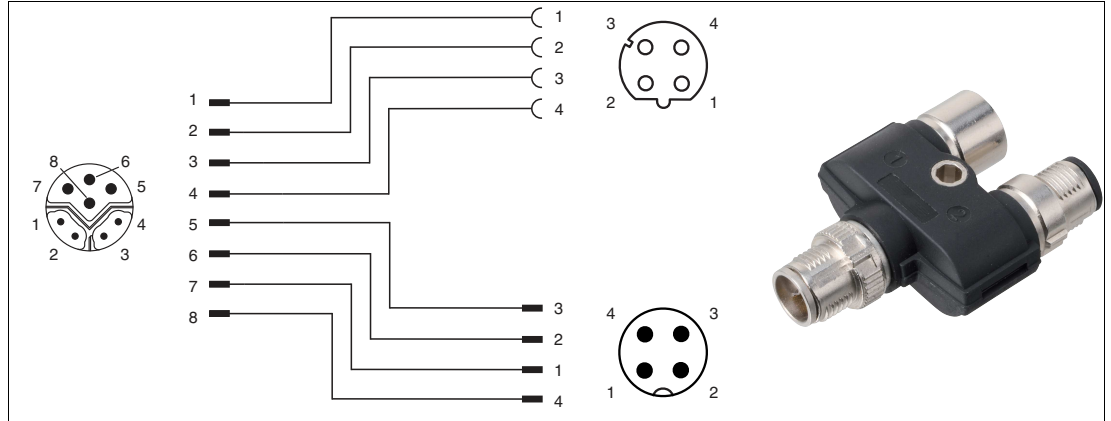

Figure 8.2 V19SY-Y-V1D/V1: Y-splitter, M12 plug Y-encoded to M12 plug A-encoded and M12 socket D-encoded

You can obtain the appropriate connectors and cables from Pepperl+Fuchs, see chapter 13.1.

## 8.2 Hardware Configuration

If you have a read head with the "Display" option, a DIP switch with two switches S1D (2) is installed. This DIP switch allows you to change the display. The 4-way DIP switch (1) in the figure below does not work. The firmware parameters of the read head are set via the corresponding project planning software.

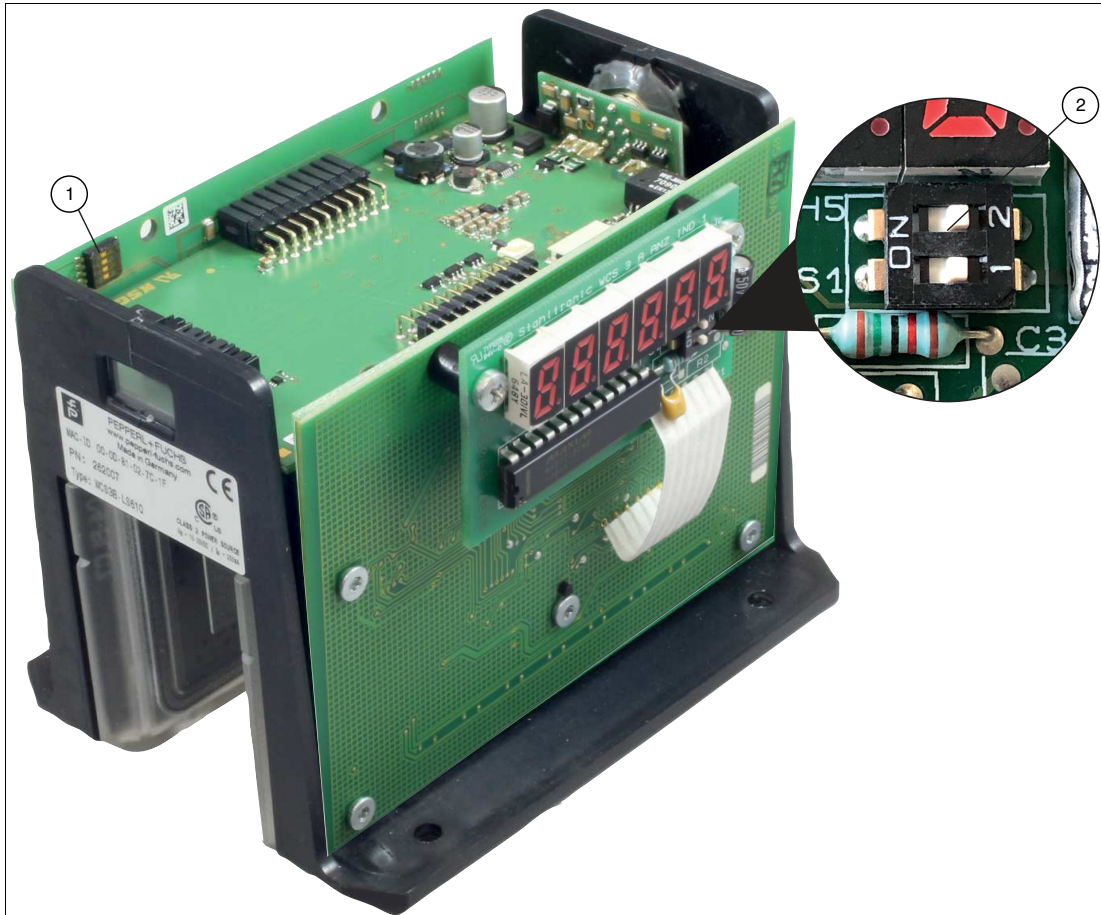

Figure 8.3 Configuration switch positions

1. Configuration switch S1, 4-way (no function)
2. Configuration switch S1D, 2-way (display)

### Adjusting the Display

You can rotate the character position on the display 180° using the S1D DIP switch. This allows you to read the displayed values easily regardless of the installation position of the read head.

WCS3B			
Display position	Configuration switch "S1D"		Comment
	1	2	
0°	OFF	OFF	The displayed value can be read on a code rail mounted upright.
180°	ON	ON	The displayed value can be read on a code rail mounted suspended.

## 8.3 Software Configuration

PROFINET is an open standard for industrial automation based on industrial Ethernet. PROFINET integrates information technology with established standards such as TCP/IP and XML in automation technology.

Within PROFINET, PROFINET IO is the communication concept for the construction of decentralized applications. This means that read heads are integrated through PROFINET IO. The familiar IO view of PROFIBUS DP is used where the usable data of the read heads is transferred to the process image of the control panel in cycles. PROFINET IO is a device model consisting of slots and channels, which is based on the main features of PROFIBUS DP. The properties of the read heads are written in a Generic Station Description Markup Language (GSDML) based on XML. PROFINET IO is engineered in such a way that the read heads are assigned to a control panel in project planning.

PROFINET IO distinguishes between the following three device types:

- IO controller: Controller that executes the automation program.
- IO device: Decentrally assigned field device that is assigned to an IO controller.
- IO supervisor: Programming unit/PC with commissioning and diagnostic functions.

The read head functions as a PROFINET I/O device that communicates cyclically with the assigned PROFINET I/O controller during operation.

### Project planning using device description

The read head is integrated into the project planning tool by way of a device description. The field device properties are described in the GSDML file. The GSDML file contains the data of the field device that you need to operate the device in a PROFINET network. You import the GSDML file into a project planning tool that you use to configure the read head settings. Once project planning is complete, the control panel receives the project planning data and configuration data.

### Downloading the GSDML file

You can find the relevant GSDML file in the **Software** section of the product detail page for the device.

To access the product detail page for the device, go to <http://www.pepperl-fuchs.com> and type e.g., the product description or the item number into the search function.

## PROFINET address and identifying a device

Every read head has a unique device identification. This device identification consists of the following:

- A unique **MAC address**. This MAC address is printed on the back of the device.
- A **device name**. The default device name is `wcs3b-1s610`.
- An **IP address**. The default IP address is `192.168.2.2`.



### Identification & maintenance—calling up and editing data

Identification & maintenance data (I&M data) is information stored in a device. I&M data uniquely identifies a device within a plant. The identification data (I data) includes information about the device, for example the item number and device name. Identification data cannot be changed.

Maintenance data (M data) includes information about the device within the plant, for example the installation location and installation date. Maintenance data is initially stored in the device during installation. Maintenance data can be changed.

The Step7 software from Siemens can be used to display and change the I&M data.

1. To do so, open the hardware configuration **HW Config** and call up the "Target system" menu.
2. Open one of the following functions:
  - "Download module identification"
  - "Download module identification in PG"

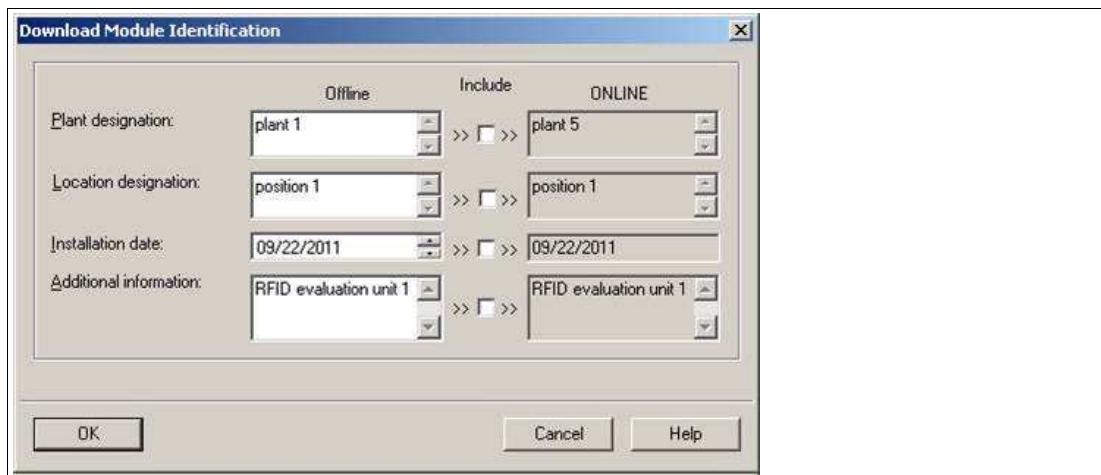

Figure 8.4

3. Depending on the requirement, read or edit the following I&M data:
  - I&M data 1: plant designation, location designation
  - I&M data 2: installation date
  - I&M data 3: additional information

## 8.4 Data Protocols

The WCS3B-LS6xx\* read heads are PROFINET I/O devices that communicate cyclically with the assigned PROFINET I/O controller during operation.

The PROFINET interface of the WCS3B-LS6xx\* read heads supports:

- A transfer rate of 100 Mbit/s
- The real-time category RT
- The range of functions in accordance with **Conformance Class B**
- The identification and maintenance functions (I&M) IM0 – IM4

### Modules with response telegram

The following modules enable read head data to be retrieved using PROFINET.

#### Position Data X Module

Size	Type	Content
2 words, consistent	Input data	32-bit X data MSB first MSB = <b>most significant byte</b> Resolution: 0.8 mm, binary coded $L_{max} = 314.5 \text{ m} = 314500 \text{ mm}$

#### Response

Bit no.	Content	
	Word 1 X data	Word 2 X data
1	XP16	XP00
2	XP17	XP01
3	XP18	XP02
4	0	XP03
5	0	XP04
6	0	XP05
7	0	XP06
8	0	XP07
9	0	XP08
10	0	XP09
11	0	XP10
12	0	XP11
13	0	XP12
14	0	XP13
15	0	XP14
16	0	XP15

## Speed data module

Size	Type	Content
1 byte	Input data	8 bit speed data Resolution: 0.1 m/s, binary coded Speed of 0 ... 12.5 m/s <b>Example:</b> Speed = 4.7 m/s --> speed output = 47 with resolution 0.1 m/s 126 for speed > 12.5 m/s 127 for unknown speed

### Response

Bit no.	Content
	Word 1 Speed
1	SP00
2	SP01
3	SP02
4	SP03
5	SP04
6	SP05
7	SP06
8	SP07

## Error message module

Size	Type	Content
1 byte	Input data	8 bit numerical value ERR message from 0 ... 7 <b>Example:</b> ERR message = 00000001 = Error 1 Error 1 corresponds to "Current position cannot be determined"

### ERR messages

Error	Content	Function
	Byte 1 Status	
0	ERR00	-
1	ERR01	Current position cannot be determined
2	ERR02	Current position cannot be determined
3	ERR03	Fault in the working memory (RAM)
4	ERR04	Fault in the EPROM memory or in the decoder
5	ERR05	Fault in the ROM memory
6	ERR06	-
7	ERR07	-



### Status module

Size	Type	Content
1 byte	Input data	8 bit status

### Response

Bit no.	Content	Function
	Byte 1 Status	
1	ERR	Error message, see error codes ERR00 – ERR07
2	OUT	Read head partially outside the code rail. No valid position available.
3	OUTALL	Read head completely outside the code rail.
4	DB	Diagnostic bit. Read head dirty.
5	SST	Speed status
6	Reserved	-
7	Reserved	-
8	Reserved	-

## 8.5 LED Status Indication

WCS3B-LS6xx\*

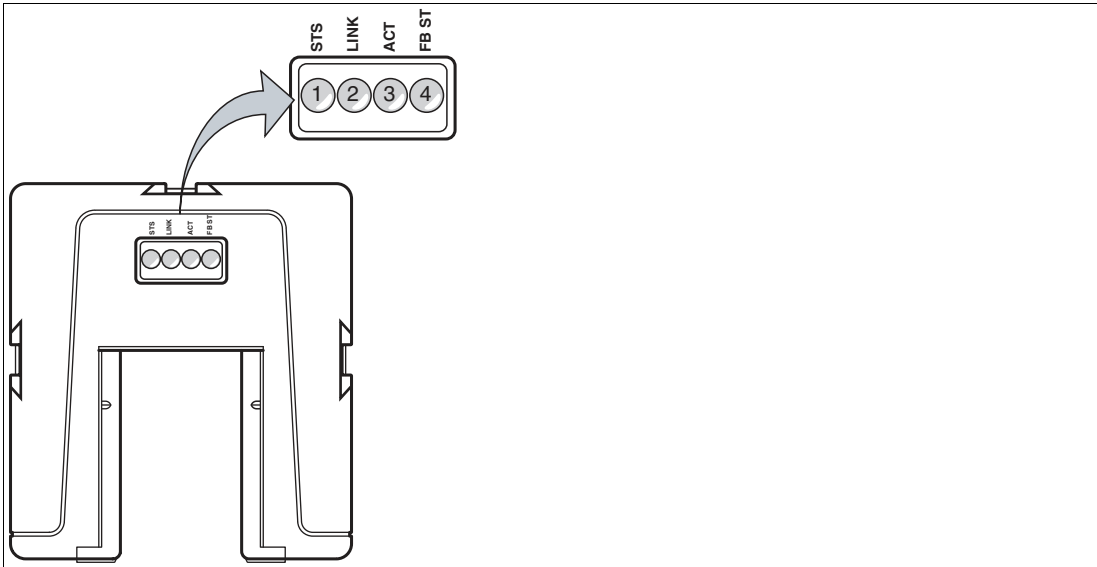

### Description of the LED Indicators

Item	Display	Designation	Color	Display	Meaning
1	STS	Status indicator	green	On	Code rail detected, normal function
			red	On	System error
			red	Flashing	No code rail detected
2	LINK	Ethernet link	green	On	Fieldbus connection exists
3	ACT	Ethernet RX/TX	yellow	Flashing	Data transfer
4	FB ST	Ethernet communication	red	On	Communication errors

## 9 EtherCAT® Interface (LS7xx\*)

The WCS3B-LS7xx\* read heads provide an EtherCAT®<sup>1</sup>The device communicates cyclically with the assigned EtherCAT® controller during operation.

The EtherCAT® interface of the WCS3B-LS6xx\* read heads supports:

- A transfer rate of 100 Mbit/s
- Data transfer via "CANopen over EtherCAT®" (CoE)
- Firmware update via "File access over EtherCAT®" (FoE)
- Selectable modules with data structure
  - Standard
  - Backward-compatible with older WCS gateways WCS-ECG110
- End node in the line structure. Combined Y-plug with data port and accessory cable, T-adaptor for separation on two standardized M12-connections 4-pin



### Note

#### Information on security

From a security perspective, the following precautions must be taken for the product by the responsible application operator:

- Physically secure the device against unauthorized access
- Ensure that the device is only operated on an isolated network without connection to the corporate network, internet, or cloud services;
  - there, the device may only communicate with a higher-level controller, or with a defined, trusted circle of network participants
- Protect the power supply from unauthorized access:
  - The device has a recovery mode in which the firmware can be changed. The recovery mode is activated by lowering the input voltage to below 9 V!
  - Ensure an input voltage of at least 10 V in normal operation
- Ensure that only authorized users have access to the FoE feature on the network
  - The device supports file access over EtherCAT® (FoE). Firmware changes are always possible with the FoE function!

The EtherCAT® controller can be used to query the firmware version during initialization to detect firmware changes.

1. EtherCAT® is a registered trademark and patented technology, licensed by Beckhoff Automation GmbH, Germany.

## 9.1 Power Source



### Caution!

Property damage and system malfunctions due to incorrect pinout

Incorrect assignment of the wire pairs to the respective pins can result in property damage and system malfunctions.

- Note the assignment of the wire pairs to the pins as shown in the respective wiring diagrams.

### Connection diagram for WCS3B read head

The WCS3B-LS7\* read head is connected to EtherCAT and the voltage supply via an 8-pin M12 socket with Y encryption.

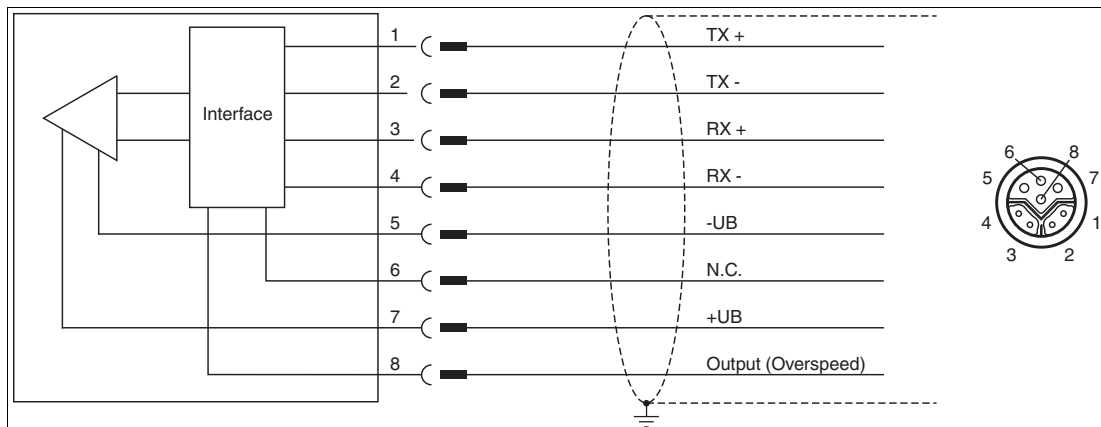

Figure 9.1 EtherCAT Interface



### Note

A shielded twisted-pair cable that meets at least the CAT 5e/CAT 6 specification is used to connect the read head to the control panel. The maximum recommended cable length is 75 m for CAT 5e and 55 m for CAT 6. Longer distances are possible provided that the respective specifications are observed. The connection can be implemented with various cable connections available from Pepperl+Fuchs.

### Y-splitter

There are various options available for the electrical connection. A hybrid cable (see chapter 13.1) with a common data and supply line can be connected directly to the read head. Alternatively, data and supply lines can be routed separately with the Y-splitter.

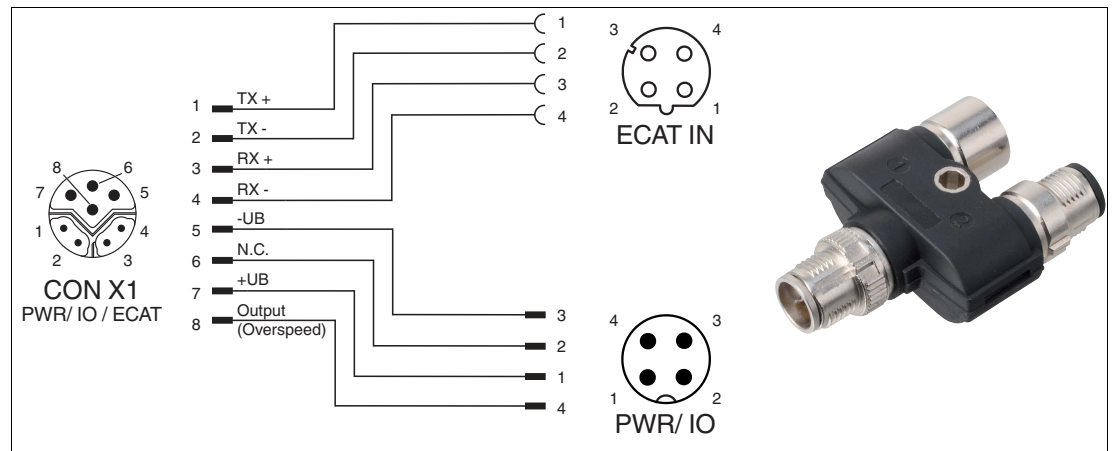

Figure 9.2 V19SY-Y-V1D/V1: Y-splitter, M12 plug Y-coded to M12 plug A-coded and M12 socket D-coded

You can obtain the appropriate connectors and cables from Pepperl+Fuchs, see chapter 13.1.

## 9.2 Hardware Configuration

The WCS3B read head with velocity output features an additional 24 VDC output, which transmits a signal in the event that a limit speed is exceeded. The limit speed can be configured on the 4-way DIP switch in the read head. The limit speed is set to 0.7 m/s on delivery.

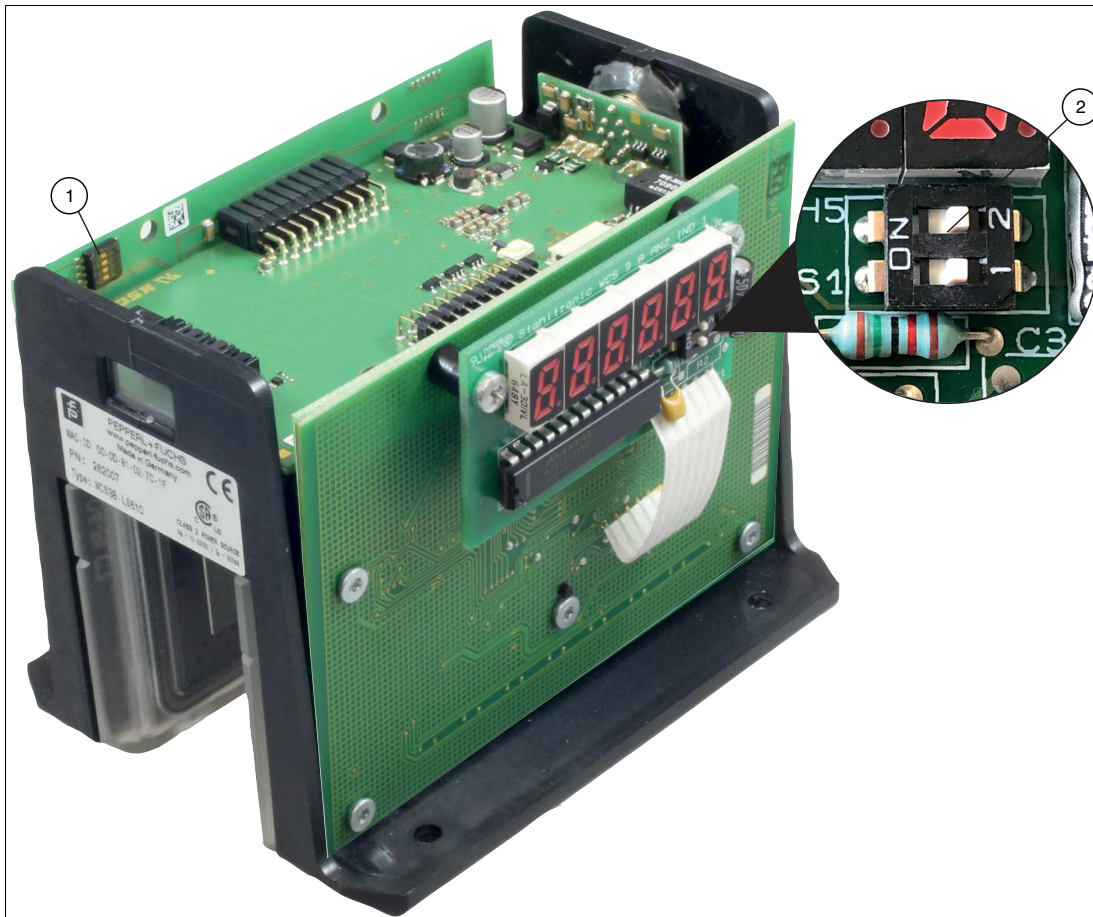

Figure 9.3 Configuration switch positions

1. Configuration switch S1, 4-way (limit speed)
2. Configuration switch S1D, 2-way (display)

### Set the Limit Speed

Limit speed $v_{\text{limit}}$	S1			
	1	2	3	4
0.7 m/s	X	X	OFF	OFF
2.0 m/s	X	X	OFF	ON
3.0 m/s	X	X	ON	OFF
4.0 m/s	X	X	ON	ON

The limit speed is output digitally via pin 8 of the 8-pin M12 socket with Y-coding:

$U_v$  (pin 8) = operating voltage  $U_B \rightarrow v_{\text{current}} < v_{\text{limit}}$

$U_v$  (pin 8) = floating (high impedance)  $\rightarrow v_{\text{current}} \geq v_{\text{limit}}$



**Note**

**LED limit speed status display**

**Yellow LED off:** Limit speed exceeded



**Note**

The set limit speed is not noted on the nameplate of the read head.

**Adjusting the Display**

You can rotate the character position on the display 180° using the S1D DIP switch. This allows you to read the displayed values easily regardless of the mounting position of the read head.

WCS3B			
Display position	Configuration switch "S1D"		Comment
	1	2	
0°	OFF	OFF	The displayed value can be read on a code rail mounted upright.
180°	ON	ON	The displayed value can be read on a code rail mounted suspended.

## 9.3 EtherCAT® Communication Methods

For the CANopen over EtherCAT® (CoE) protocol supported by the read head, most objects are supported for the communication layer according to the CIA's DS301 CANopen standard by EtherCAT®. These are mostly objects for setting up communication between the control unit and the bus node.

The EtherCAT® protocol uses two different types of transfer to transfer the device and user protocols, such as the CoE protocol. These two transfer types are the mailbox telegram protocol for transmitting acyclic data and the process data telegram protocol for transmitting cyclic data.

For the CoE protocol, these two transfer types are used for the different types of CANopen transfer. They are used as follows:

- **Mailbox Telegram Protocol:**  
This transfer type is used to transfer the service data objects (SDO) defined under CANopen. Service data objects control the parameter data exchange, e.g., the acyclic execution of the preset function. They are transmitted in EtherCAT® in SDO frames.
- **Process Data Telegram Protocol:**  
This transfer type is used to transfer the process data objects (PDO) defined under CANopen. Process data objects manage the process data exchange, e.g., the cyclic transfer of the position value. They are transmitted in EtherCAT® in PDO frames.



## 9.4 Software Configuration

The following pages provide an example of how to configure a read head using the "TwinCAT®" project planning and development environment from Beckhoff Automation GmbH.

### Configuration with TwinCAT® 3

There are two possibilities for the configuration of the EtherCAT® readhead:

- **Offline configuration**, if configuration is to take place before the plant creation, e.g., on a laptop as a programming system
- **Online configuration** via a scan of the existing network (preferred), if the control panel is already connected to the EtherCAT® system and all components of the EtherCAT® network are ready for operation.

#### Sample online configuration

The following describes the online configuration.

Here, all available nodes are automatically integrated into the EtherCAT® network by the master.

### Device Description File—ESI File

With EtherCAT®, all process data and the parameters are described in objects. The compilation of all the process data and parameters (the object directory) is stored in an EtherCAT® description file (ESI file, EtherCAT® slave information file).

This ESI file contains all objects with index, subindex, name, data type, data access, and the value range with minima, maxima, and default value. The ESI file describes the complete functionality of the device. It is possible to adapt the communication between the device and the control via these objects.

#### Downloading and Installing the ESI File

You can find the relevant ESI file in the **Commissioning** section of the product detail page for the device. To access the product detail page for the device, go to <http://www.pepperl-fuchs.com> and use the search function to search by the product description or the item number.

Install the ESI file using your controller manufacturer's configuration software. For TwinCAT®, the ESI file must normally be copied into the installation folder. After installation, the object data of the ESI file is available in the hardware catalog.



## Creating a New Project in TwinCAT® 3

To connect your read head to the controller, you must create a new project in TwinCAT® 3.

1. Start TwinCAT® 3 on your PC.
2. On the start page, select the option "New TwinCAT Project..."
3. Select "TwinCAT XAE Project (XML format)," enter a project name, and confirm your selection with "OK."

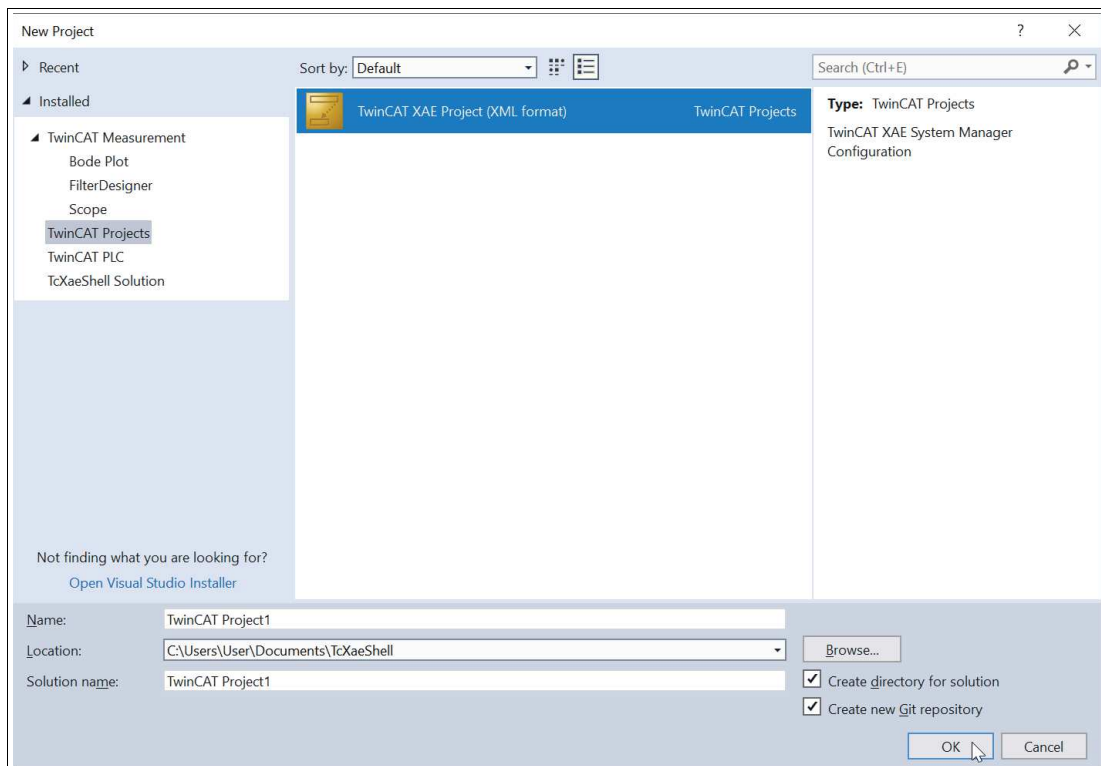

Figure 9.4 Creating a New Project



### Note

It is generally possible to use the TwinCAT locally or remotely. If the TwinCAT system including user interface is installed on the relevant controller (locally), TwinCAT can be used locally. In this example, TwinCAT is used locally.



### Integrate the controller in TwinCAT® 3

1. Install the ESI file of the module family in TwinCat®. In TwinCAT® 3, the ESI file is normally inserted in the installation folder `C:\TwinCAT\3.1\Config\Io\EtherCAT®`.  
↳ After you restart TwinCAT®, the modules will be available in the hardware catalog.
2. Start TwinCat and open a new project.



#### Note

After creating the project, you must first take the following steps to establish communication with the controller.

3. In the left-hand working area of "Solution Explorer", switch to the option "I/O."
4. Right-click on "Devices" and select the "Add New Item..." option.

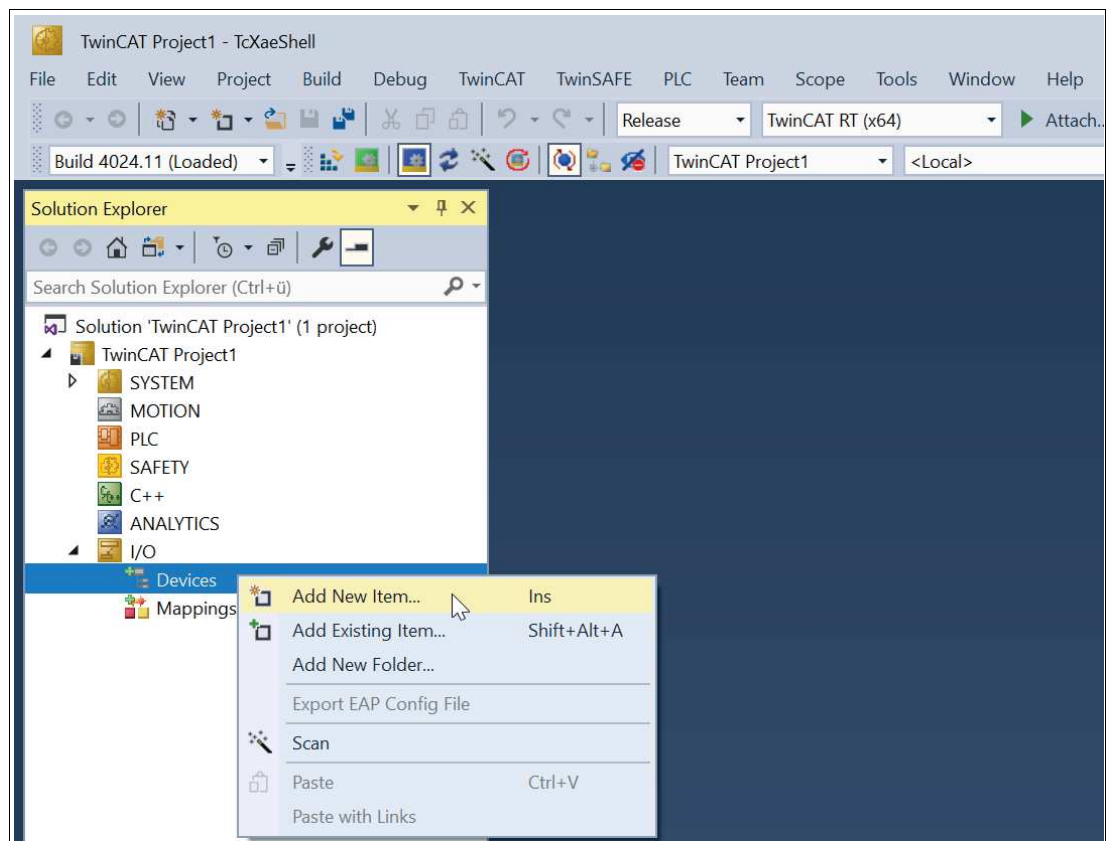

Figure 9.5

↳ The "Insert Device" selection window opens.

5. Select "EtherCAT® Master" and confirm with "OK."

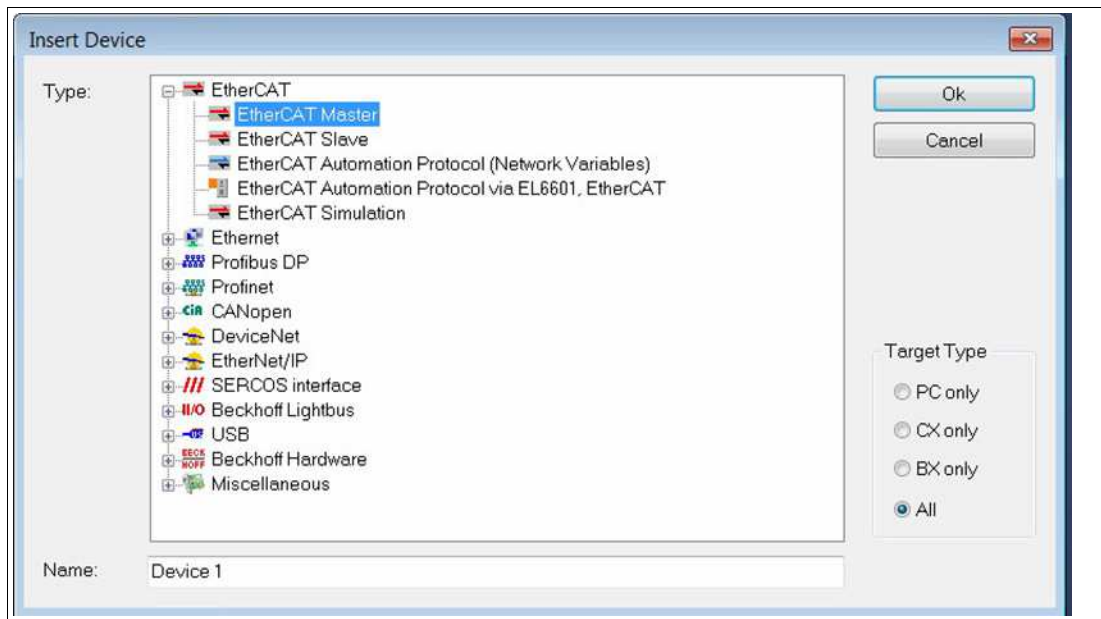

Figure 9.6

↳ The EtherCAT® controller is created in the "Solution Explorer" project tree with the designation "Device 1 (EtherCAT®)."

6. In the "Solution Explorer" project tree, select the controller with the designation "Device 1 (EtherCAT®)" with a left mouse click.

↳ The properties page opens on the right side of the window.

7. Click the "Adapter" tab, followed by "Search..." to select the port for your controller.

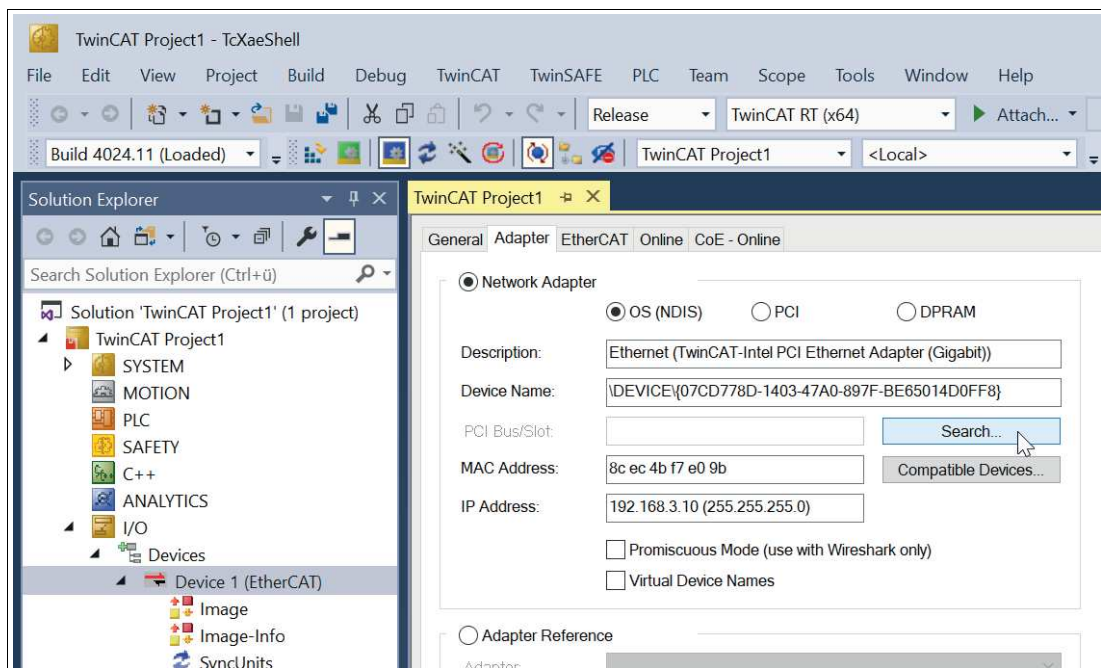

Figure 9.7

8. In the "Device Found At" dialog, select the port for your controller; in this example, the "Ethernet (TwinCAT-Intel PCI Ethernet adapter (Gigabit))" is used.

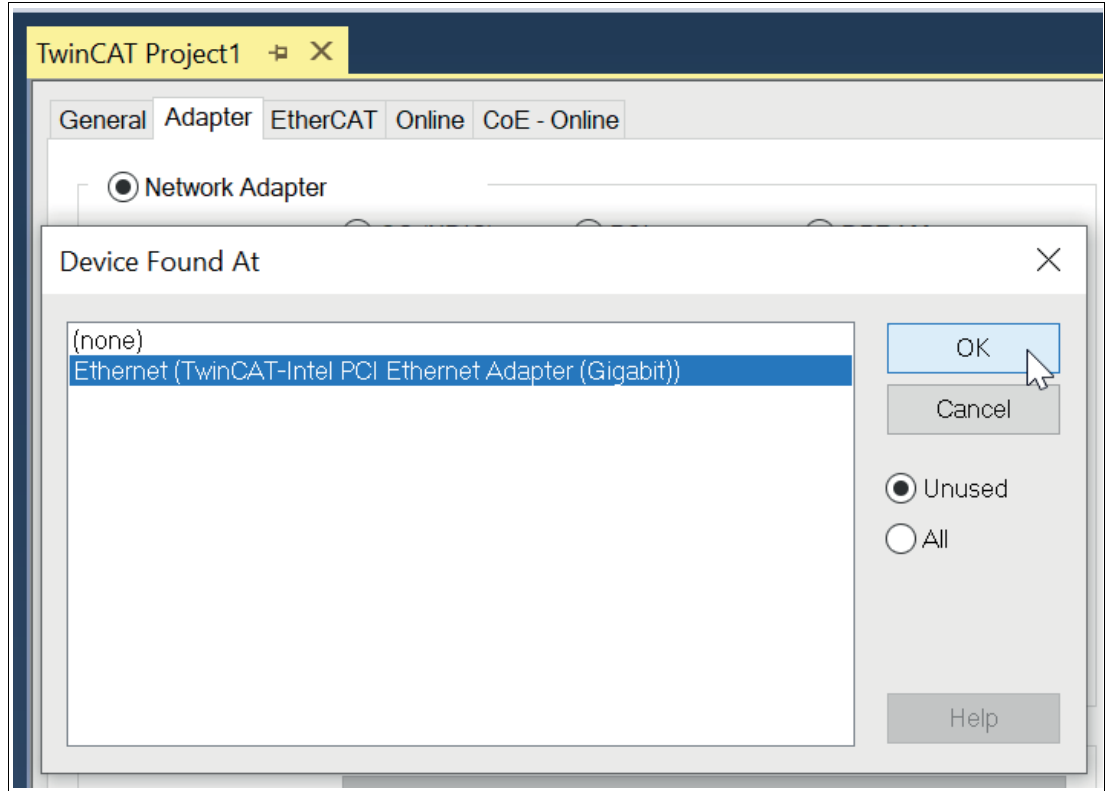

Figure 9.8

9. Click on the "OK" button to confirm the selection.



## Adding the Read Head to the Project

1. To add the read head to the controller, right-click on "Device 1 (EtherCAT®)" in the project tree. Activate the "Scan" function with the right mouse button.

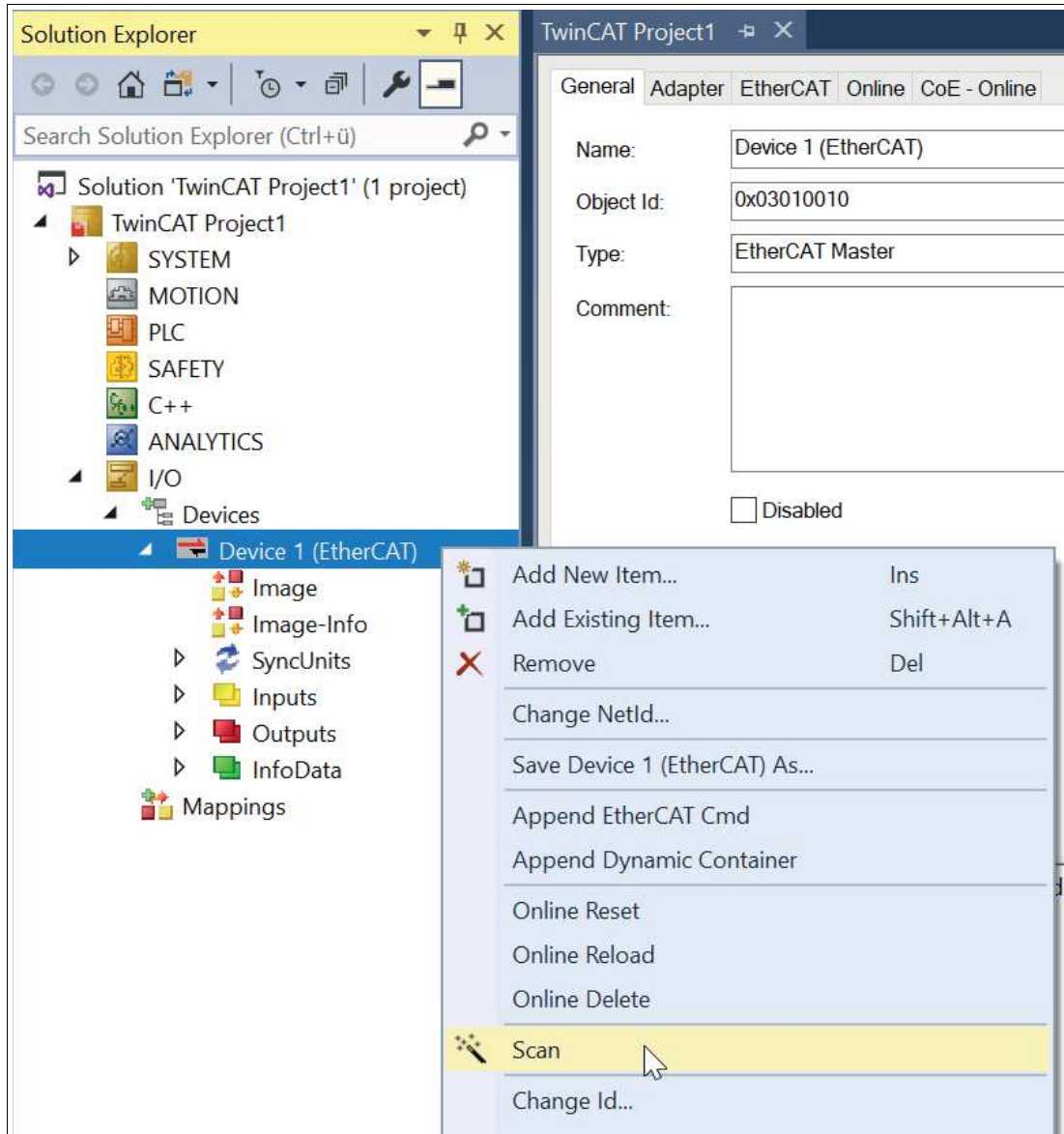

Figure 9.9

- ↳ All EtherCAT® nodes are read in and automatically added to the I/O configuration. The WCS3B-LS710x read head appears in the project tree below the EtherCAT® controller as Box 1 (WCS3B-LS710x).

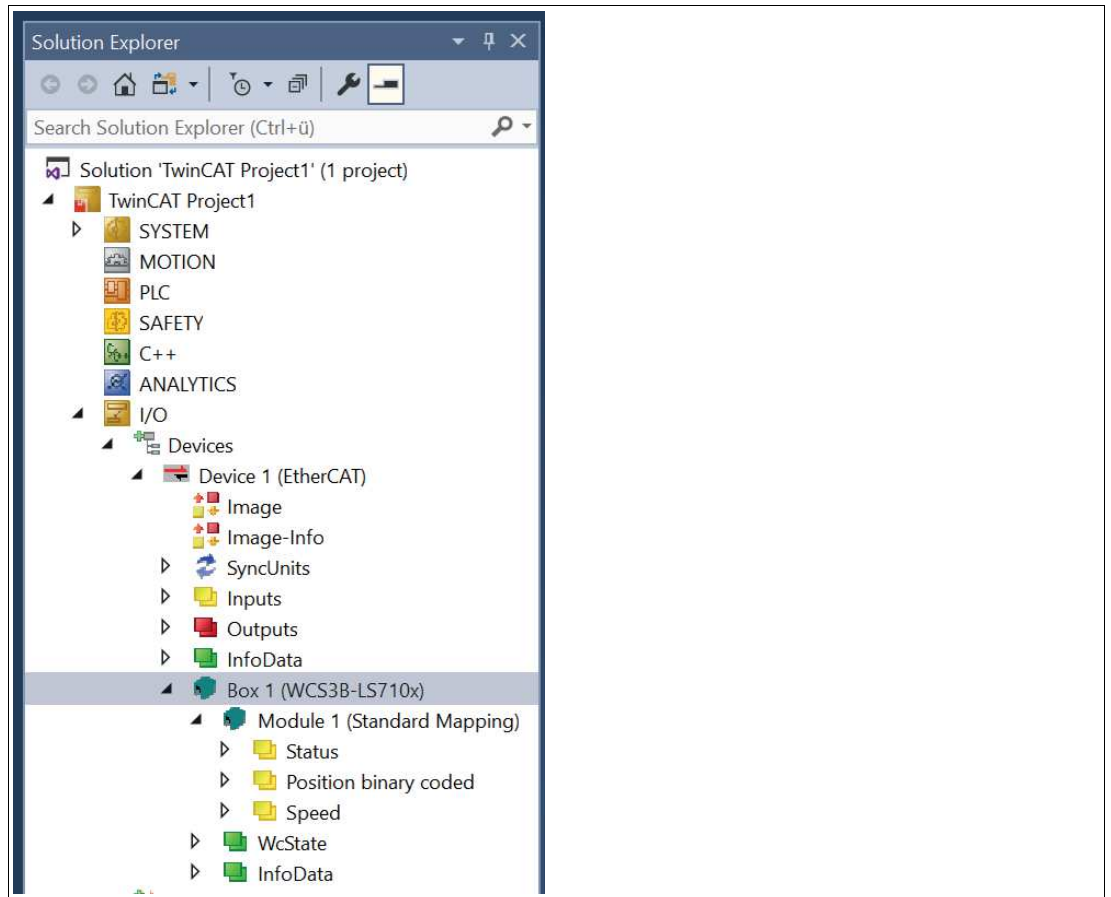

Figure 9.10

2. Click on the entry "Box 1 (WCS3B-LS710x)" using the left mouse button.  
↳ The menu "TwinCAT Project 1" is displayed.
3. To configure the process data, go to the "Process Data" tab.

**Sync Manager:**

SM	Size	Type	Flags
0	128	MbxOut	
1	128	MbxIn	
2	0	Outputs	
3	6	Inputs	

**PDO List:**

Index	Size	Name	Flags	SM	SU
0x1A10	1.0	Status	MF	3	0
0x1A11	4.0	Position binary coded	F	3	0
0x1A12	4.0	Position gray code	F	3	0
0x1A13	1.0	Speed	F	3	0
0x1A14	1.0	Error Code	F	3	0

**PDO Assignment (0x1C13):**

0x1A10  
 0x1A11  
 0x1A12  
 0x1A13  
 0x1A14

**PDO Content (0x1A10):**

Index	Size	Offs	Name	Type	Default (hex)
0x6010:01	0.1	0.0	error	BIT	
0x6010:02	0.1	0.1	out	BIT	
0x6010:03	0.1	0.2	outAll	BIT	
0x6010:04	0.1	0.3	db	BIT	
0x6010:05	0.1	0.4	set	BIT	

**Download:**

PDO Assignment  
 PDO Configuration

**Predefined PDO Assignment: (none)**

**Load PDO info from device**

**Sync Unit Assignment...**

Name	Online	Type	Size	>Addr...	In/Out	User ID	Linked to
error	0	BIT	0.1	39.0	Input	0	
out	0	BIT	0.1	39.1	Input	0	
outAll	0	BIT	0.1	39.2	Input	0	
db	0	BIT	0.1	39.3	Input	0	
sst	0	BIT	0.1	39.4	Input	0	
Position (binary)	278082	UDINT	4.0	40.0	Input	0	
Speed	0	USINT	1.0	44.0	Input	0	
WcState	0	BIT	0.1	1522.1	Input	0	
InputToggle	0	BIT	0.1	1524.1	Input	0	
State	8	UINT	2.0	1548.0	Input	0	
.AdsAddr	192.168.240.99.2.1:...	AMSADDR	8.0	1550.0	Input	0	

- In the "Sync Manager" section, click on the "Inputs" option and select your input PDOs in the "PDO Assignment" area.
- For example, clear the "0x1A12" check box if position data in gray code should not be transferred to the EtherCAT® controller.
- To set the TwinCAT system manager to "Config Mode", restart TwinCAT. To do this, click the "Restart TwinCAT (Config Mode)" button (1). Click "OK" to confirm the dialog (2).



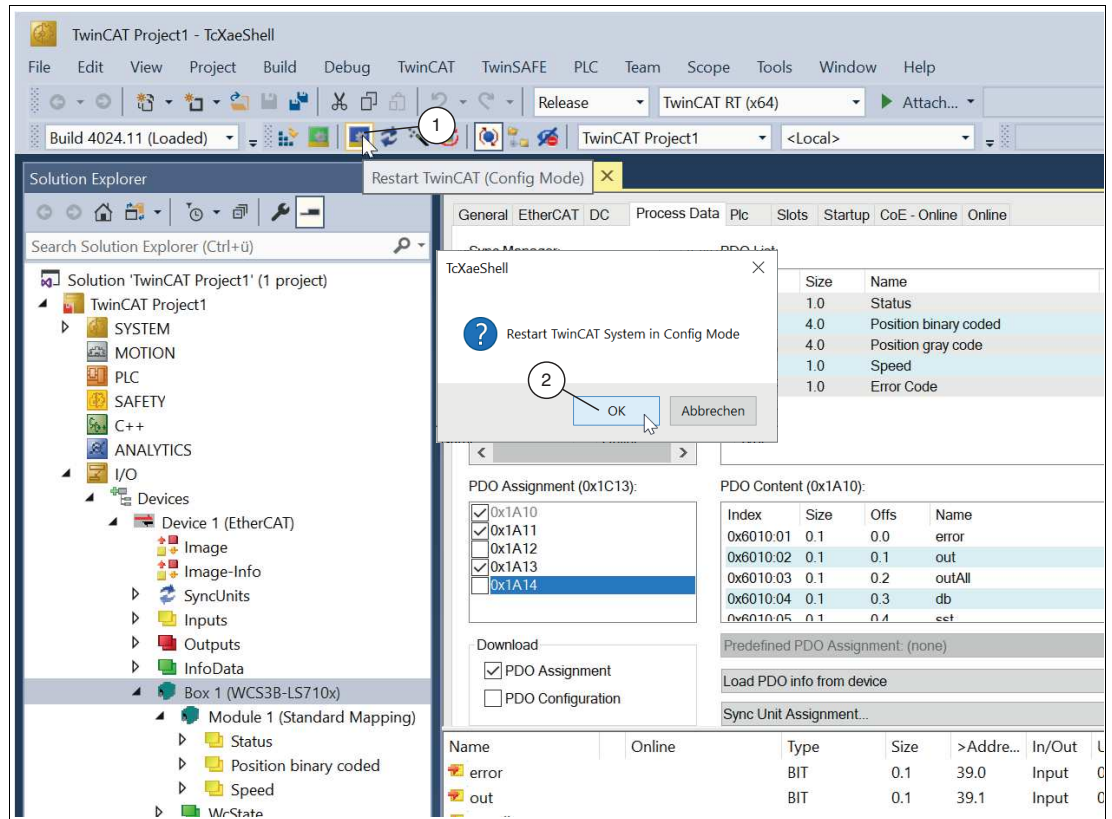

Figure 9.11

7. Confirm the message "Load I/O Devices" with "OK."  
 ↳ The message "Activate Free Run" appears.
8. Confirm the dialog with "Yes" to allow the processing of input data within the "Config Mode."

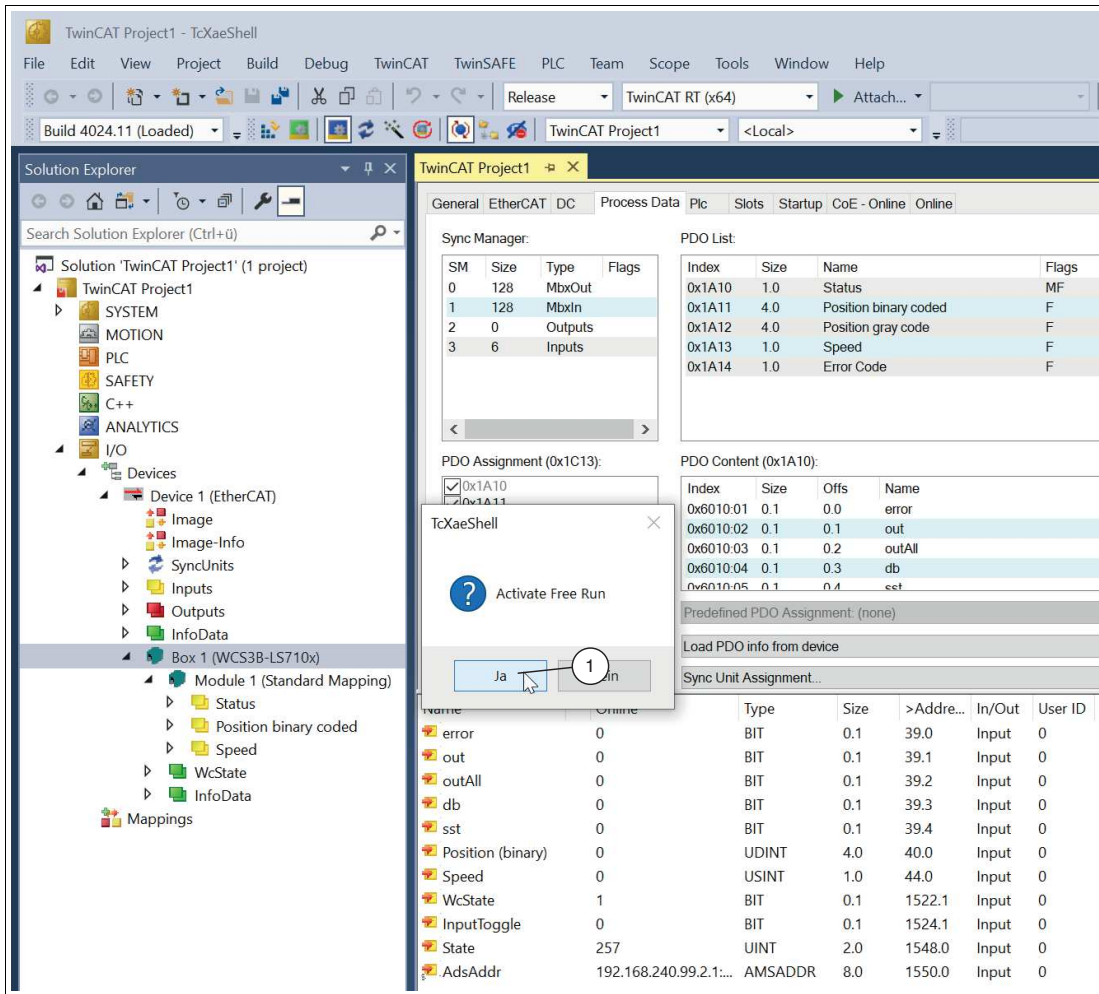

Figure 9.12

## 9.5 Data Protocols

For the CANopen over EtherCAT® (CoE) protocol supported by the read head, most objects are supported for the communication according to the CIA's DS301 CANopen standard by EtherCAT®.

The EtherCAT® protocol uses two different types of transfer to transmit the device and user protocols, such as the CoE protocol. These two transfer types are the mailbox telegram protocol for transmitting acyclic data and the process data telegram protocol for transmitting cyclic data.

For the CoE protocol, these two transfer types are used for the different types of CANopen transfer. They are used as follows:

- **Mailbox Telegram Protocol:**  
This transfer type is used to transfer the service data objects (SDO) defined under CANopen. Service data objects control the parameter data exchange, e.g., the acyclic execution of the preset function. They are transmitted in EtherCAT® in SDO frames.
- **Process Data Telegram Protocol:**  
This transfer type is used to transfer the process data objects (PDO) defined under CANopen. Process data objects manage the process data exchange, e.g., the cyclic transfer of the position value. They are transmitted in EtherCAT® in PDO frames.

In the case of CANopen over EtherCAT® (CoE), all parameters are located in what is known as the object directory. They can be changed or read there using the SDO (service data object) telegram, specifying their index and subindex.

The following table shows an overview of the supported indexes in the communication profile area:

### Object directory

Index (hex) box	Object name	Link
Default objects		
0x1000	Device type	See "Object 0x1000—Device Type" on page 84
0x1008	Device name	See "Object 0x1008: Manufacturer Device Name" on page 84
0x1009	Hardware version	See "Object 0x1009: Hardware version" on page 84
0x100A	Software version	See "Object 0x100A: Software Version" on page 84
0x1018	Identify object	See "Object 1018: Identify Object" on page 84
0x1C00	Sync manager Communication type (sync manager type)	See "Object 1C00: Sync Manager Communication Type" on page 85
0x1C12	RxPDO assign	See "Object 1C12: RxPDO Assignment" on page 85
0x1C13	TxPDO assign	See "Object 1C13: TxPDO assignment" on page 86
Profile-specific objects		
0xF000	Modular device profile	See "Object F000: Modular Device Profile" on page 86
Manufacturer-specific objects		
0x3000	Pepperl+Fuchs serial number	See "Object 3000: Pepperl+Fuchs Serial Number" on page 86

For the tables below, the following applies:

ro (= read **only**) means read-only access

rw (= read **write**) means reading and writing permitted

### Object 0x1000—Device Type

This object specifies which device type it relates to.

Index	Subindex	Object name	Data type	Default	Access
0x1000	0x00	Device type	unsigned32	0x1389(5001)	ro

### Object 0x1008: Manufacturer Device Name

This object specifies the manufacturer-specific device name.

Index	Subindex	Object name	Data type	Default	Access
0x1008	0x00	Manufacturer Device Name	string	-	ro

### Object 0x1009: Hardware version

This object specifies the status of the hardware version of the read head.

Index	Subindex	Object name	Data type	Default	Access
0x1009	0x00	Hardware version	string	-	ro

### Object 0x100A: Software Version

This object specifies the status of the software version.

Index	Subindex	Object name	Data type	Default	Access
0x100A	0x00	Software version	string	-	ro

### Object 1018: Identify Object

This object provides general information about the device. Keep these values available for service requests.

Index	Subindex	Object name	Data type	Default	Access
0x1018	0x00	Highest supported subindex (Highest subindex supported)	unsigned8	0x04	ro
	0x01	Manufacturer ID (vendor ID)	unsigned32	0x000000AD	ro
	0x02	Device ID (product code)	unsigned32	0x06000002	ro
	0x03	Version number (revision)	unsigned32	0x00000001	ro
	0x04	Serial number	unsigned32	Each read head has its own serial number.	ro

### Object 1C00: Sync Manager Communication Type

This object displays the assignment of the four EtherCAT sync managers.

Index	Subindex	Object name	Description	Data type	Default	Access
0x1C00	0x00	Sync manager	Number of sync managers	unsigned8	0x04	ro
	0x01	Subindex 001	Sync manager type channel 1: Mailbox write permission	unsigned8	0x01	ro
	0x02	Subindex 002	Sync manager type channel 2: Mailbox read permission	unsigned8	0x02	ro
	0x03	Subindex 003	Sync manager type channel 3: Process data write authorization (outputs)	unsigned8	0x03	ro
	0x04	Subindex 004	Sync manager type channel 3: Process data read authorization (inputs)	unsigned8	0x04	ro

### Object 1C12: RxPDO Assignment

Since the read head has no output process data, there is no assignment to an RxPDO object.

Index	Subindex	Object name	Data type	Default	Access
0x1C12	0x00	RxPDO assign	unsigned8	0	rw

### Object 1C13: TxPDO assignment

Object 1C13h can be used to configure a PDO for sync channel 3. Sync channel 3 is fixed for sending transmit PDOs (node → controller). In this object, the number of PDOs assigned to this sync channel must be set under sub-index 0.

The object number of the PDO to be assigned to the channel is entered in subindices 1 to 5. Only the object numbers of the previously configured transmit PDOs can be used here (0x1A10 to 0x1A14).

Index	Subindex	Object name	Description	Data type	Default	Access
0x1C13	0x00	TxPDO assign	Number of assigned TxPDOs	unsigned8	0x05	rw
	0x01	Subindex 001	First assigned TxPDO (contains the index of the corresponding TxPDO mapping object)	unsigned16	0x1A10	rw
	0x02	Subindex 002	Second assigned TxPDO (contains the index of the corresponding TxPDO mapping object)	unsigned16	0x1A11	rw
	0x03	Subindex 003	Third assigned TxPDO (contains the index of the corresponding TxPDO mapping object)	unsigned16	0x1A13	rw
	0x04	Subindex 004	Fourth assigned TxPDO (contains the index of the corresponding TxPDO mapping object)	unsigned16	0x1A14	rw
	0x05	Subindex 005	Fifth assigned TxPDO (contains the index of the corresponding TxPDO mapping object)	unsigned16	0	rw

### Object F000: Modular Device Profile

The modular device profile object contains all the information necessary to interpret the module objects.

Index	Subindex	Object name	Description	Data type	Default	Access
0xF000	0x00	Modular device profile	General information for the modular device profile	unsigned8	0x02	ro
	0x01	Modular index distance	Index distance of the objects of the individual channels	unsigned16	0x0010	ro
	0x02	Maximum number of modules	Number of channels Only one active channel is supported	unsigned16	0x0001	ro

### Object 3000: Pepperl+Fuchs Serial Number

Pepperl+Fuchs standard serial number.

Index	Subindex	Object name	Data type	Default	Access
0x3000	0x00	Pepperl+Fuchs serial number	string	-	ro

## 9.6 Process Data Objects (PDOs)

### PDO Frame

The process data objects (PDOs) are used for the cyclic transfer of process data between the controller and the bus nodes. They must be configured by the controller in the "Pre-Operational" state before operating the bus node. They are transmitted in PDO frames.

To transfer a PDO via the EtherCAT®-CoE protocol, the transmit and receive PDOs (TxPDOs and RxPDOs) must be assigned to a transfer channel of the sync manager in addition to the PDO configuration (PDO mapping). The data exchange of PDOs for the read head takes place exclusively via the EtherCAT® process data telegram protocol.

### PDO Mapping

PDO mapping is used to assign the application objects (real-time process data) from the object directory to the process data objects. For example, the index 0x1A10 from the object directory is reserved for the mapping table of TxPDO1. All mapping objects are predefined and only read access is permitted.

### Overview Modules

The read head supports a slot with three different modules (data structures) of the process data objects. Select one of the three modules in your controller. Module 1 is preset.

#### Module 1—Standard

Index (hex)	Name	Data size	Function	M/Oa/Ou	Link
0x1A10	TxPDO1	1 byte	Status	M	See "TxPDO1—Status" on page 88
0x1A11	TxPDO2	4 bytes	Position binary code	Oa	See "TxPDO2—Position Value Binary Code" on page 88
0x1A12	TxPDO3	4 bytes	Position gray-code	Ou	See "TxPDO3—Position Value Gray Code" on page 89
0x1A13	TxPDO4	1 byte	Speed	Oa	See "TxPDO4—Speed" on page 89
0x1A14	TxPDO5	1 byte	Error codes	Ou	See "TxPDO5—Error Codes" on page 90

- M = Mandatory (always transmitted, not selectable)
- Oa = Optional assigned (selectable, active by default)
- Ou = Optional unassigned (selectable, inactive by default)

## TxPDO1—Status

The mapping object for PDO1 is defined in the object directory under index 0x1A10.

Index	Subindex	Data type	Data size	Offset	Designation	Description
0x6010	0x01	Bit	0.1	0.0	Error	0 = no fault 1 = Error message (error message in PDO 0x1A14)
0x6010	0x02	Bit	0.1	0.1	OUT	0 = read head in code rail 1 = read head partially outside the code rail. No valid position available.
0x6010	0x03	Bit	0.1	0.2	OUT ALL	0 = read head in code rail 1 = read head completely outside the code rail.
0x6010	0x04	Bit	0.1	0.3	DB	Diagnostic bit 0 = by default, the diagnostic bit is not set 1 = read head is dirty
0x6010	0x05	Bit	0.1	0.4	SST	Speed status signals 0 = valid speed 1 = current speed unknown. Last valid speed in SP0 ... SP6 saved
0x6010	0x06 ... 0x08	-	-	-	Reserved	-

## TxPDO2—Position Value Binary Code

The mapping object for PDO3 is defined in the object directory under index 0x1A11.

Index	Subindex	Data type	Data size	Offset	Designation
0x6011	0x01	unsigned32	4	0	Position value binary code

### Content

Endianness: Little-endian  
Resolution: 0.8 mm  
Value range: 0 ... 393204

Position 1 corresponds to 0.8 mm  
Position 1250 corresponds to 1000 mm  
...  
Position 393204 corresponds to 314,563 mm





## TxPDO5—Error Codes

The mapping object for PDO5 is defined in the object directory under index 0x1A14.

Index	Subindex	Data type	Data size	Offset	Designation
0x6013	0x01	unsigned16	1	0	Error code number Only valid if the status error bit is set

### ERR messages

Error	Content	Function
	Byte 1 Status	
0	ERR00	-
1	ERR01	Current position cannot be determined
2	ERR02	Current position cannot be determined
3	ERR03	Fault in the working memory (RAM)
4	ERR04	Fault in the EPROM memory or in the decoder
5	ERR05	Fault in the ROM memory
6	ERR06	-
7	ERR07	-

## Module 2—Position Output

Retrofit structure to ECG110 gateway.

Index (hex)	Name	Data size	Function	M/Oa/Ou	Link
0x1A00	TxPDO1	4 bytes	Item	M	See "TxPDO1—Position" on page 90

- M = Mandatory (always transmitted, not selectable)

## TxPDO1—Position

The mapping object for PDO1 is defined in the object directory under index 0x1A00.

Index	Subindex	Data type	Data size	Offset	Designation	Description
0x6000	0x01	Byte	1	0	Positions byte 0	MSB positions data
0x6000	0x02	Byte	1	1	Positions byte 1	Positions data byte
0x6000	0x03	Byte	1	2	Positions byte 2	LSB positions data
0x6000	0x04	Byte	1	3	Status	Diagnostic byte

Byte/ bit	7	6	5	4	3	2	1	0	Function
1	0	0	0	0	0	XP18	XP17	XP16	Item
2	XP15	XP14	XP13	XP12	XP11	XP10	XP09	XP08	Item
3	XP07	XP06	XP05	XP04	XP03	XP02	XP01	XP00	Item
4	Reserved	Reserved	Reserved	DB	ERR	OUT	Reser ved	Reser ved	Status

**Legend**

Designation	Function
ERR	Error message from read head, Error number in XP00 ... XP04, binary coded.
XP#	Position value in X direction, binary coded with 0.8 mm resolution
OUT	0 = read head in code rail 1 = Read head partially outside the code rail. No valid position available.
DB	Diagnostic bit 0 = by default, the diagnostic bit is not set 1 = read head is dirty

**Module 3—Position and Velocity Output**

Retrofit structure to ECG110 gateway.

Index (hex)	Name	Data size	Function	M/Oa/Ou	Link
0x1A04	TxPDO1	6 bytes	Position and speed	M	See "TxPDO1—Position and Speed" on page 92

- M = Mandatory (always transmitted, not selectable)

## TxPDO1—Position and Speed

The mapping object for PDO1 is defined in the object directory under index 0x1A10.

Index	Subindex	Data type	Data size	Offset	Designation	Description
0x6000	0x01	Byte	1	0	Positions byte 0	MSB positions data
0x6000	0x02	Byte	1	1	Positions byte 1	Positions data byte
0x6000	0x03	Byte	1	2	Positions byte 2	LSB positions data
0x6000	0x05	Byte	1	3	Position and speed status	Position and speed information
0x6000	0x06	Byte	1	4	Zero	Zero byte
0x6000	0x07	Byte	1	5	Speed	Speed value, binary coded [0.1 m/s] 126 > 12.5 m/s 127 = unknown

Byte/bit	7	6	5	4	3	2	1	0	Function
1	0	0	0	0	0	XP18	XP17	XP16	Item
2	XP15	XP14	XP13	XP12	XP11	XP10	XP09	XP08	Item
3	XP07	XP06	XP05	XP04	XP03	XP02	XP01	XP00	Item
4	Reserved	Reserved	SST	DB	ERR	OUT	Reserved	Reserved	Status
5	0	0	0	0	0	0	0	0	Zero
6	SP7	SP6	SP5	SP4	SP3	SP2	SP1	SP0	Speed

### Legend

Designation	Function
ERR	Error message from read head, Error number in XP00 ... XP04, binary coded.
XP#	Position value in X direction, binary coded with 0.8 mm resolution
OUT	0 = read head in code rail 1 = Read head partially outside the code rail. No valid position available.
DB	Diagnostic bit 0 = by default, the diagnostic bit is not set 1 = read head is dirty
SST	Speed status signals 0 = valid speed 1 = current speed unknown. Last valid speed in SP0 ... SP6 saved
SP	Velocity output

## 9.7 Firmware Update via the "File access over EtherCAT®" (FoE) protocol

This chapter describes the firmware update for the read head. The read head supports "File access over EtherCAT®" (FoE). This makes it possible to load the firmware onto the read head via the EtherCAT® controller, provided that it supports this function.

A firmware update should only be carried out after consultation with Pepperl+Fuchs Support.

**Note**

The current firmware version can be downloaded from our website: [www.pepperl-fuchs.com](http://www.pepperl-fuchs.com). Simply enter the product name or item number in the Product/Keyword field and click "Search." Select your product from the list of search results. Click on the information you require in the product information list, for example, Software. A list of all available downloads is displayed.

**Perform the firmware update via TwinCAT**

Proceed as follows with the configuration software TwinCAT 3.x:

1. Download the new firmware locally to your computer.
2. Double-click on "Box 1 (WCS3B-LS710x)" in the project tree.  
↳ The menu "TwinCAT Project 1" is displayed.
3. Click the "Online" tab (1).

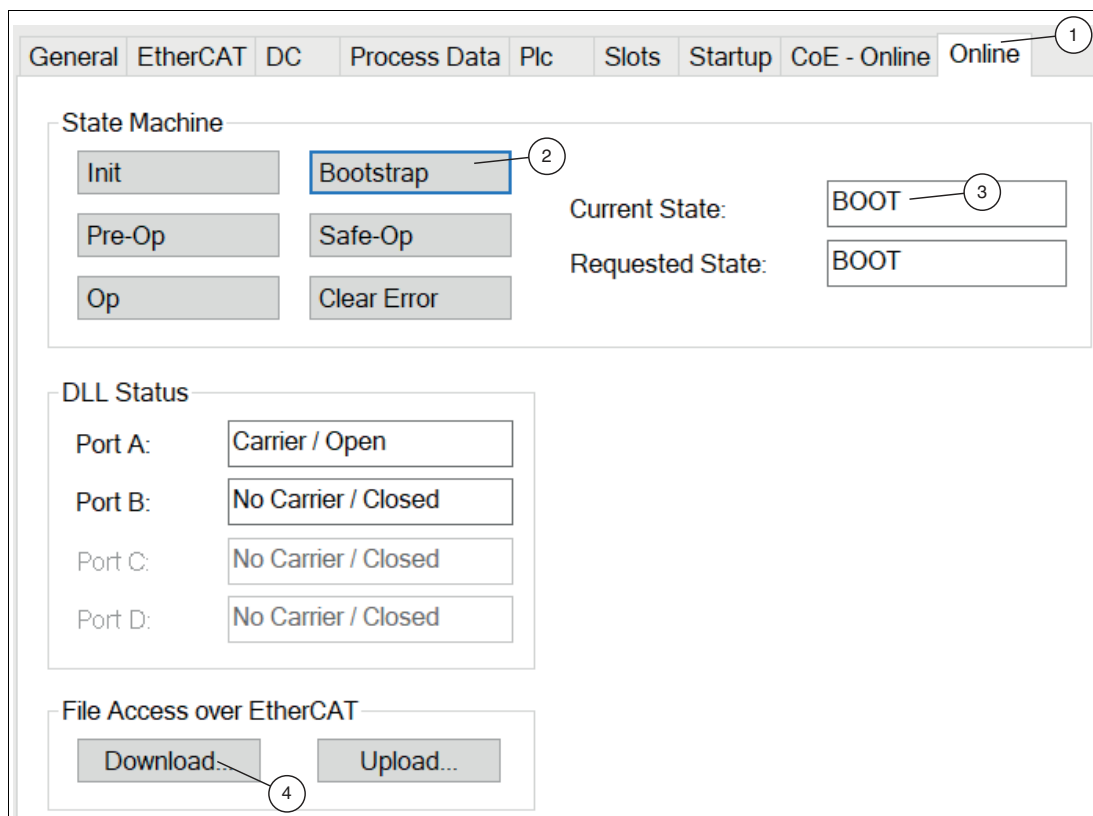

Figure 9.13 State Machine—Bootstrap

↳ The "State Machine" menu opens.

4. Click the "Bootstrap" button (2).  
↳ The read head changes to the "BOOT" status (3).
5. To download the new firmware from the directory, click the "Download" button (4).  
↳ A new window opens, in which you can search for your firmware file. All of the "efw" files (EtherCAT® Firmware) are displayed.
6. Select your firmware file and click "Open" to confirm your selection.  
↳ The "Edit FoE Name" window opens.

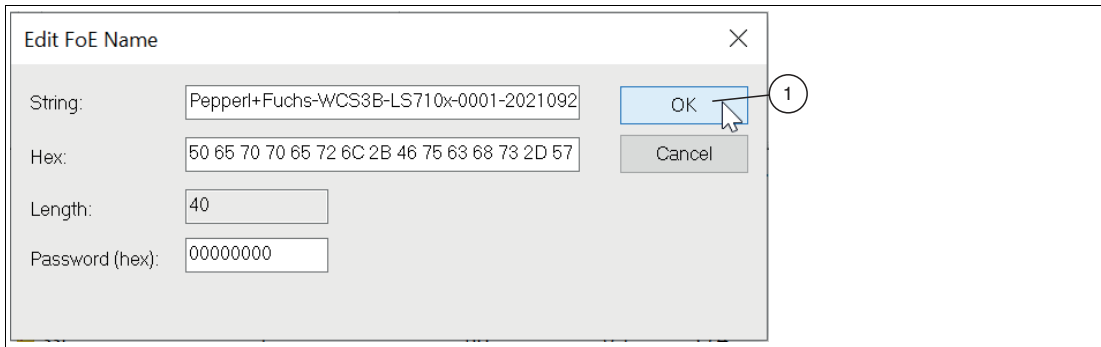

Figure 9.14 Edit the FoE name

7. Confirm the "Edit FoE Name" window with "OK" (1).

↳ The download starts and the firmware file is loaded into the flash memory of the read head. The TwinCAT configuration software displays the download of the firmware file with a progress bar at the bottom of the screen.

8. Click the "Init" button (1).

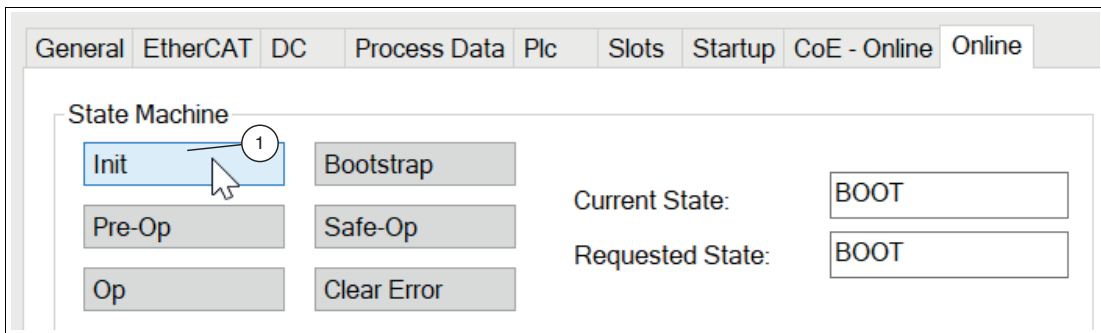
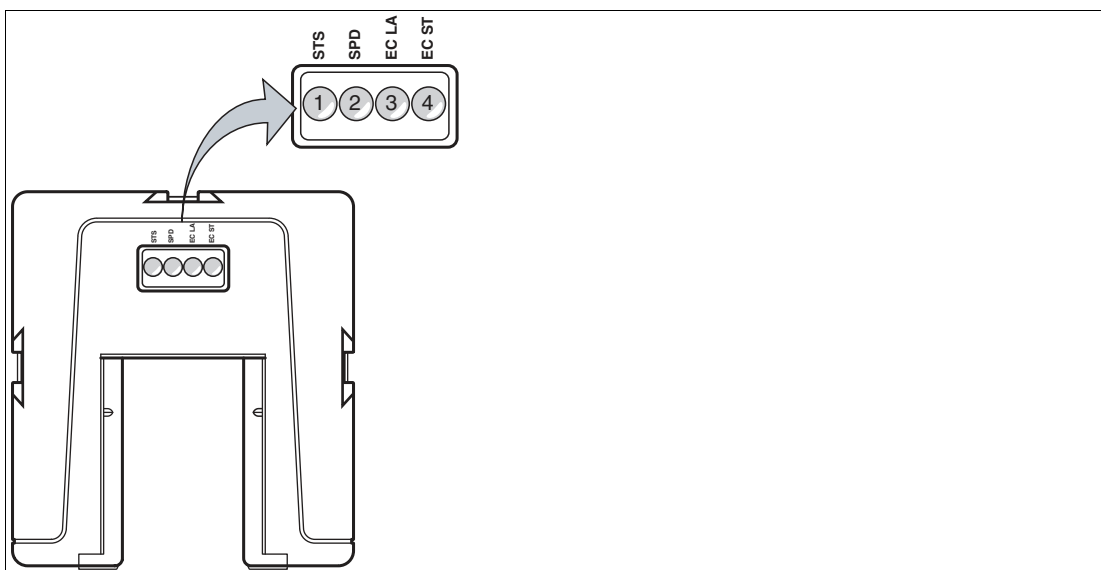

Figure 9.15 State Machine—Init

↳ The update is in progress. When the update is complete, the read head switches to the normal operating mode.

## 9.8 LED Status Indication

### WCS3B-LS7xx\*



**Description of the LED Indicators**

Item	Display	Designation	Color	Display	Meaning
1	STS	Status indicator	green	On	Code rail detected, normal function
			red	On	System error
				Flashing	No code rail detected
2	SPD	Velocity display	Yellow	On	The limit speed has not been met
				Off	The limit speed has been exceeded
3	EC LA	Network connection status (link activity)	green	Flickers	Data transfer in progress
				Off	No network connection
				On	Network connection OK
4	EC ST	Run—Ether-CAT® operating status	green	Off	Device is in the "Initialization" state (normal state after switching on or after a restart).
				Flashing	Device is in the "Pre-Operational" state (configuration of the Ether-CAT® network).
				Easy to light up	Device is in the "Safe-Operational" state (e.g., due to a network malfunction).
				On	The device is in the "Operational" state (normal operating state).
		Error—Ether-CAT® error	red	Off	No errors present.
				Flashing	Config fault No connection to the EtherCAT® network
				Easy to light up	EtherCAT® status change due to an error
				Double lights	Watchdog timeout by the sync manager

**9.9 Trademarks**

EtherCAT® is a registered trademark and patented technology, licensed by Beckhoff Automation GmbH, Germany.



## 10 Options and Special Functions

### 10.1 Option D—Integrated Display in the Read Head, Type LS...D

#### Integrated Display Module

The WCS3B reader can be equipped with an optional display module or can be retrofitted at the factory. During the reader's movements, the display module reports the current position value and any error messages. If the reader has been stationary for more than 15 seconds, the display module issues additional diagnostics data alternately with the position value in a rotating cycle. (See the WCS catalog).

You can rotate the character position on the display 180° using the S1D DIP switch. This allows you to read the displayed values easily regardless of the installation position of the reader.

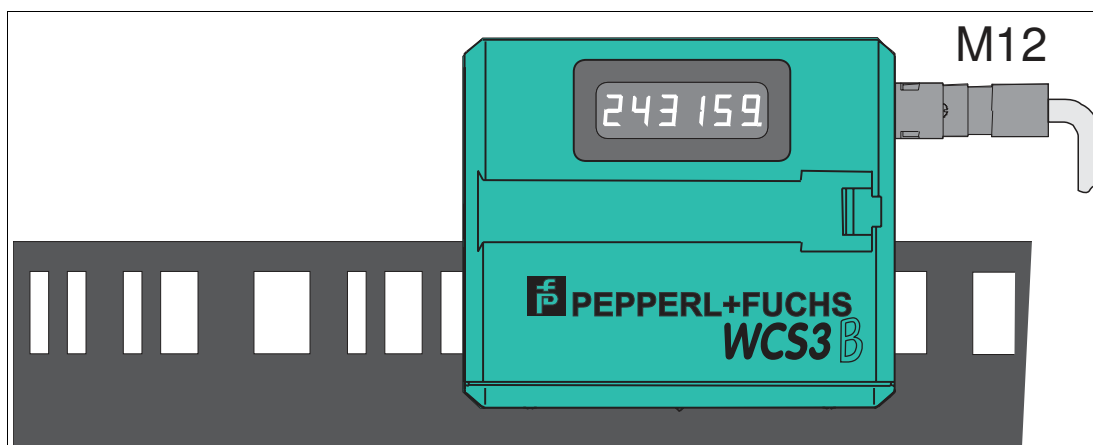

Figure 10.1 Display for a perpendicular code rail (position 0°)

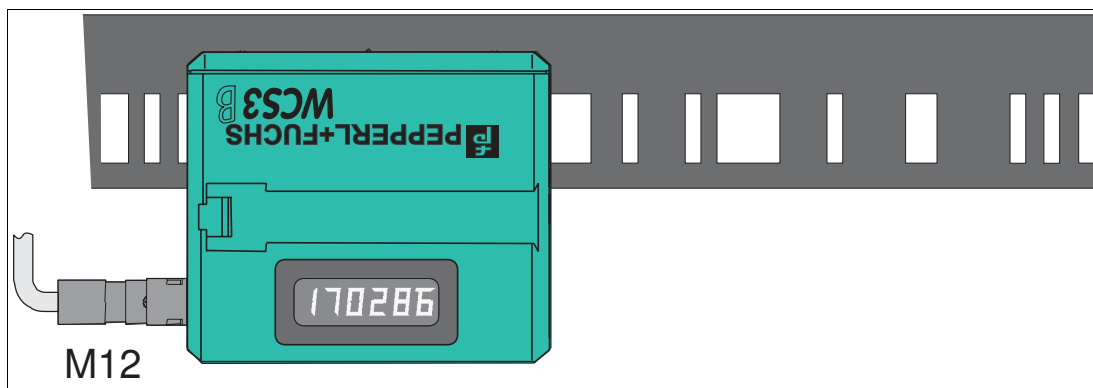

Figure 10.2 Display for a suspended code rail (position 180°)



## Adjusting the display with configuration switch S1D

Display position	S1D		Comment
	1	2	
0°	OFF	OFF	The displayed value can be read on a code rail mounted upright.
180°	ON	ON	The displayed value can be read on a code rail mounted suspended.



### Note

The set display position is not noted on the nameplate of the read head.

## Overview of the display module

The display shows the current position value. After switching on the read head, the following information is displayed in sequence:

**read head type**, e.g., "LS-221"

**read head address**, e.g., "Addr 0"

**software version**, e.g., "Pr. 1.01"

When at a standstill, the read head switches to the "information display" mode. The following data is displayed cyclically:

"12.34.56," internal clock (hh.mm.ss)

"Good" or "bad"

Condition of the lens/photoelectrics:

"LE - - -," No error message

"LE 1," Read head has detected error 1

"Lo ---," Read head was not outside the code rail

"Lo 34," Read head was outside the code rail 34 times

"LS ---," Limit speed has not been exceeded

"LS 128," Limit speed was exceeded 128 times (only for read head with option "velocity output")



### Note

All values are reset after the voltage is switched on. The maximum time is 99:59:59, then the time starts again at 00:00:00. The maximum counter values for Lo and LS are 255.

## 10.2 Option-E—Extended, Type WCS3B-LS\*E\*, RS-485

For travel distances greater than 314.573 m, the read head **WCS3-Extended: WCS3B-LS\*E\*** with RS-485 interface is used. In this case, the additional "E" in the type code identifies the extended version for the extending code rail. Two standard code rail segments with a length of 0 ... 314.573 m are connected to each other with the WCS3-CS70-E code rail extender to achieve a maximum code rail length of up to 629.146 m. The first code rail segment must always be complete, or end with the position at 314.573 m. The second code rail segment can have a shorter length of 314.573 m to X m, but must be used in descending position, starting at 314.573 m.

### Extended data protocol with position output

Request byte for read head									
Byte	Bit 8	Bit 7	Bit 6	Bit 5	Bit 4	Bit 3	Bit 2	Bit 1	Bit 0
	1	0	1	1	0	0	1	A1	A0

Response telegram from the read head									
Byte	Bit 8	Bit 7	Bit 6	Bit 5	Bit 4	Bit 3	Bit 2	Bit 1	Bit 0
Byte 1	0	A1	A0	OVL	/VAL	DB	OUT ALL	OUT	ERR
Byte 2	0	0	0	0	0	XP19	XP18	XP17	XP16
Byte 3	0	XP15	XP14	XP13	XP12	XP11	XP10	XP09	XP08
Byte 4	0	XP07	XP06	XP05	XP04	XP03	XP02	XP01	XP00
Byte 5	0	xor B1.7 ... B4.7	xor B1.6 ... B4.6	xor B1.5 ... B4.5	xor B1.4 ... B4.4	xor B1.3 ... B4.3	xor B1.2 ... B4.2	xor B1.1 ... B4.1	xor B1.0 ... B4.0

### Data protocol with position and velocity output

Request byte for read head									
Byte	Bit 8	Bit 7	Bit 6	Bit 5	Bit 4	Bit 3	Bit 2	Bit 1	Bit 0
	1	1	1	1	0	0	1	A1	A0

Response telegram from the read head									
Byte	Bit 8	Bit 7	Bit 6	Bit 5	Bit 4	Bit 3	Bit 2	Bit 1	Bit 0
Byte 1	0	A1	A0	OVL	/VAL	DB	OUT ALL	OUT	ERR
Byte 2	0	0	0	0	0	XP19	XP18	XP17	XP16
Byte 3	0	XP15	XP14	XP13	XP12	XP11	XP10	XP09	XP08
Byte 4	0	XP07	XP06	XP05	XP04	XP03	XP02	XP01	XP00
Byte 5	0	SST	SP6	SP5	SP4	SP3	SP2	SP1	SP0
Byte 6	0	B1.7 ... B5.7	B1.6 ... B5.6	B1.5 ... B5.5	B1.4 ... B5.4	B1.3 ... B5.3	B1.2 ... B5.2	B1.1 ... B5.1	B1.0 ... B5.0

## Description of the protocol data

### Byte 1

<b>A1, A0</b>		Address bits of the read head. Addresses 0 ... 3, binary coding
<b>OVL</b>	0	The read head is located in the readable area of the code rail
	1	The read head is located on WCS3 code rail extender (overlapping area of the code rail segments)
<b>VAL</b>	0:	Position valid
	1	Position invalid; code rail area is not unique after the supply voltage has been connected
<b>DB</b>	0	By default, the diagnostic bit is not set
	1	Diagnostic bit, read head dirty
<b>OUT ALL</b>	0	Read head in code rail
	1	Read head completely outside of the code rail
<b>OUT</b>	0	Read head in code rail
	1	Read head partially outside the code rail No valid position available
<b>ERR</b>	0	No error
	1	Error message (possible errors in XP00 ... XP01 binary coding)

### Byte 2 ... 4

**XP00 ... XP19** Current position value, binary coding

### Byte 5 <sup>1</sup>

<b>SP0 ... SP6</b>		Current speed in 0.1 m/s, binary coding For example: <ul style="list-style-type: none"> <li>• 1: Speed = 0.1 m/s</li> <li>• 37: Speed = 3.7 m/s</li> <li>• 112: Speed = 11.2 m/s</li> </ul>
<b>SST</b>	0	Speed valid
	1	Current speed unknown. Last valid speed in SP0 ... SP6 saved

**Byte 5/6** Exclusive or link, byte 1 ... Byte 4/5

1. For data protocol with velocity output

## Behavior of the read head in the area of the WCS3 code rail extender (WCS3-CS70-E)

The read head retains the last measured end position of the first code rail segment (position = 393203) when traversing the WCS3 code rail extender. The OVL bit is set at the same time. As soon as the first valid position of the second code rail segment is read, the read head switches to the first valid position of the second code rail segment (position = 393318). The first valid position of the second code rail segment is dimensioned with an offset of approx. + 92 mm. (see area highlighted in yellow in the figure below.)

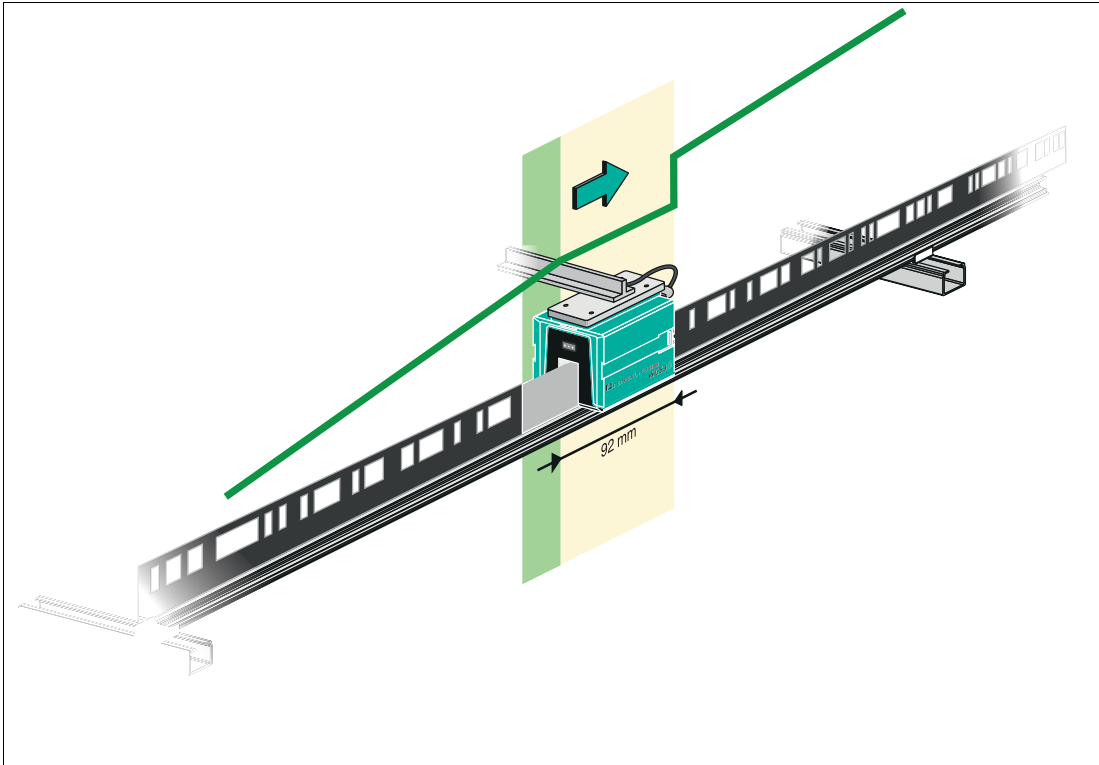

### Caution!

Impermissible state

If you mount the WCS3 code rail extender in the wrong position, e.g., at an intermediate position of the code rail, the OUT bit is set when this code rail segment is crossed.



### Note

#### Cycle time

Note that the cycle time for the extended variant differs from the standard variant by  $t = 10$  ms.

## Start-up behavior of the read head

After the supply voltage has been connected, the X position is set to the last valid X position and the VAL bit is set to 1.

The speed value is 127 and the SST bit is set to 1.

After the read head moves by approx. 5 mm, the VAL bit is set to 0 and the X position is assigned a new calculated X position. The last valid X position is stored in a non-volatile memory if it is detected that the voltage is switched off ( $+U_b < 9.9$  VDC).

### 10.3 Option-H—Heating in Read Head, Type LS...H

For applications with a risk of condensation (quick temperature change from cold to hot, high relative humidity), the WCS read head can be equipped with an optional **heater**. The heating is supplied via the read head, i.e., no additional electrical connection is required for the heating. Ensure that the cross section of the supply line to the read head is sufficiently dimensioned.

The **heater** is switched on immediately after the voltage is connected to the read head. The power consumption is 7 VA for the WCS2B and 9 VA for the WCS3B. The WCS3B heater uses a regulator that automatically switches off the heater at a temperature above 60 °C, measured at the transparent protective lenses of the read head.

With the **heater** option, the read head can be used in the temperature range of -40 °C ... 60 °C.

### 10.4 Option-S—Velocity Output, Type LS...S

The WCS3B read head with velocity output features an additional 24 VDC output, which transmits a signal in the event that a limit speed is exceeded. The limit speed can be configured on the 4-way DIP switch in the read head. The limit speed is set to 0.7 m/s on delivery.

#### Setting the limit speed (option -S only)

Limit speed $v_{limit}$	S1			
	1	2	3	4
0.7 m/s	X	X	OFF	OFF
2.0 m/s	X	X	OFF	ON
3.0 m/s	X	X	ON	OFF
4.0 m/s	X	X	ON	ON

The limit speed is output digitally via pin 5 of the 5-pin M12 connector:

$U_v$  (pin 5) = operating voltage  $U_B \rightarrow v_{current} < v_{limit}$

$U_v$  (pin 5) = floating (high impedance)  $\rightarrow v_{current} \geq v_{limit}$



#### Note

##### LED status indicator on the WCS3B read head with velocity output

The WCS3B read head has three LEDs on the front. The meaning of the yellow LED is changed according to the speed setting.

**Illuminated yellow:** Limit speed not exceeded

**Not illuminated yellow:** Limit speed exceeded

**Flashing red:** Read head outside the code rail or read head dirty



#### Note

The set limit speed is not noted on the nameplate of the read head.

## 11 Model Overview for WCS Read Heads

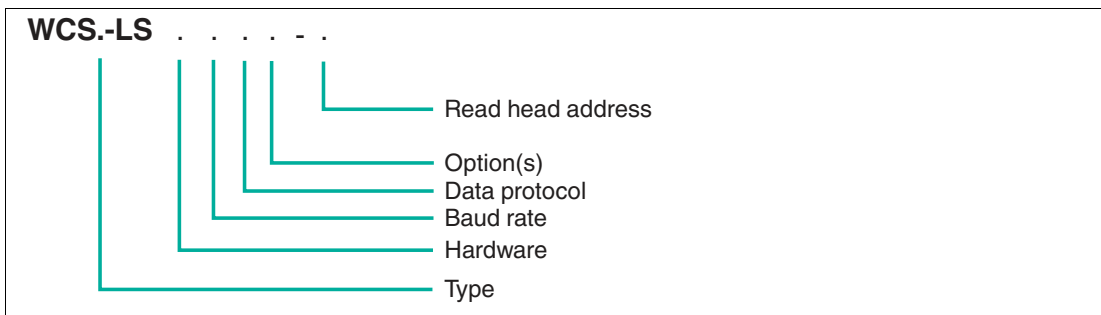

Type		
	2B	WCS2B read head (smaller enclosure, 1200 pos./m with a maximum of 327 m)
	3B	WCS3B read head (1250 pos./m with a maximum of 314.573 m)
	3R	WCS3R read head (833 pos./m with a maximum of 39.3 m)
	3T	WCS3T read head (416 pos./m with a maximum of 78.6 m)

Hardware		
	1	Read head with RS-485 interface, no RS-485 terminator
	2	Read head with RS-485 interface, with RS-485 terminator
	3	Read head with SSI interface
	4	Read head with CANopen interface
	5	Read head with EtherNet/IP interface
	6	Read head with PROFINET Interface
	7	Read head with EtherCAT interface

Baud rate		
	Read head with RS-485 interface	
	1	187.50 kBaud
	2	62.50 kBaud
	3	31.25 kBaud
	4	19.20 kBaud
	5	9.60 kBaud
	6	38.40 kBaud
	Read head with SSI interface	
	1	100 kHz – 1000 kHz
	Read head with CANopen interface	
	1	125 kBaud, 250 kBaud, 500 kBaud, 1 MBaud
	Read head with EtherNet/IP interface	
	1	100 Mbit/s
	Read head with PROFINET Interface	
	1	100 Mbit/s
	Read head with EtherCAT interface	
	1	100 Mbit/s

2022-02

<b>Data log</b>	Read head with RS-485 interface	
	1	Data log 1, data log 2 <sup>1</sup>
	6	Data log 3 with even parity (9 bit/byte)
	7	Data log 3 without parity (8 bit/byte)
	Read head with SSI interface	
	0	Data output in binary code
	1	Data output in Gray code
	Read head with CANopen, EtherNet/IP, PROFINET, and EtherCAT interfaces	
	0	Data output in binary code

1. Data log depends on read head request byte

<b>Option</b>	D	Read head with optional integrated display
	E	Read head with "Extended" option
	H	Read head with optional heating
	S	Read head with optional velocity output
	OM	Read head with "Outdoor" option (IP69K) and central cable outlet
	OL	Read head with "Outdoor" option (IP69K) and left-hand-side cable outlet
	OR	Read head with "Outdoor" option (IP69K), and right-hand-side cable outlet

<b>Read head address</b>	Read head with RS-485 interface	
	0	Read head address 0
	1	Read head address 1
	2	Read head address 2
	3	Read head address 3
	-	Read head address 0

## 12 Disposal

The device, built-in components, packaging, and any batteries contained within must be disposed in compliance with the applicable laws and guidelines of the respective country.



## 13 Appendix

### 13.1 Cable Overview

The cable types listed below represent a selection of the types available from Pepperl+Fuchs. You can find additional cable types on our website.



#### Note

For customizable cables, observe the cable length restrictions specified by the interface specifications. Refer to the relevant interface chapters for maximum cable length recommendations.

#### RS-485 (LS1xx\*, LS2xx\*)

Cable	Description
<b>Field attachable cable</b>	
V15-G-2M-PUR-ABG	M12 single-ended female cordset, 5-pin, straight, 2 m PUR cable, shielded
V15-G-5M-PUR-ABG	M12 single-ended female cordset, 5-pin, straight, 5 m PUR cable, shielded
V15-G-10M-PUR-ABG	M12 single-ended female cordset, 5-pin, straight, 10 m PUR cable, shielded
<b>Field attachable single-ended female cordsets and available by the meter</b>	
V15-G-ABG-PG9	Five-pin single-ended female cordset, field attachable, shielded
V15-G-ABG-PG9-FE	Five-pin single-ended female cordset, field attachable, shielded with grounding terminal
WCS-DCS	Available by the meter, 6-pin data cable + shield, 0.14 mm <sup>2</sup> 3 x 2 twisted pair wire
WCS-DCF	Available by the meter, 6-pin data cable + shield, 0.25 mm <sup>2</sup> 3 x 2 twisted pair wire, suitable for drag chains

#### SSI (LS3xx\*)

Cable	Description
<b>Field attachable cable</b>	
V19-G-2M-PUR-ABG	M12 single-ended female cordset, 8-pin, straight, 2 m PUR cable, shielded
V19-G-5M-PUR-ABG	M12 single-ended female cordset, 8-pin, straight, 5 m PUR cable, shielded
V19-G-10M-PUR-ABG	M12 single-ended female cordset, 8-pin, straight, 10 m PUR cable, shielded
V19-G-2M-PVC-TP	Single-ended female cordset, M12, 8-pin, shielded, 2 m PVC cable shielded and twisted in pairs
V19-G-5M-PVC-TP	Single-ended female cordset, M12, 8-pin, shielded, 5 m PVC cable shielded and twisted in pairs
V19-G-10M-PVC-TP	Single-ended female cordset, M12, 8-pin, shielded, 10 m PVC cable shielded and twisted in pairs
<b>Field attachable single-ended female cordsets and available by the meter</b>	
V19-G-ABG-PG9	Eight-pin single-ended female cordset, field attachable, shielded
V19-G-ABG-PG9-FE	Eight-pin single-ended female cordset, field attachable, shielded with grounding terminal

Cable	Description
WCS-DCS	Available by the meter, 6-pin data cable + shield, 0.14 mm <sup>2</sup> 3 x 2 twisted pair wire
WCS-DCF	Available by the meter, 6-pin data cable + shield, 0.25 mm <sup>2</sup> 3 x 2 twisted pair wire, suitable for drag chains

**CANopen (LS4xx\*)**

Cable	Description
<b>Field attachable cable</b>	
V15-G-2M-PUR-CAN	CANOpen bus cable, M12 to open cable end, 2 m PUR cable, 5-pin
V15-G-2M-PUR-CAN-V15-G	CANOpen bus cable, M12 to M12, 2 m PUR cable, 5-pin
V15-G-5M-PUR-CAN-V15-G	CANOpen bus cable, M12 to M12, 5 m PUR cable, 5-pin
V15-G-10M-PUR-CAN-V15-G	CANOpen bus cable, M12 to M12, 10 m PUR cable, 5-pin
<b>Field attachable single-ended female cordsets and available by the meter</b>	
V15-G-ABG-PG9-FE	M12 single-ended female cordset, 5-pin, shielded, field-attachable
WCS-DCS	Available by the meter, 6-pin data cable + shield, 0.14 mm <sup>2</sup> 3 x 2 twisted pair wire
WCS-DCF	Available by the meter, 6-pin data cable + shield, 0.25 mm <sup>2</sup> 3 x 2 twisted pair wire, suitable for drag chains

**EtherNet/IP (LS5xx\*), PROFINET (LS6xx\*) & EtherCAT (LS7xx\*)**

Cable	Description
<b>Hybrid cable with shared data line and supply voltage</b>	
V19SY-G-BK2M-PUR-ABG	Hybrid cable, M12, 8-pin, Y coding, 2 m PUR cable, shielded
V19SY-G-BK5M-PUR-ABG	Hybrid cable, M12, 8-pin, Y coding, 5 m PUR cable, shielded
V19SY-G-BK10M-PUR-ABG	Hybrid cable, M12, 8-pin, Y coding, 10 m PUR cable, shielded
<b>Y-splitter and cable (data line and supply voltage separate)</b>	
V19SY-Y-V1D/V1S	Y-splitter, M12 plug Y-coded to A-coded M12 plug/D-coded socket
V1SD-G-*M-PUR-ABG-V45-G <sup>1</sup>	Cordset, M12 to 4-pin RJ45 PUR cable, CAT5e, in conjunction with Y-plug (data cable)
V1-G-BK10M-PUR-U	Single-ended female cordset, M12, four pins, PUR cable in conjunction with Y-plug (supply voltage)

1. This type of cable is available in different lengths of 2 ... 45 m.

# Your automation, our passion.

## Explosion Protection

- Intrinsic Safety Barriers
- Signal Conditioners
- FieldConnex® Fieldbus
- Remote I/O Systems
- Electrical Ex Equipment
- Purge and Pressurization
- Industrial HMI
- Mobile Computing and Communications
- HART Interface Solutions
- Surge Protection
- Wireless Solutions
- Level Measurement

## Industrial Sensors

- Proximity Sensors
- Photoelectric Sensors
- Industrial Vision
- Ultrasonic Sensors
- Rotary Encoders
- Positioning Systems
- Inclination and Acceleration Sensors
- Fieldbus Modules
- AS-Interface
- Identification Systems
- Displays and Signal Processing
- Connectivity

### Pepperl+Fuchs Quality

Download our latest policy here:

[www.pepperl-fuchs.com/quality](http://www.pepperl-fuchs.com/quality)

