

SIEMENS

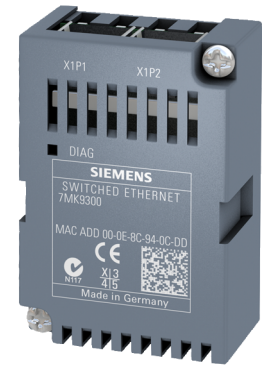

SWITCHED ETHERNET PROFINET expansion module
 Erweiterungsmodule SWITCHED ETHERNET PROFINET
 Module d'extension SWITCHED ETHERNET PROFINET
 Módulo de ampliación SWITCHED ETHERNET PROFINET
 Modulo di ampliamento SWITCHED ETHERNET PROFINET
 Módulo de expansão SWITCHED ETHERNET PROFINET
 SWITCHED ETHERNET PROFINET genişletme modülü
 Модуль расширения SWITCHED ETHERNET PROFINET
 Moduł rozszerzenia SWITCHED ETHERNET PROFINET
 交换式以太网 PROFINET 扩展模块



7KM9300-0AE01-0AA0
 7KM9300-0AE02-0AA0



Operating Instructions Betriebsanleitung Notice d'utilisation Instructivo Istruzioni operative
 Instruções de Serviço İşletme kılavuzu Руководство по эксплуатации Instrukcja obsługi 使用说明

		EN	DANGER Hazardous voltage. Will cause death or serious injury. Turn off and lock out all power supplying this device before working on this device.	
		NOTICE	Installation and maintenance must be carried out by qualified personnel.	
DE	GEFAHR Gefährliche Spannung. Lebensgefahr oder schwere Verletzungsgefahr. Bevor Arbeiten am Gerät durchgeführt werden, müssen alle Stromquellen ausgeschaltet und mit einer Einschaltssicherung versehen werden.	FR	DANGER Tension électrique dangereuse. Danger de mort ou risque de blessures graves. Avant d'intervenir sur l'appareil, couper toutes les sources de tension et les consigner contre la refermeture.	
HINWEIS	Installations- und Wartungsarbeiten sind von qualifiziertem Personal durchzuführen.	NOTIFICATION	L'installation et la maintenance doivent être effectuées uniquement par des personnes qualifiées.	
ES	PELIGRO Tensión peligrosa. Puede causar la muerte o lesiones graves. Antes de trabajar en este dispositivo, desconecte y bloquee todas las fuentes que lo alimentan eléctricamente.	IT	PERICOLO Tensione pericolosa. Può causare la morte o lesioni gravi. Prima di lavorare su questa apparecchiatura, disinserire tutte le fonti di alimentazione elettrica dell'apparecchiatura ed assicurarle contro la reinserzione.	
NOTA	La instalación y el mantenimiento deben corre a cargo de personal cualificado.	NOTA	L'installazione e la manutenzione devono essere eseguite da personale qualificato.	
PT	PERIGO Tensão perigosa. Perigo de morte ou ferimentos graves. Desligue e bloqueie todas as fontes de alimentação antes de executar quaisquer trabalhos no aparelho.	TR	TEHLİKE Tehlikeli gerilim. Ölüm tehlikesi veya ağır yaralanma tehlikesi mevcuttur. Cihazda çalışmalar yapılmadan önce, tüm güç kaynakları kapatılmalı ve bir açma emniyetiyle donatılmalıdır.	
ATENÇÃO	A instalação e manutenção têm de ser efetuadas por pessoal qualificado.	NOT	Montaj ve bakım işlemleri kalifiye personel tarafından yapılmalıdır.	
РУ	ОПАСНО Опасное напряжение. Опасность для жизни или телесных повреждений. До начала работы выключите и заблокируйте все источники питания этого устройства.	PL	ZAGROŻENIE Niebezpieczne napięcie. Niebezpieczeństwo poważnych obrażeń lub utraty życia. Wyłączyc i zablokować wszystkie źródła zasilania urządzenia przed rozpoczęciem pracy na urządzeniu.	
ПРИМЕЧАНИЕ	Установка и техническое обслуживание должны производиться квалифицированным персоналом.	UWAGA	Instalacja i konserwacja muszą być wykonywane przez wykwalifikowany personel.	

Technical Support:

Internet: <https://www.siemens.com/support-request>

中	 危险	HR	 OPASNOST
危险电压。可能导致生命危险或重伤危险。 操作此设备前必须确保切断其电源并采取防接通保护措施。		Opasni napon. Opasnost po život ili opasnost od teških ozljeda. Prije rada na uređaju potrebno je isključiti sve izvore struje i osigurati uređaj zaštitom od uključivanja.	
	注意 安装和维护必须由具备专业资质的人员进行。		НАПОМЕНА Montažu i održavanje treba obavljati kvalificirano osoblje.
FI	 VAARA	БГ	 ОПАСНОСТ
Vaarallinen jännite. Vakava loukkaantumisvaara tai hengenvaara. Laitteen kaikki virransyöttö tulee katkaista ja sen kytkeytyminen päälle tulee estää lukolla ennen kuin laitteeseen kohdistetaan mitään toimenpiteitä.		Опасно напряжение. Опасност за живота или опасност от тежки телесни повреди. Преди да извършвате дейности по устройството, изключете и обезопасете всички хранващи източници.	
	HUOMAUTUS Asennus- ja huoltotyöt on annettava pätevän ammattilaisen suoritettaviksi.		ПРЕДУПРЕЖДЕНИЕ Инсталирането и поддръжката трябва да се извършват от квалифициран персонал.
EE	 OHT	LV	 BĪSTAMI
Ohtlik pinge. Oht elule või raskete vigastuste oht. Enne seadme hooldustöid lülitage kõik toiteallikad välja ja võtke meetmed nende sisselülitamise takistamiseks.		Bīstams spriegums. Letālu seks vai smagu traumu risks. Pirms veicat darbu ar šo ierīci pilnībā izslēdziet un nobloķējiet tās strāvas padevi.	
	MÄRKUS Paigaldus- ja hooldustöid tohib teha ainult kvalifitseeritud personal.		BRĪDINĀJUMS Uzstādīšana un tehniskā apkope jāveic kvalificētiem darbiniekiem.
LT	 PAVOJUS	DA	 FARE
Pavojiną įtampa. Pavojus gyvybei arba sunkaus susižalojimo pavojus. Prieš dirbdami ties šiuo prietaisu, išjunkite ir užblokuokite visus šio prietaiso maitinimo šaltinius.		Farlig spænding. Livsfare eller risiko for slemme kvæstelser. Sluk for og lås strømmen, der forsyner denne enhed, før du arbejder med denne enhed.	
	NUORODA Įrengimą ir techninę priežiūrą turi vykdyti kvalifikuoti darbuotojai.		BEMÆRK Installationen og vedligeholdelsen skal foretages af uddannet personale.
MT	 PERIKLU	NL	 GEVAAR
Vultaġġ perikoluż. Riskju ta' mewt jew korriment serju. Qabel taħdem fuq dan l-apparat, itfi kull provvista tal-elettriku tiegħu u sakkar kontra xegħil mill-ġdid aċċidentali.		Gevaarlijke spanning. Levensgevaar of gevaar voor ernstig letsel. Voordat u aan dit apparaat werkt, moet u alle actieve energiebronnen voor dit apparaat uitschakelen.	
	AVVIŻ L-installazzjoni u l-manutenzjoni għandhom jitwettqu minn persunal ikkwalifikat.		OPMERKING Installatie en onderhoud moeten worden verricht door gekwalificeerd personeel.
EL	 ΚΙΝΔΥΝΟΣ	GA	 CONTÚIRT
Επικίνδυνη τάση. Κίνδυνος για τη ζωή ή σοβαρού τραυματισμού. Απενεργοποιήστε και ασφαλίστε όλη την ενέργεια που τροφοδοτεί τη συσκευή, προτού εργαστείτε σε αυτή.		Voltas contúirteach. Baol go bhfaighfear bás nó tromghortú. Múch gach cumhacht a sholáthraíonn an gléas seo agus glasáil amach í roimh obair a dhéanamh ar an ngléas seo.	
	ΠΡΟΣΟΧΉ Η εγκατάσταση και συντήρηση πρέπει να διεξάγονται από εξειδικευμένο προσωπικό.		FÓGRA Ní mór don fheistiú agus don chothabháil a bheith déanta ag pearsanra cáilithe.
RO	 PERICOL	SV	 FARA
Tensiune periculoasă. Pericol de moarte sau de accidentări grave. Opriti și blocați alimentarea cu energie a acestui dispozitiv înainte de a lucra la acesta.		Farlig spänning. Livsfara eller risk för allvarliga personskador. Innan arbete utförst på utrustningen ska strömförsörjningen till utrustningen stängas av.	
	ÎNȘTIINȚARE Instalarea și întreținerea trebuie să se efectueze de către personalul calificat.		OBS Installation och underhåll får endast utföras av kvalificerad personal.
CZ	 NEBEZPEČÍ	SL	 NEVARNOST
Nebezpečné napětí. Nebezpečí smrtelného nebo těžkého úrazu. Před zahájením prací na tomto zařízení odpojte a zajistěte veškeré přírůdy energie.		Nevarna napetost. Nevarnost za življenje ali nevarnost hudih poškodb. Izklopite in prekinite celotno napajanje naprave, preden na njej opravljate dela.	
	POZNÁMKA Instalaci a údržbu musí provádět kvalifikovaní pracovníci.		OPOMBA Namestitev in vzdrževanje mora opraviti usposobljeno osebje.
SK	 NEBEZPEČENSTVO	HU	 VESZÉLY
Nebezpečné napätie. Nebezpečenstvo ohrozenia života alebo vzniku ťažkých zranení. Pred prácou na zariadení vypnite a zaistíte všetky napájacie prípojky tohto zariadenia.		Veszélyes feszültség. Életveszély vagy súlyos sérülésveszély. Mielőtt bármilyen munkavégzést kezd az eszközön, az áramellátást le kell kapcsolni, és véletlen bekapcsolás elleni védelemmel kell ellátni.	
	UPOZORNENIE Inštaláciu a údržbu musí vykonávať kvalifikovaný personál.		MEGJEGYZÉS A telepítést és a karbantartást kizárólag szakképzett személyzet végezheti.



EN

⚠ DANGER

Hazardous voltage. Will cause death or serious injury. Turn off and lock out all power supplying this device before working on this device. Replace all covers before power supplying this device is turned on.

ES

⚠ PELIGRO

Tensión peligrosa. Puede causar la muerte o lesiones graves. Antes de trabajar en este dispositivo, desconecte y bloquee todas las fuentes que lo alimentan eléctricamente. Recoloque todas las cubiertas antes de volver a conectar la alimentación eléctrica para este dispositivo.

FR

⚠ DANGER

Tension électrique dangereuse. Danger de mort ou risque de blessures graves. Avant d'intervenir sur l'appareil, couper toutes les sources de tension et les consigner contre la refermeture. Remettez en place tous les couvercles avant de remettre l'appareil sous tension.



Contents / Lieferumfang / Etendue de la livraison / Contenido / 供货范围

Required tools / Notwendige Werkzeuge / Outils nécessaires / Herramientas requeridas / 必要工具

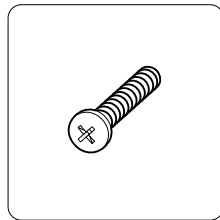
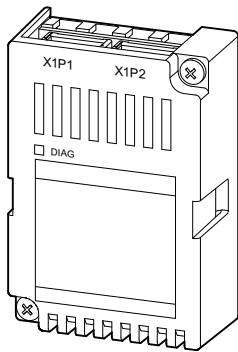

powerconfig



<https://sie.ag/3m5fSbi>



Assembly / Montage / Montage / Montaje / 安装



7KM PAC3200
7KM PAC3220
7KM PAC4200

3VA COM100
3VA COM800

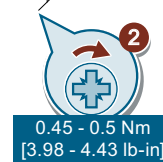
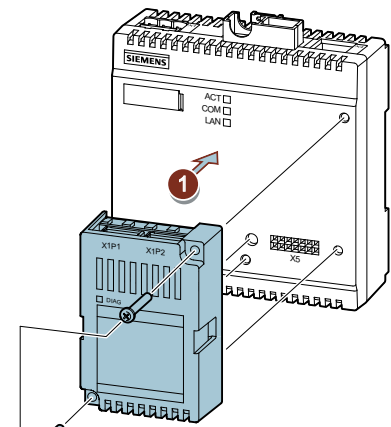
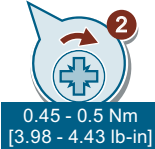
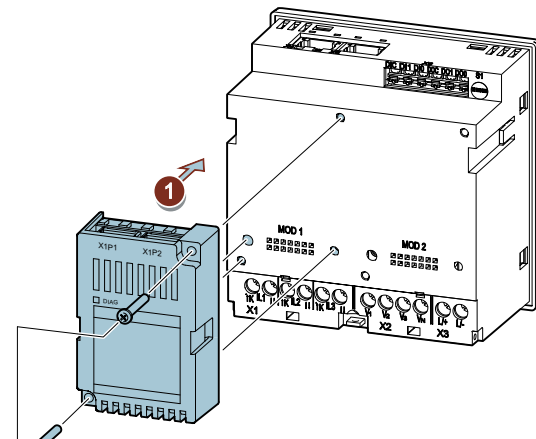

	7KM PAC3200	7KM PAC3220	7KM PAC4200	3VA COM100	3VA COM800
7KM9300-0AE01-0AA0	✓	—	✓	✓	✓
7KM9300-0AE02-0AA0	✓	✓	✓	✓	✓



Connection / Anschluss / Raccordement / Conexión / 连接

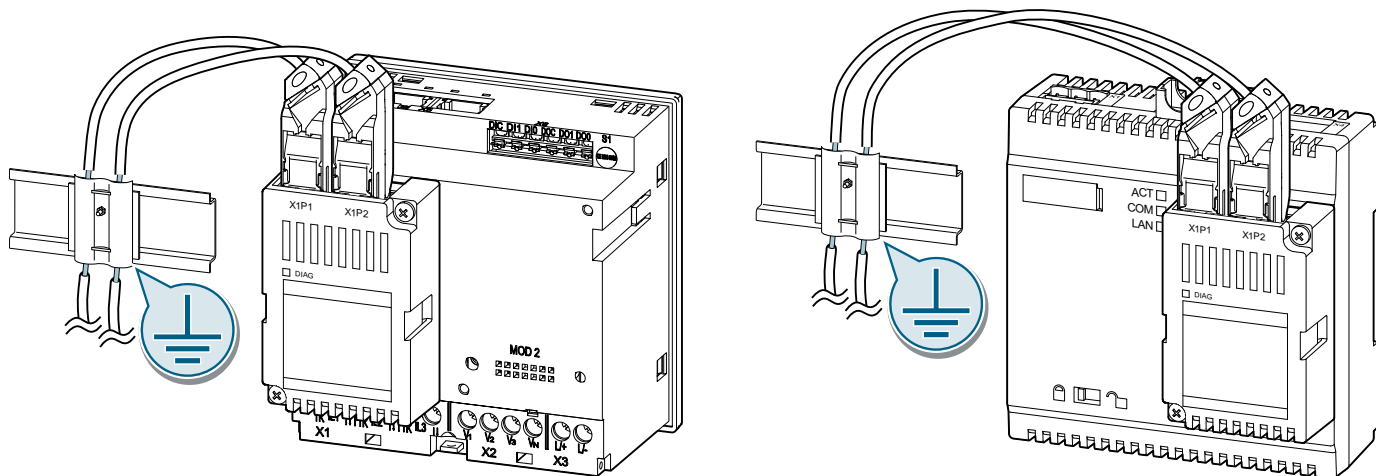

PAC3200



www.siemens.com/lowvoltage/manuals

PAC3220



www.siemens.com/lowvoltage/manuals

PAC4200



www.siemens.com/lowvoltage/manuals

3VA COM100 / 3VA COM800







www.siemens.com/lowvoltage/manuals

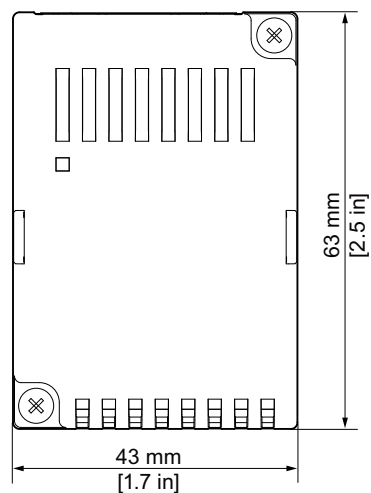
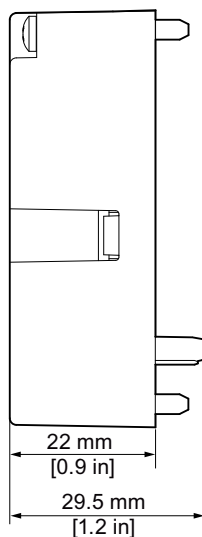

Information / Information / Informations / Información / 信息



		EN  DANGER
		Hazardous voltage. Will cause death or serious injury. Turn off and lock out all power supplying this device before working on this device. Replace all covers before power supplying this device is turned on.
ES  PELIGRO	FR  DANGER	
Tensión peligrosa. Puede causar la muerte o lesiones graves. Antes de trabajar en este dispositivo, desconecte y bloquee todas las fuentes que lo alimentan eléctricamente. Recoloque todas las cubiertas antes de volver a conectar la alimentación eléctrica para este dispositivo.		Tension électrique dangereuse. Danger de mort ou risque de blessures graves. Avant d'intervenir sur l'appareil, couper toutes les sources de tension et les consigner contre la refermeture. Remettez en place tous les couvercles avant de remettre l'appareil sous tension.

	Information / Information / Informations / Información / 信息	
---	--	---

EN <i>Security information</i>	DE <i>Securityhinweise</i>
In order to protect plants, systems, machines and networks against cyber threats, it is necessary to implement – and continuously maintain – a holistic, state-of-the-art industrial security concept. Siemens' products and solutions constitute one element of such a concept. For more information about industrial security, please visit https://www.siemens.com/industrialsecurity .	Um Anlagen, Systeme, Maschinen und Netzwerke gegen Cyber-Bedrohungen zu sichern, ist es erforderlich, ein ganzheitliches Industrial Security-Konzept zu implementieren (und kontinuierlich aufrechtzuerhalten), das dem aktuellen Stand der Technik entspricht. Die Produkte und Lösungen von Siemens formen nur einen Bestandteil eines solchen Konzepts. Weitergehende Informationen über Industrial Security finden Sie unter https://www.siemens.com/industrialsecurity .
FR <i>Note relative à la sécurité</i>	ES <i>Información de seguridad</i>
Pour garantir la sécurité des installations, systèmes, machines et réseaux contre les cybermenaces, il est nécessaire de mettre en œuvre - et de maintenir en permanence - un concept de sécurité industrielle global et de pointe. Les produits et solutions de Siemens constituent une partie de ce concept. Pour plus d'informations sur la sécurité industrielle, rendez-vous sur https://www.siemens.com/industrialsecurity .	Para proteger las instalaciones, los sistemas, las máquinas y las redes de amenazas cibernéticas, es necesario implementar - y mantener continuamente - un concepto de seguridad industrial integral conforme al estado del arte. Los productos y las soluciones de Siemens constituyen una parte de este concepto. Para obtener mayor información sobre seguridad industrial, por favor visite https://www.siemens.com/industrialsecurity .
IT <i>Avvertenze di sicurezza</i>	PT <i>Informação de Segurança</i>
Al fine di proteggere impianti, sistemi, macchine e reti da minacce cibernetiche, è necessario implementare - e mantenere continuamente - un concetto di Industrial Security globale ed all'avanguardia. I prodotti e le soluzioni Siemens costituiscono soltanto una componente imprescindibile di questo concetto. Ulteriori informazioni inerenti Industrial Security sono disponibili al sito https://www.siemens.com/industrialsecurity .	A fim de proteger instalações, sistemas, máquinas e redes contra ameaças cibernéticas, é necessário implementar - e manter continuamente - um conceito de segurança industrial holístico de acordo com a tecnologia mais avançada. Os produtos e soluções da Siemens são uma parte desse conceito. Para mais informações sobre segurança industrial, por favor visite https://www.siemens.com/industrialsecurity .
PY <i>Информация о безопасности</i>	中 <i>安全性信息</i>
Для защиты производственных комплексов, систем, машинного оборудования и сетей от киберугроз необходимо внедрение и постоянная поддержка комплексной высокотехнологичной модели промышленной безопасности. Продукты и решения Siemens являются только одним из компонентов такой модели. Для получения дополнительных сведений о промышленной безопасности см. https://www.siemens.com/industrialsecurity .	为了防止工厂、系统、机器和网络受到网络攻击，需要实施并持续维护先进且全面的工业信息安全保护机制。Siemens 的产品和解决方案构成此类概念的其中一个要素。更多有关工业信息安全的信息，请访问 https://www.siemens.com/industrialsecurity 。

EN License Information	The products contains third-party software. For further information, please refer to https://sie.ag/3ug1xFV
DE Lizenzinformationen	Das Produkt enthält Fremdsoftware. Weitere Informationen hierzu finden Sie unter https://sie.ag/3ug1xFV
FR Informations de licence	Le produit comporte des logiciels tiers. Plus d'informations : https://sie.ag/3ug1xFV
ES Información de licencia	El producto contiene software de terceros. Encontrará más información al respecto en https://sie.ag/3ug1xFV
IT Informazioni sulla licenza	Il prodotto contiene software di terze parti. Per ulteriori informazioni, vedere https://sie.ag/3ug1xFV
PT Informações da licença	O produto contém software de terceiros. Para mais informações veja https://sie.ag/3ug1xFV
TR Lisans bilgileri	Bu ürün, üçüncü taraf yazılım içerir. Daha fazla bilgiyi şu adreste bulabilirsiniz: https://sie.ag/3ug1xFV
PY Информация о лицензии	Продукт содержит программное обеспечение сторонних производителей. Для получения дополнительной информации см. https://sie.ag/3ug1xFV
PL Informacje dotyczące licencji	Produkt zawiera oprogramowanie obcych podmiotów. Więcej informacji na ten temat pod adresem https://sie.ag/3ug1xFV
中 许可证信息	该产品包含第三方软件。更多信息请访问 https://sie.ag/3ug1xFV



<https://sie.ag/3ug1xFV>

EN	NOTICE
<p>These instructions do not purport to cover all details or variations in equipment, or to provide for every possible contingency in connection with installation, operation, or maintenance. Should additional information be desired, please contact the local Siemens sales office. The contents of this instruction manual shall not become part of or modify any prior or existing agreement, commitment, or relationship. The sales contract contains the entire obligation of Siemens. The warranty contained in the contract between the parties is the sole warranty of Siemens. Any statements contained herein do not create new warranties or modify the existing warranty.</p> <p>Trademarks - Unless otherwise noted, all names identified by ® are registered trademarks of Siemens AG or Siemens Industry, Inc. The remaining trademarks in this publication may be trademarks whose use by third parties for their own purposes could violate the rights of the owner.</p>	