

# SIEMENS

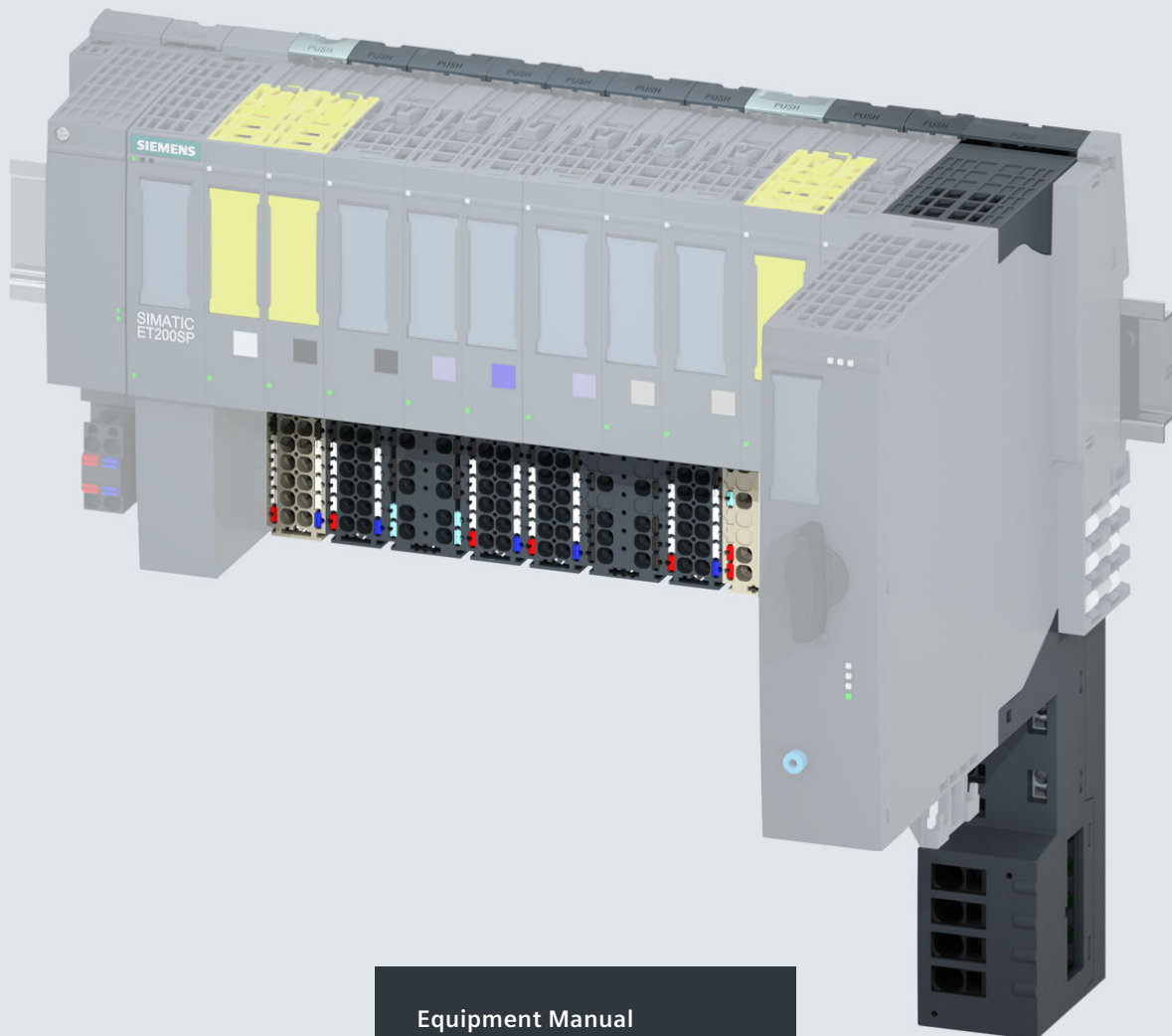

Equipment Manual

# SIMATIC

## ET 200SP

BaseUnit (6ES7193-6BP.../3RK1908-0AP00...)

Edition

04/2022

[support.industry.siemens.com](https://support.industry.siemens.com)

# SIEMENS

SIMATIC

ET 200SP  
BaseUnits  
(6ES7193-6BP...  
/3RK1908-0AP00...)



Equipment Manual

ET 200SP Documentation Guide	1
New properties	2
Product overview	3
BaseUnits for I/O modules	4
BaseUnits for motor starters	5
Potential distributor modules	6
Dimension drawings of I/O modules	A
Dimension drawings of motor starters	B
Dimension drawings of the potential distributor modules	C

## Legal information

### Warning notice system

This manual contains notices you have to observe in order to ensure your personal safety, as well as to prevent damage to property. The notices referring to your personal safety are highlighted in the manual by a safety alert symbol, notices referring only to property damage have no safety alert symbol. These notices shown below are graded according to the degree of danger.

 <b>DANGER</b>
indicates that death or severe personal injury <b>will</b> result if proper precautions are not taken.
 <b>WARNING</b>
indicates that death or severe personal injury <b>may</b> result if proper precautions are not taken.
 <b>CAUTION</b>
indicates that minor personal injury can result if proper precautions are not taken.
<b>NOTICE</b>
indicates that property damage can result if proper precautions are not taken.

If more than one degree of danger is present, the warning notice representing the highest degree of danger will be used. A notice warning of injury to persons with a safety alert symbol may also include a warning relating to property damage.

### Qualified Personnel

The product/system described in this documentation may be operated only by **personnel qualified** for the specific task in accordance with the relevant documentation, in particular its warning notices and safety instructions. Qualified personnel are those who, based on their training and experience, are capable of identifying risks and avoiding potential hazards when working with these products/systems.

### Proper use of Siemens products

Note the following:

 <b>WARNING</b>
Siemens products may only be used for the applications described in the catalog and in the relevant technical documentation. If products and components from other manufacturers are used, these must be recommended or approved by Siemens. Proper transport, storage, installation, assembly, commissioning, operation and maintenance are required to ensure that the products operate safely and without any problems. The permissible ambient conditions must be complied with. The information in the relevant documentation must be observed.

### Trademarks

All names identified by ® are registered trademarks of Siemens AG. The remaining trademarks in this publication may be trademarks whose use by third parties for their own purposes could violate the rights of the owner.

### Disclaimer of Liability

We have reviewed the contents of this publication to ensure consistency with the hardware and software described. Since variance cannot be precluded entirely, we cannot guarantee full consistency. However, the information in this publication is reviewed regularly and any necessary corrections are included in subsequent editions.

# Preface

## Purpose of the documentation

This manual supplements the system manual ET 200SP distributed I/O system (<http://support.automation.siemens.com/WW/view/en/58649293>). Functions affecting the system in general are described there.

The information provided in this manual and in the system/function manuals supports you in commissioning the system.

## Conventions

Please also observe notes marked as follows:

---

### NOTE

A note contains important information on the product described in the documentation, on the handling of the product and on the section of the documentation to which particular attention should be paid.

---

## Changes compared to the previous version

In contrast to the previous version, the chapters "BaseUnits for motor starters" and "Dimension drawings for motor starters" have been added to this manual.

## Recycling and disposal

For ecologically sustainable recycling and disposal of your old device, contact a certificated disposal service for electronic scrap and dispose of the device in accordance with the regulations in your country.

## Security information

Siemens provides products and solutions with industrial security functions that support the secure operation of plants, systems, machines and networks.

In order to protect plants, systems, machines and networks against cyber threats, it is necessary to implement – and continuously maintain – a holistic, state-of-the-art industrial security concept. Siemens' products and solutions constitute one element of such a concept. Customers are responsible for preventing unauthorized access to their plants, systems, machines and networks. Such systems, machines and components should only be connected to an enterprise network or the internet if and to the extent such a connection is necessary

and only when appropriate security measures (e.g. firewalls and/or network segmentation) are in place.

For additional information on industrial security measures that may be implemented, please visit (<https://www.siemens.com/industrialsecurity>).

Siemens' products and solutions undergo continuous development to make them more secure. Siemens strongly recommends that product updates are applied as soon as they are available and that the latest product versions are used. Use of product versions that are no longer supported, and failure to apply the latest updates may increase customers' exposure to cyber threats.

To stay informed about product updates, subscribe to the Siemens Industrial Security RSS Feed visit (<https://www.siemens.com/cert>).

# Table of contents

<b>1</b>	<b>ET 200SP Documentation Guide.....</b>	<b>10</b>
1.1	ET 200SP Documentation Guide.....	10
1.2	SIMATIC Technical Documentation.....	11
1.3	Tool support.....	12
1.3.1	Tool support.....	12
<b>2</b>	<b>New properties.....</b>	<b>15</b>
<b>3</b>	<b>Product overview.....</b>	<b>17</b>
<b>4</b>	<b>BaseUnits for I/O modules.....</b>	<b>22</b>
4.1	Product description.....	22
4.1.1	Introduction.....	22
4.2	BU type A0, light-colored version with AUX terminals.....	22
4.2.1	Product overview.....	22
4.2.2	Connecting up.....	24
4.2.3	Technical specifications.....	25
4.3	BU type A0, light-colored version without AUX terminals.....	26
4.3.1	Product overview.....	26
4.3.2	Connection.....	28
4.3.3	Technical specifications.....	28
4.4	BU type A0, dark-colored version, with AUX terminals.....	30
4.4.1	Product overview.....	30
4.4.2	Connection.....	32
4.4.3	Technical specifications.....	33
4.5	BU type A0, dark-colored version, without AUX terminals .....	34
4.5.1	Product overview.....	34
4.5.2	Connection.....	36
4.5.3	Technical specifications.....	36
4.6	BU type A1, light-colored version, with additional terminals.....	38
4.6.1	Product overview.....	38
4.6.2	Connection.....	40
4.6.3	Technical specifications.....	41
4.7	BU type A1, light-colored version, without additional terminals.....	43
4.7.1	Product overview.....	43
4.7.2	Connection.....	44
4.7.3	Technical specifications.....	45
4.8	BU type A1, dark-colored version, with additional terminals.....	46
4.8.1	Product overview.....	46
4.8.2	Connection.....	48
4.8.3	Technical specifications.....	49

4.9	BU type A1, dark-colored version, without additional terminals.....	50
4.9.1	Product overview.....	50
4.9.2	Connection.....	52
4.9.3	Technical specifications.....	52
4.10	BU type B0, dark-colored version, with AUX terminals, supply over P1, P2 busbar.....	54
4.10.1	Product overview.....	54
4.10.2	Connecting.....	55
4.10.3	Technical specifications.....	56
4.11	BU type B1, dark-colored version, without AUX terminals, supply over supply terminals....	58
4.11.1	Product overview.....	58
4.11.2	Connecting up.....	59
4.11.3	Technical specifications.....	60
4.12	BU type C0, light-colored version, with AUX terminals, supply over supply terminals.....	62
4.12.1	Product overview.....	62
4.12.2	Connecting.....	63
4.12.3	Technical specifications.....	64
4.13	BU type C1, dark-colored version, with AUX terminals, supply over P1, P2 busbar.....	66
4.13.1	Product overview.....	66
4.13.2	Connecting.....	67
4.13.3	Technical specifications.....	68
4.14	BU type D0, dark-colored version, without AUX terminals, supply over supply terminals....	70
4.14.1	Product overview.....	70
4.14.2	Connecting.....	71
4.14.3	Technical specifications.....	72
4.15	BU type F0, dark-colored version, with AUX terminals, supply over supply terminals.....	74
4.15.1	Product overview.....	74
4.15.2	Connecting up.....	75
4.15.3	Technical specifications.....	76
4.16	BU type U0, light-colored version without AUX terminals.....	77
4.16.1	Product overview.....	77
4.16.2	Connection.....	79
4.16.3	Technical specifications.....	79
4.17	BU type U0, dark-colored version, without AUX terminals.....	81
4.17.1	Product overview.....	81
4.17.2	Connection.....	83
4.17.3	Technical specifications.....	83
<b>5</b>	<b>BaseUnits for motor starters.....</b>	<b>86</b>
5.1	Introduction.....	86
5.2	Safety-related shutdown.....	86
5.3	BU30-MS1 - BaseUnit with 24 V DC and 500 V AC infeed.....	87
5.3.1	Product overview.....	87
5.3.2	Connection.....	88
5.3.3	Technical specifications.....	89

5.4	BU30-MS2 - BaseUnit with 500 V AC infeed.....	90
5.4.1	Product overview.....	90
5.4.2	Connection.....	92
5.4.3	Technical specifications.....	93
5.5	BU30-MS3 - BaseUnit with 24 V DC infeed.....	93
5.5.1	Product overview.....	93
5.5.2	Connection.....	95
5.5.3	Technical specifications.....	96
5.6	BU30-MS4 - BaseUnit without infeed.....	96
5.6.1	Product overview.....	96
5.6.2	Connection.....	98
5.6.3	Technical specifications.....	98
5.7	BU30-MS5 BaseUnit with 500 V AC infeed and single F-DI.....	99
5.7.1	Product overview.....	99
5.7.2	Connection.....	101
5.7.3	Technical specifications.....	102
5.8	BU30-MS6 Base Unit without infeed and with single F-DI.....	103
5.8.1	Product overview.....	103
5.8.2	Connection.....	104
5.8.3	Technical specifications.....	105
5.9	BU30-MS7 BaseUnit with F-DI and 500 V AC infeed.....	106
5.9.1	Product overview.....	106
5.9.2	Connecting up.....	108
5.9.3	Technical specifications.....	109
5.10	BU30-MS8 BaseUnit with 500 V AC infeed and F-DI routing.....	110
5.10.1	Product overview.....	110
5.10.2	Connection.....	112
5.10.3	Technical specifications.....	113
5.11	BU30-MS9 BaseUnit with F-DI routing.....	114
5.11.1	Product overview.....	114
5.11.2	Connection.....	115
5.11.3	Technical specifications.....	116
5.12	BU30-MS10 BaseUnit with F-DI infeed.....	116
5.12.1	Product overview.....	116
5.12.2	Connection.....	118
5.12.3	Technical specifications.....	119
<b>6</b>	<b>Potential distributor modules.....</b>	<b>120</b>
6.1	Introduction.....	120
6.2	PotDis-BU type P1, light-colored version.....	121
6.2.1	Short designation.....	121
6.2.2	Product overview.....	121
6.2.3	Connecting.....	122
6.2.4	Technical specifications.....	123
6.3	PotDis-BU type P1, dark-colored version.....	124



---

6.3.1	Product overview.....	124
6.3.2	Connecting.....	125
6.3.3	Technical specifications.....	126
6.4	PotDis-BU type P2, light-colored version.....	127
6.4.1	Short designation.....	127
6.4.2	Product overview.....	128
6.4.3	Connecting.....	129
6.4.4	Technical specifications.....	130
6.5	PotDis-BU type P2, dark-colored version.....	131
6.5.1	Short designation.....	131
6.5.2	Product overview.....	131
6.5.3	Connecting.....	132
6.5.4	Technical specifications.....	133
6.6	PotDis-TB.....	134
6.6.1	Product overview.....	134
6.6.2	Connecting.....	136
6.6.3	Technical specifications.....	137
<b>A</b>	<b>Dimension drawings of I/O modules.....</b>	<b>142</b>
<b>B</b>	<b>Dimension drawings of motor starters.....</b>	<b>145</b>
<b>C</b>	<b>Dimension drawings of the potential distributor modules.....</b>	<b>146</b>
	<b>Index.....</b>	<b>147</b>

# ET 200SP Documentation Guide

## 1.1 ET 200SP Documentation Guide



The documentation for the SIMATIC ET 200SP distributed I/O system is arranged into three areas.

This arrangement enables you to access the specific content you require.

You can download the documentation free of charge from the Internet

(<https://support.industry.siemens.com/cs/ww/en/view/109742709>).

### Basic information



The System Manual describes in detail the configuration, installation, wiring and commissioning of the SIMATIC ET 200SP distributed I/O system.

The STEP 7 online help supports you in the configuration and programming.

Examples:

- ET 200SP System Manual
- System Manual ET 200SP HA/ET 200SP modules for devices used in a hazardous area
- Online help TIA Portal

### Device information



Equipment manuals contain a compact description of the module-specific information, such as properties, wiring diagrams, characteristics and technical specifications.

Examples:

- Equipment Manuals CPUs
- Equipment Manuals Interface Modules
- Equipment Manuals Digital Modules
- Equipment Manuals Analog Modules
- Equipment Manuals Motor Starter
- BaseUnits Equipment Manuals
- Equipment Manual Server Module
- Equipment Manuals Communications Modules
- Equipment Manuals Technology Modules

## General information



The function manuals contain detailed descriptions on general topics relating to the SIMATIC ET 200SP distributed I/O system.

Examples:

- Function Manual ET 200AL/ET 200SP Mixed Configuration
- Function Manual Diagnostics
- Function Manual Communication
- PROFINET Function Manual
- PROFIBUS Function Manual
- Function Manual Designing Interference-free Controllers
- MultiFieldbus Function Manual

## Product Information

Changes and supplements to the manuals are documented in a Product Information. The Product Information takes precedence over the device and system manuals.

You can find the latest Product Information on the ET 200SP distributed I/O system on the Internet. (<https://support.industry.siemens.com/cs/de/en/view/73021864>)

## Manual Collection ET 200SP

The Manual Collection contains the complete documentation on the SIMATIC ET 200SP distributed I/O system gathered together in one file.

You can find the Manual Collection on the Internet.

(<https://support.industry.siemens.com/cs/ww/en/view/84133942>)

## 1.2 SIMATIC Technical Documentation

Additional SIMATIC documents will complete your information. You can find these documents and their use at the following links and QR codes.

The Industry Online Support gives you the option to get information on all topics. Application examples support you in solving your automation tasks.

### Overview of the SIMATIC Technical Documentation

Here you will find an overview of the SIMATIC documentation available in SIOS:



Industry Online Support International

(<https://support.industry.siemens.com/cs/ww/en/view/109742705>)

Watch this short video to find out where you can find the overview directly in SIOS and how to use SIOS on your mobile device:



Quick introduction to the technical documentation of automation products per video (<https://support.industry.siemens.com/cs/us/en/view/109780491>)



YouTube video: Siemens Automation Products - Technical Documentation at a Glance (<https://youtu.be/TwLSxxRQQsA>)

## mySupport

With "mySupport" you can get the most out of your Industry Online Support.

<b>Registration</b>	You must register once to use the full functionality of "mySupport". After registration, you can create filters, favorites and tabs in your personal workspace.
<b>Support requests</b>	Your data is already filled out in support requests, and you can get an overview of your current requests at any time.
<b>Documentation</b>	In the Documentation area you can build your personal library.
<b>Favorites</b>	You can use the "Add to mySupport favorites" to flag especially interesting or frequently needed content. Under "Favorites", you will find a list of your flagged entries.
<b>Recently viewed articles</b>	The most recently viewed pages in mySupport are available under "Recently viewed articles".
<b>CAX data</b>	The CAX data area gives you access to the latest product data for your CAX or CAE system. You configure your own download package with a few clicks: <ul style="list-style-type: none"> <li>• Product images, 2D dimension drawings, 3D models, internal circuit diagrams, EPLAN macro files</li> <li>• Manuals, characteristics, operating manuals, certificates</li> <li>• Product master data</li> </ul>

You can find "mySupport" on the Internet. (<https://support.industry.siemens.com/My/ww/en>)

## Application examples

The application examples support you with various tools and examples for solving your automation tasks. Solutions are shown in interplay with multiple components in the system - separated from the focus on individual products.

You can find the application examples on the Internet.

(<https://support.industry.siemens.com/cs/ww/en/ps/ae>)

## 1.3 Tool support

### 1.3.1 Tool support

The tools described below support you in all steps: from planning, over commissioning, all the way to analysis of your system.

#### TIA Selection Tool

The TIA Selection Tool tool supports you in the selection, configuration, and ordering of devices for Totally Integrated Automation (TIA).

As successor of the SIMATIC Selection Tools, it assembles the configuration editors for automation technology already familiar into a single tool.

With the TIA Selection Tool, you can generate a complete order list from your product selection or product configuration.

You can find the TIA Selection Tool on the Internet.

(<https://support.industry.siemens.com/cs/ww/en/view/109767888>)

#### SIMATIC Automation Tool

You can use the SIMATIC Automation Tool to perform commissioning and maintenance activities on various SIMATIC S7 stations as bulk operations independent of TIA Portal.

The SIMATIC Automation Tool offers a wide range of functions:

- Scanning of a PROFINET/Ethernet system network and identification of all connected CPUs
- Assignment of addresses (IP, subnet, Gateway) and device name (PROFINET device) to a CPU
- Transfer of the date and the programming device/PC time converted to UTC time to the module
- Program download to CPU
- RUN/STOP mode switchover
- CPU localization through LED flashing
- Reading out of CPU error information
- Reading the CPU diagnostic buffer
- Reset to factory settings
- Firmware update of the CPU and connected modules

You can find the SIMATIC Automation Tool on the Internet.

(<https://support.industry.siemens.com/cs/ww/en/view/98161300>)

## PRONETA

SIEMENS PRONETA (PROFINET network analysis) is a commissioning and diagnostic tool for PROFINET networks. PRONETA Basic has two core functions:

- The "Network analysis" offers a quick overview of the PROFINET topology. It is possible to make simple parameter changes (for example, to the names and IP addresses of the devices). In addition, a quick and convenient comparison of the real configuration with a reference system is also possible.
- The "IO test" is a simple and rapid test of the wiring and the module configuration of a plant, including documentation of the test results.

You can find SIEMENS PRONETA Basic on the Internet:

(<https://support.industry.siemens.com/cs/ww/en/view/67460624>)

SIEMENS PRONETA Professional is a licensed product that offers you additional functions. It offers you simple asset management in PROFINET networks and supports operators of automation systems in automatic data collection/acquisition of the components used through various functions:

- The user interface (API) offers an access point to the automation cell to automate the scan functions using MQTT or a command line.
- With PROFIenergy diagnostics, you can quickly detect the current pause mode or the readiness for operation of devices that support PROFIenergy and change these as needed.
- The data record wizard supports PROFINET developers in reading and writing acyclic PROFINET data records quickly and easily without PLC and engineering.

You can find SIEMENS PRONETA Professional on the Internet:

(<https://www.siemens.com/proneta-professional>)

## SINETPLAN

SINETPLAN, the Siemens Network Planner, supports you in planning automation systems and networks based on PROFINET. The tool facilitates professional and predictive dimensioning of your PROFINET installation as early as in the planning stage. In addition, SINETPLAN supports you during network optimization and helps you to exploit network resources optimally and to plan reserves. This helps to prevent problems in commissioning or failures during productive operation even in advance of a planned operation. This increases the availability of the production plant and helps improve operational safety.

### 1.3 Tool support

The advantages at a glance

- Network optimization thanks to port-specific calculation of the network load
- Increased production availability thanks to online scan and verification of existing systems
- Transparency before commissioning through importing and simulation of existing STEP 7 projects
- Efficiency through securing existing investments in the long term and the optimal use of resources

You can find SINETPLAN on the Internet

(<https://new.siemens.com/global/en/products/automation/industrial-communication/profinet/sinetplan.html>).

## New properties

### What's new in the ET 200SP System Manual, Edition 04/2022 compared to Edition 09/2019?

What's new?		What are the customer benefits?	Where can I find information?
New contents	New shield terminal for connecting cable shields	The new stacked shield terminal provides extended space for clamping thanks to two clamping positions. In addition, a supporting element absorbs torsional and bending forces.	Section Dimension drawings of I/O modules <a href="#">(Page 142)</a>

### What's new in the BaseUnits equipment manual, edition 09/2019, compared to edition 02/2018?

What's new?		What are the customer benefits?	Where can I find the information?
New contents	BaseUnits BU30-MS7, BU30-MS8, BU30-MS9 and BU30-MS10 for fail-safe motor starters	A simple, wire-saving group shutdown for fail-safe motor starters. In contrast to the earlier solution (BU30-MS5 and BU30-MS6), the fail-safe signal only has to be wired to the first motor starter. The fail-safe signal is internally routed via the BaseUnits.	Section BU30-MS7 BaseUnit with F-DI and 500 V AC infeed <a href="#">(Page 106)</a> Section BU30-MS8 BaseUnit with 500 V AC infeed and F-DI routing <a href="#">(Page 110)</a> Section BU30-MS9 BaseUnit with F-DI routing <a href="#">(Page 113)</a> Section BU30-MS10 BaseUnit with F-DI infeed <a href="#">(Page 116)</a>

### What's new in the BaseUnits manual, edition 02/2018, compared to edition 12/2016?

What's new?		What are the customer benefits?	Where can I find information?
New contents	Potential distributor modules	A system-integrated potential distribution can be implemented via the PotDis modules. One application is, for example, the design of digital input modules with 16 channels and three-wire connection. You use the potential distributor modules to reserve the unused signal cables of antivalent sensors. Another application is the supply of potentials for supply of external components.	Section Potential distributor modules <a href="#">(Page 120)</a>
	BaseUnit type U0 Can be used for all I/O modules whose article number ends in U0	Light-colored version: BU20-P16+A0+2D Per slot, up to 16 process terminals to the module are supplied with max. 230 V per terminal. <ul style="list-style-type: none"> <li>• 2 supply terminals on integrated self-assembling voltage buses P1/P2, max. 230 V AC/10 A</li> <li>• Separation of voltage buses P1/P2 and AUX from the adjacent module on the left</li> </ul>	Section BU20-P16+A0+2D <a href="#">(Page 77)</a>

What's new?		What are the customer benefits?	Where can I find information?
New contents	BaseUnit type U0 Can be used for all I/O modules whose article number ends in U0	Dark-colored version: BU20-P16+A0+2B Per slot, up to 16 process terminals to the module are supplied with max. 230 V per terminal. <ul style="list-style-type: none"> <li>2 terminals for external supply/forwarding from integrated self-assembling voltage buses P1/P2</li> <li>Bridging voltage buses P1/P2 and AUX to the adjacent module on the left</li> </ul>	Section BU20-P16+A0+2B ( <a href="#">Page 81</a> )

### Terminal labeling of the PotDis-TB

New specification offers the following advantages:

- Unique terminal numbering per slot, even if the same reference identifier is used for the PotDis-BU and the PotDis-TB of a slot.
- Best possible readability
- Shortest possible designation to keep the work for conductor labeling as low as possible
- Compliant with ECAD rules
- Consistent with the previous ET 200SP logic
- You can continue using the color-coded label CC00

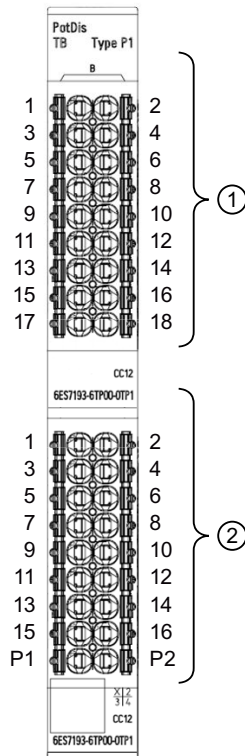

- ① **Terminal labeling of the PotDis-TB** B1 to B18. To save space, the preceding character "B" is printed once at the top and must not be covered by the color-code labels.
- ② **Terminal labeling of the PotDis-BU** 1 to 16, the infeed terminals P1 and P2.



## Product overview

### General properties of the BaseUnits

The ET 200SP distributed I/O system includes various BaseUnits. You use the BaseUnit to specify the following, for example:

- Process connection
- Plug-in I/O module/motor starter
- Infeed of supply voltage specified

You can recognize the properties of the BaseUnits from their short description:

Table 3-1 Properties of the BaseUnits

Short description BU15-P16+A10+2D/T (example)			BaseUnit properties
Name/module width	BU	15	BaseUnit with width of 15 mm
		20	BaseUnit with width of 20 mm
		30	BaseUnit with width of 30 mm
Process connection	P	4	<ul style="list-style-type: none"> <li>• Connection method: Push-in terminal</li> <li>• Number of terminals to the I/O module: 4</li> </ul>
		8	<ul style="list-style-type: none"> <li>• Connection method: Push-in terminal</li> <li>• Number of terminals to the I/O module: 8</li> </ul>
		16	<ul style="list-style-type: none"> <li>• Connection method: Push-in terminal</li> <li>• Number of terminals to the I/O module: 16</li> </ul>
Connection to the AUX busbar	A	0	No connection to the AUX busbar
		10	n = number of AUX terminals, e.g. 10
Self-assembling voltage buses	2		2 push-in terminals for supplying or tapping the supply voltage via the self-assembling voltage buses P1, P2 (see D, B)
	12		<ul style="list-style-type: none"> <li>• 2 push-in terminals for supplying or tapping the supply voltage via the self-assembling voltage buses P1, P2 (see D, B)</li> <li>• 2x5 push-in additional terminals (1 B to 5 B, 1 C to 5 C). For connecting further potential up to a maximum supply current of 24 V DC/10 A</li> </ul>
	0		No terminals with access to the self-assembling voltage buses P1, P2
		B	<ul style="list-style-type: none"> <li>• Looping through the potential group</li> <li>• Tapping the supply voltage for external components or looping through with a maximum total current of 10 A per potential group</li> </ul>
		D	<ul style="list-style-type: none"> <li>• Opening a new potential group</li> <li>• Feeding in of supply voltage up to a maximum supply current of 10 A</li> </ul>
Additional functions	T		Integrated temperature sensor to compensate the reference junction temperature for thermocouples

## Properties of the BaseUnits for motor starters

The following table lists the properties of the individual BaseUnits for motor starters:

BaseUnit	Properties
BU30-MS1	<ul style="list-style-type: none"> <li>• Push-in terminals for opening a new potential group (24 V DC).</li> <li>• Feeding in of supply voltage up to a maximum supply current of 7 A DC.</li> <li>• Opening a new supply voltage potential group (500 V AC)</li> <li>• Feeding in of supply voltage up to a maximum supply current of 32 A AC.</li> </ul>
BU30-MS2	<ul style="list-style-type: none"> <li>• Further conduction of the potential group (24 V DC)</li> <li>• Push-in terminals for opening a new supply voltage potential group (500 V AC)</li> <li>• Infeed of supply voltage up to a maximum supply current up to 32 A AC.</li> </ul>
BU30-MS3	<ul style="list-style-type: none"> <li>• Push-in terminals for opening a new potential group (24 V DC)</li> <li>• Infeed of the supply voltage L+ up to an infeed current of 7 A DC</li> <li>• Further conduction of the supply voltage potential group (500 V AC)</li> </ul>
BU30-MS4	<ul style="list-style-type: none"> <li>• Further conduction of the supply voltage potential group (500 V AC)</li> <li>• Further conduction of the potential group (24 V DC)</li> </ul>
BU30-MS5	<ul style="list-style-type: none"> <li>• Further conduction of the potential group (24 V DC)</li> <li>• Push-in terminals for opening a new supply voltage potential group (500 V AC)</li> <li>• Infeed of supply voltage up to a maximum supply current of 32 A AC</li> <li>• A fail-safe digital input</li> </ul>
BU30-MS6	<ul style="list-style-type: none"> <li>• Further conduction of the potential group (24 V DC)</li> <li>• Further conduction of the supply voltage potential group (500 V AC)</li> <li>• A fail-safe digital input</li> </ul>
BU30-MS7	<ul style="list-style-type: none"> <li>• Further conduction of the potential group (24 V DC)</li> <li>• Infeed F-DI busbar</li> <li>• Push-in terminals for opening a new supply voltage potential group (500 V AC)</li> <li>• Infeed of supply voltage up to a maximum supply current of up to AC 32 A.</li> </ul>
BU30-MS8	<ul style="list-style-type: none"> <li>• Further conduction of the potential group (24 V DC)</li> <li>• Further conduction of the F-DI busbar</li> <li>• Push-in terminals for opening a new supply voltage potential group (500 V AC)</li> <li>• Infeed of supply voltage up to a maximum supply current up to 32 A AC.</li> </ul>
BU30-MS9	<ul style="list-style-type: none"> <li>• Further conduction of the potential group (24 V DC)</li> <li>• Further conduction of the F-DI busbar</li> <li>• Further conduction of the supply voltage potential group (500 V AC)</li> </ul>
BU30-MS10	<ul style="list-style-type: none"> <li>• Further conduction of the potential group (24 V DC)</li> <li>• Infeed F-DI busbar</li> <li>• Further conduction of the supply voltage potential group (500 V AC)</li> </ul>

## Properties of the potential distributor modules

The following table shows the properties of the individual potential distributor modules:

Table 3-2 PotDis-BaseUnits properties

Short description PotDis-BU-P1/D-R (example)		PotDis-BaseUnit properties
Designation	PotDis-BU	PotDis-BaseUnit
Process connection (24 V DC / 10 A)	P1	Terminals for supplying or tapping the supply voltage with connection to the voltage bus P1 (see D, B)
	P2	Terminals for supplying or tapping the supply voltage with connection to the voltage bus P2 (see D, B)
Self-assembling voltage buses	D	<ul style="list-style-type: none"> <li>Opening a new PotDis potential group</li> <li>Feeding in of supply voltage up to a maximum supply current up to 10 A</li> <li>Tapping the supply voltage for external components or looping with a maximum total current of 10 A per potential group</li> </ul>
	B	<ul style="list-style-type: none"> <li>Further conduction of the potential group</li> <li>Tapping the supply voltage for external components or looping with a maximum total current of 10 A per potential group</li> </ul>
Color coding of the spring releases	R	Connection to the internal voltage bus P1 Red spring release
	B	Connection to the internal voltage bus P2 Blue spring release

## Properties of the terminal blocks PotDis-TB

The following table shows the properties of the individual terminal blocks:

Table 3-3 Properties of the PotDis-Terminalblocks

Short description PotDis-TB-P1-R (example)		PotDis-Terminalblock properties
Designation	PotDis-TB	PotDis terminal block
Process connection (24 V DC / 10 A)	P1	<ul style="list-style-type: none"> <li>Connection to the voltage bus P1</li> <li>Terminals for picking off the rated supply voltage 24 V DC with max. 10 A of the same voltage level</li> </ul>
	P2	<ul style="list-style-type: none"> <li>Connection to the voltage bus P2</li> <li>Terminals for picking off the rated supply voltage 24 V DC with max. 10 A of the same voltage level</li> </ul>
	n.c.	<ul style="list-style-type: none"> <li>No connection to the P1, P2 or AUX bus</li> <li>Terminals can be used freely up to 230 V AC with max. 10 A</li> </ul>
	BR	<ul style="list-style-type: none"> <li>No connection to the P1, P2 or AUX bus</li> <li>Terminals for protective conductor connection or voltage bus (internal connected) freely usable up to 230 V AC with max. 10 A</li> </ul>

Short description PotDis-TB-P1-R (example)	PotDis-Terminalblock properties	
Color coding of the spring releases	R	Red spring release
	B	Blue spring release
	W	White spring release
	G	Gray spring release

### Selecting, installing and connecting BaseUnits

You can find additional information in the system manual ET 200SP Distributed I/O System (<http://support.automation.siemens.com/WW/view/en/58649293>).

<p><b>⚠ WARNING</b></p> <p><b>Personal injury or damage to equipment is possible.</b></p> <p>Connecting a rated supply voltage to the BaseUnit higher than the one given in the technical specifications may lead to dangerous situations in your plant or cause defects in ET 200SP components.</p> <p>Therefore, only connect the rated supply voltage given in the technical specifications to the BaseUnit.</p> <p>The connected rated supply voltage must correspond to the rated supply voltage of the I/O modules in the potential group.</p> <p>When mains voltage is connected to the BaseUnit, ensure that all other supply voltages on this BaseUnit use the same phase as the mains.</p>
--

The Totally Integrated Automation Selection Tool (TIA Selection Tool) (<http://w3.siemens.com/mcmts/topics/de/simatic/tia-selection-tool>) supports you in selecting, configuring and ordering the ET 200SP modules. The free TIA Selection Tool is available on the Internet (<http://support.automation.siemens.com/WW/view/en/58649293>).

<p><b>⚠ WARNING</b></p> <p><b>Hazardous Voltage (when using ET 200SP motor starters) Can Cause Death, Serious Injury, or Property Damage.</b></p> <p>Proper use of hardware products</p> <p>This equipment is only allowed to be used for the applications described in the catalog and in the technical description, and only in conjunction with non-Siemens equipment and components recommended by Siemens.</p> <p>Correct transport, storage, installation and assembly, as well as careful operation and maintenance, are required to ensure that the product operates safely and without faults.</p> <p>EU note: Start-up/commissioning is absolutely prohibited until it has been ensured that the machine in which the component described here is to be installed fulfills the regulations/specifications of Machinery Directive 2006/42/EC.</p>
--

**⚠ WARNING****Hazardous Voltage (when using ET 200SP motor starters)  
Can Cause Death, Serious Injury, or Property Damage.**

Please take note of our latest information.

Systems with safety-related characteristics are subject to special operational safety requirements on the part of the operator. The supplier is also obliged to comply with special product monitoring measures. For this reason, we publish a special newsletter containing information on product developments and features that are (or could be) relevant to operation of safety-related systems. You need to subscribe to the corresponding newsletter to ensure that you always remain up-to-date and are able to make any necessary changes to your plant regarding operational safety should the need arise.

Siemens Newsletter (<http://www.industry.siemens.com/newsletter>)

Sign on to the following newsletter under "Products & Solutions":

- Control Components and System Engineering News
- Safety Integrated Newsletter

## BaseUnits for I/O modules

### 4.1 Product description

#### 4.1.1 Introduction

##### Properties of the BaseUnits

The ET 200SP distributed I/O system offers you a rugged and service-friendly design with permanent wiring over the BaseUnits (BU).

The BaseUnits provide the electrical and mechanical connection of the ET 200SP modules. A wide range of BaseUnits is available to suit individual requirements.

You can place BaseUnits at any location with the ET 200SP distributed I/O system. Take into account the specific properties of the respective BaseUnit. Thanks to the push-in connection system, you can wire the terminals without tools.

You can find additional information on using the BaseUnit in the ET 200SP System Manual (<https://support.industry.siemens.com/cs/ww/en/view/58649293>).

---

##### NOTE

All BaseUnits placed in a potential group have to match the infeed potential of the corresponding light-colored BaseUnit.

---

---

##### NOTE

The following BaseUnits with functional version < 04 can only be used in potential groups with rated voltages  $\leq 48$  V DC or 24 V AC:

- BaseUnit BU20-P12+A0+4B (6ES7193-6BP20-0BB1).
  - BaseUnit BU20-P12+A0+0B (6ES7193-6BP00-0BD0).
- 

### 4.2 BU type A0, light-colored version with AUX terminals

#### Short designation

Short designation: BU15-P16+A10+2D

#### 4.2.1 Product overview

##### Delivery options (packing unit VPE)

6ES7193-6BP20-0DA0 (VPE: 1 unit)

6ES7193-6BP20-2DA0 (VPE: 10 units)

## View

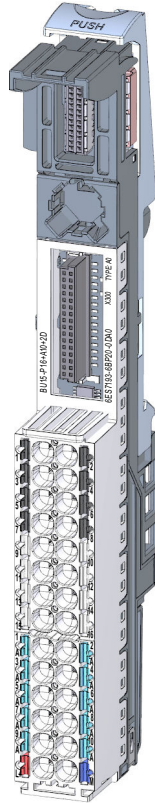

Figure 4-1 BU type A0, light-colored version with AUX terminals

## Properties

- BaseUnit suitable for all I/O modules of the BaseUnit type "A0/A1". Can be recognized by the laser inscription on the front and/or the last two digits of the article number.
  - Supply voltage (L+ terminal, ground): Max. 24 V DC/10 A
  - Current-carrying capacity per process terminal (terminal 1 to 16): Max. 2 A
- The BaseUnit opens up a new potential group. The self-assembling voltage buses P1 and P2, and the AUX busbar are interrupted to the left-hand neighboring module (BaseUnit, interface module).
- Access to the AUX busbar via terminals
- 16 terminals to the process (assignment through the I/O module)
- 10 AUX terminals for connecting a protective conductor or potential. The AUX busbar is not connected to the I/O module. Max. 24 V DC/10 A
- Connection system in the form of push-in terminals Connection cross-sections are available in the ET 200SP System Manual (<https://support.industry.siemens.com/cs/ww/en/view/58649293>).

### Maximum configuration per potential group

The number of I/O modules that can be used per potential group depends on the following factors:

1. Total power requirement of all I/O modules operated on this potential group
2. Total power requirement of all loads connected externally to this potential group

The total current calculated according to item 1. and item 2. must not exceed 10 A.

### 4.2.2 Connecting up

#### Pin assignment

Pin assignment for BaseUnit BU type A0, light-colored version with AUX terminals	
Terminal	Descriptions
1 to 16	Assignment is determined by the I/O module. You can find additional information in the I/O Module ( <a href="http://support.automation.siemens.com/WW/view/en/55679691/133300">http://support.automation.siemens.com/WW/view/en/55679691/133300</a> ) manual.
1 A, 2 A, 3 A, 4 A, 5 A, 6 A, 7 A, 8 A, 9 A, 10 A	Protective conductor connection or voltage bus freely usable up to 24 V DC with max. 10 A
L+/M	L+: Rated supply voltage 24 V DC with max. 10 A M: Ground

#### Block diagram

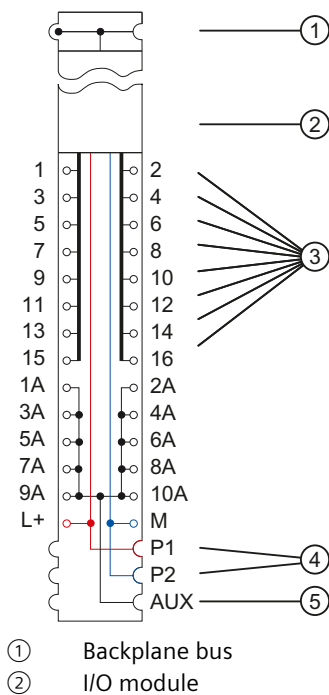



- ③ Terminals with connection to the I/O module
- ④ System-integrated, self-assembling voltage buses P1, P2 with connection to the infeed terminals, interrupted to the adjacent module on the left, form a new potential group
- ⑤ System-integrated, self-assembling AUX voltage bus with connection to the 10 AUX terminals, interrupted to the adjacent module on the left forms a new potential group

Figure 4-2 Block diagram of the BU type A0, light-colored version with AUX terminals

### 4.2.3 Technical specifications

#### Technical specifications of the BU type A0, light-colored version with AUX terminals

Article number	6ES7193-6BP20-2DA0
<b>General information</b>	
Product type designation	BU type A0
HW functional status	From FS07
<b>Supply voltage</b>	
Rated value (DC)	24 V
external protection for power supply lines	Yes; 24 V DC/10 A miniature circuit breaker with type B or C tripping characteristic
<b>Current carrying capacity</b>	
For P1 and P2 bus, max.	10 A
For AUX bus, max.	10 A
For process terminals, max.	2 A
<b>Hardware configuration</b>	
<b>Formation of potential groups</b>	
• New potential group	Yes
• Potential group continued from the left	No
<b>Potential separation</b>	
between the potential groups	Yes
<b>Isolation</b>	
Isolation tested with	707 V DC (type test)
<b>Ambient conditions</b>	
<b>Ambient temperature during operation</b>	
• horizontal installation, min.	-30 °C
• horizontal installation, max.	60 °C
• vertical installation, min.	-30 °C
• vertical installation, max.	50 °C
<b>Altitude during operation relating to sea level</b>	
• Installation altitude above sea level, max.	5 000 m; Restrictions for installation altitudes > 2 000 m, see manual
<b>Accessories</b>	
<b>Color coding labels</b>	
• for process terminals	CC00 to CC09
• for AUX terminals	CC71 to CC73

## 4.3 BU type A0, light-colored version without AUX terminals

<b>Article number</b>	<b>6ES7193-6BP20-2DA0</b>
<ul style="list-style-type: none"> <li>for add-on terminals</li> </ul>	does not exist
<b>Connection method</b>	
<b>Terminals</b>	
<ul style="list-style-type: none"> <li>Terminal type</li> </ul>	Push-in terminal
<ul style="list-style-type: none"> <li>Conductor cross-section, min.</li> </ul>	0.14 mm <sup>2</sup> ; AWG 26
<ul style="list-style-type: none"> <li>Conductor cross-section, max.</li> </ul>	2.5 mm <sup>2</sup> ; AWG 14
<ul style="list-style-type: none"> <li>Number of process terminals to I/O module</li> </ul>	16
<ul style="list-style-type: none"> <li>Number of terminals to AUX bus</li> </ul>	10
<ul style="list-style-type: none"> <li>Number of add-on terminals</li> </ul>	0
<ul style="list-style-type: none"> <li>Number of terminals with connection to P1 and P2 bus</li> </ul>	2
<b>Dimensions</b>	
Width	15 mm
Height	141 mm
Depth	35 mm
<b>Weights</b>	
Weight, approx.	50 g

## 4.3 BU type A0, light-colored version without AUX terminals

### Short designation

Short designation: BU15-P16+A0+2D

### 4.3.1 Product overview

#### Delivery options (packing unit VPE)

6ES7193-6BP00-0DA0 (VPE: 1 unit)

6ES7193-6BP00-2DA0 (VPE: 10 units)

## View

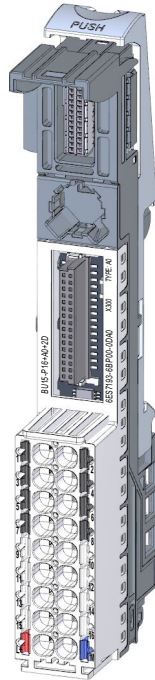

Figure 4-3 BU type A0, light-colored version, without AUX terminals

## Properties

- BaseUnit suitable for all I/O modules of the BaseUnit type "A0/A1". Can be recognized by the laser inscription on the front and/or the last two digits of the article number.
  - Supply voltage (L+ terminal, ground): Max. 24 V DC/10 A
  - Current-carrying capacity per process terminal (terminal 1 to 16): Max. 2 A
- The BaseUnit opens up a new potential group. The self-assembling voltage buses P1 and P2, and the AUX busbar are interrupted to the left-hand neighboring module (BaseUnit, interface module).
- No access to the AUX busbar via terminals
- 16 terminals to the process (assignment through the I/O module)
- Connection system in the form of push-in terminals Connection cross-sections are available in the ET 200SP System Manual (<https://support.industry.siemens.com/cs/ww/en/view/58649293>).

## Maximum configuration per potential group

The number of I/O modules that can be used per potential group depends on the following factors:

1. Total power requirement of all I/O modules operated on this potential group
2. Total power requirement of all loads connected externally to this potential group

The total current calculated according to item 1. and item 2. must not exceed 10 A.

### 4.3.2 Connection

#### Pin assignment

Pin assignment for BaseUnit BU type A0, light-colored version, without AUX terminals	
Terminal	Descriptions
1 to 16	Assignment is determined by the I/O module. You can find additional information in the I/O Module manual. <a href="http://support.automation.siemens.com/WW/view/en/55679691/133300">http://support.automation.siemens.com/WW/view/en/55679691/133300</a>
(AUX)	No access to the AUX busbar via terminals
L+ / M	L+: Rated supply voltage 24 V DC with max. 10 A M: Ground

#### Block diagram

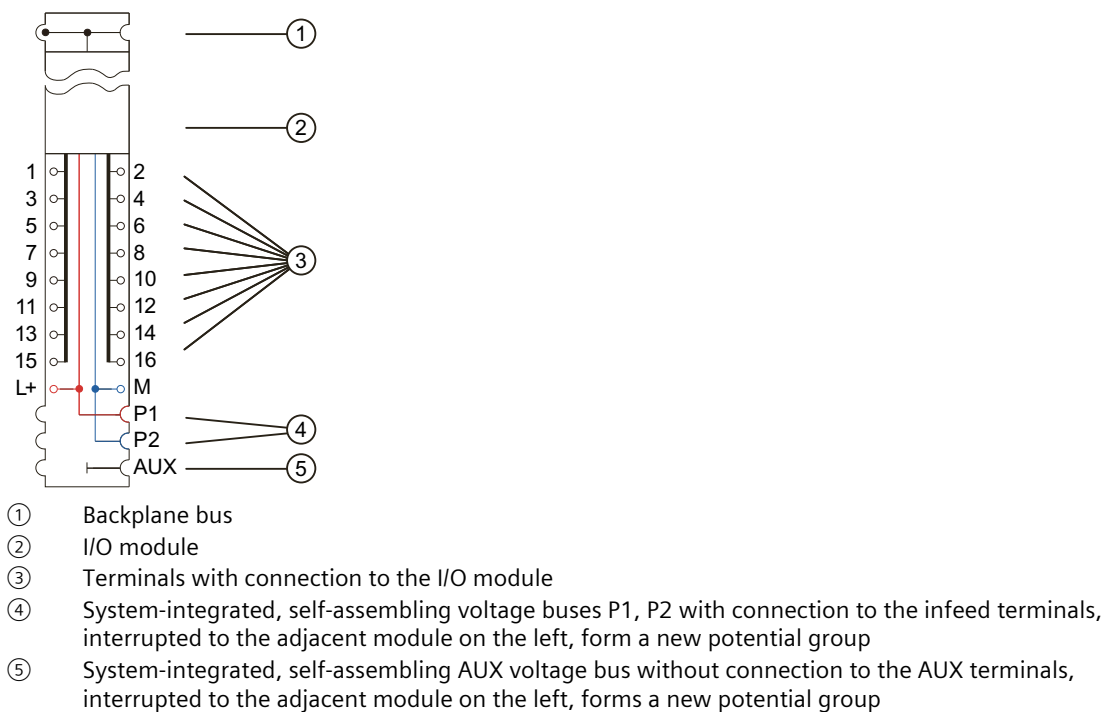

Figure 4-4 Block diagram of the BU type A0, light-colored version, without AUX terminals

### 4.3.3 Technical specifications

#### Technical specifications of the BaseUnit BU type A0, light-colored version, without AUX terminals

Article number	6ES7193-6BP20-2DA0
<b>General information</b>	
Product type designation	BU type A0

<b>Article number</b>	<b>6ES7193-6BP20-2DA0</b>
HW functional status	From FS07
<b>Supply voltage</b>	
Rated value (DC)	24 V
external protection for power supply lines	Yes; 24 V DC/10 A miniature circuit breaker with type B or C tripping characteristic
<b>Current carrying capacity</b>	
For P1 and P2 bus, max.	10 A
For AUX bus, max.	10 A
For process terminals, max.	2 A
<b>Hardware configuration</b>	
<b>Formation of potential groups</b>	
• New potential group	Yes
• Potential group continued from the left	No
<b>Potential separation</b>	
between the potential groups	Yes
<b>Isolation</b>	
Isolation tested with	707 V DC (type test)
<b>Ambient conditions</b>	
<b>Ambient temperature during operation</b>	
• horizontal installation, min.	-30 °C
• horizontal installation, max.	60 °C
• vertical installation, min.	-30 °C
• vertical installation, max.	50 °C
<b>Altitude during operation relating to sea level</b>	
• Installation altitude above sea level, max.	5 000 m; Restrictions for installation altitudes > 2 000 m, see manual
<b>Accessories</b>	
<b>Color coding labels</b>	
• for process terminals	CC00 to CC09
• for AUX terminals	CC71 to CC73
• for add-on terminals	does not exist
<b>Connection method</b>	
<b>Terminals</b>	
• Terminal type	Push-in terminal
• Conductor cross-section, min.	0.14 mm <sup>2</sup> ; AWG 26
• Conductor cross-section, max.	2.5 mm <sup>2</sup> ; AWG 14
• Number of process terminals to I/O module	16
• Number of terminals to AUX bus	10
• Number of add-on terminals	0

4.4 BU type A0, dark-colored version, with AUX terminals

<b>Article number</b>	<b>6ES7193-6BP20-2DA0</b>
<ul style="list-style-type: none"><li>Number of terminals with connection to P1 and P2 bus</li></ul>	2
<b>Dimensions</b>	
Width	15 mm
Height	141 mm
Depth	35 mm
<b>Weights</b>	
Weight, approx.	50 g

## 4.4 BU type A0, dark-colored version, with AUX terminals

### Short designation

Short designation: BU15-P16+A10+2B

### 4.4.1 Product overview

#### Delivery options (packing unit VPE)

6ES7193-6BP20-0BA0 (VPE: 1 unit)

6ES7193-6BP20-2BA0 (VPE: 10 units)

## View

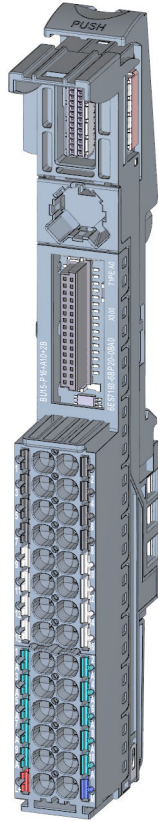

Figure 4-5 BU type A0, dark-colored version, with AUX terminals

## Properties

- BaseUnit suitable for all I/O modules of the BaseUnit type "A0/A1". Can be recognized by the laser inscription on the front and/or the last two digits of the article number.
  - Current-carrying capacity per process terminal (terminal 1 to 16): Max. 2 A
- The BaseUnit further conducts the potential group. The self-assembling voltage buses P1 and P2, and the AUX busbar are connected to the left-hand neighboring module (BaseUnit).
- Access to the AUX busbar via terminals
- 16 terminals to the process (assignment through the I/O module)
- 10 AUX terminals for connecting a protective conductor or potential. The AUX busbar is not connected to the I/O module. Max. 24 V DC/10 A
- Connection system in the form of push-in terminals Connection cross-sections are available in the ET 200SP System Manual (<https://support.industry.siemens.com/cs/ww/en/view/58649293>).

### 4.4.2 Connection

#### Pin assignment

Pin assignment for BU type A0, dark-colored version, with AUX terminals	
Terminal	Descriptions
1 to 16	Assignment is determined by the I/O module. You can find additional information in the I/O Module manual. <a href="http://support.automation.siemens.com/WW/view/en/55679691/133300">http://support.automation.siemens.com/WW/view/en/55679691/133300</a>
1 A, 2 A, 3 A, 4 A, 5 A, 6 A, 7 A, 8 A, 9 A, 10 A, AUX	Protective conductor connection or voltage bus freely usable up to 24 V DC with max. 10 A
L+ / M	L+: Rated supply voltage 24 V DC with max. 10 A M: Ground

#### Block diagram

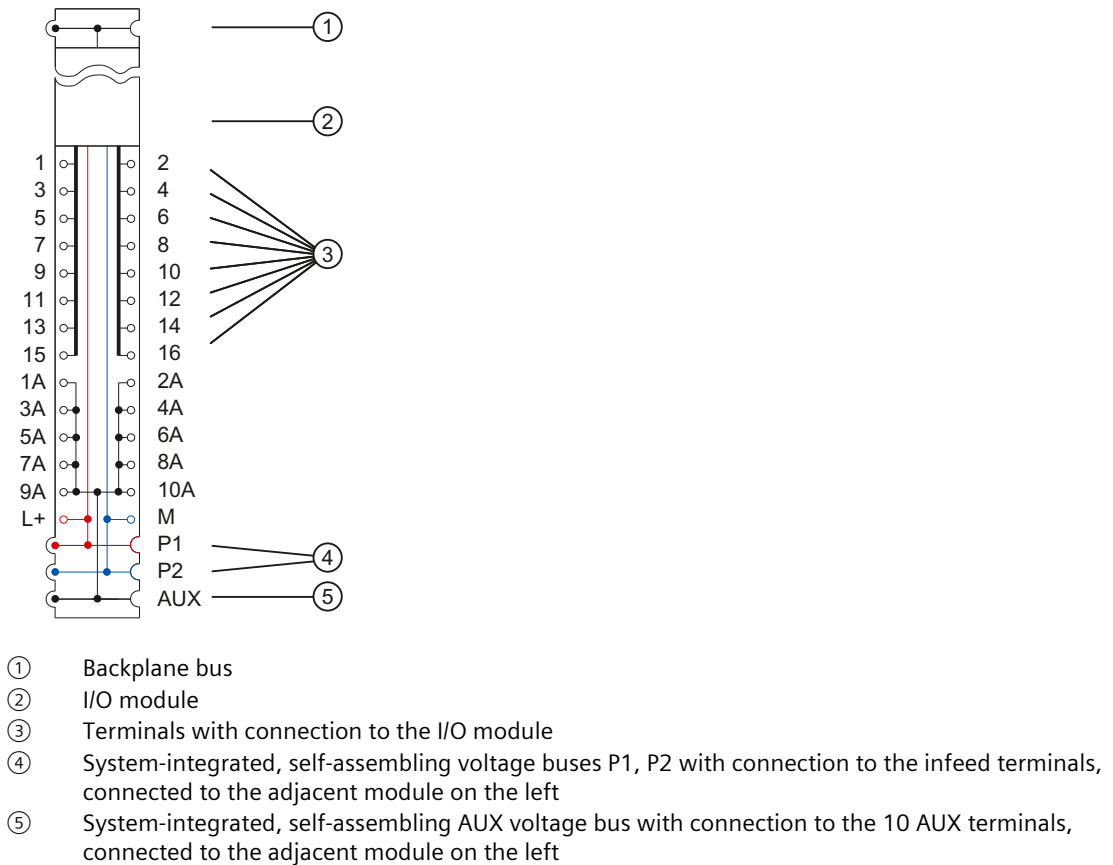

Figure 4-6 Block diagram of the BU type A0, dark-colored version, with AUX terminals



### 4.4.3 Technical specifications

#### Technical specifications of the BU type A0, dark-colored version with AUX terminals

<b>Article number</b>	<b>6ES7193-6BP20-0BA0</b>
<b>General information</b>	
Product type designation	BU type A0
HW functional status	From FS06
<b>Supply voltage</b>	
Rated value (DC)	24 V
external protection for power supply lines	Yes; 24 V DC/10 A miniature circuit breaker with type B or C tripping characteristic
<b>Current carrying capacity</b>	
For P1 and P2 bus, max.	10 A
For AUX bus, max.	10 A
For process terminals, max.	2 A
<b>Hardware configuration</b>	
<b>Formation of potential groups</b>	
• New potential group	No
• Potential group continued from the left	Yes
<b>Isolation</b>	
Isolation tested with	707 V DC (type test)
<b>Ambient conditions</b>	
<b>Ambient temperature during operation</b>	
• horizontal installation, min.	-30 °C
• horizontal installation, max.	60 °C
• vertical installation, min.	-30 °C
• vertical installation, max.	50 °C
<b>Altitude during operation relating to sea level</b>	
• Installation altitude above sea level, max.	5 000 m; Restrictions for installation altitudes > 2 000 m, see manual
<b>Accessories</b>	
<b>Color coding labels</b>	
• for process terminals	CC00 to CC09
• for AUX terminals	CC71 to CC73
• for add-on terminals	does not exist
<b>Connection method</b>	
<b>Terminals</b>	
• Terminal type	Push-in terminal
• Conductor cross-section, min.	0.14 mm <sup>2</sup> ; AWG 26
• Conductor cross-section, max.	2.5 mm <sup>2</sup> ; AWG 14
• Number of process terminals to I/O module	16

4.5 BU type A0, dark-colored version, without AUX terminals

<b>Article number</b>	<b>6ES7193-6BP20-0BA0</b>
<ul style="list-style-type: none"> <li>Number of terminals to AUX bus</li> <li>Number of add-on terminals</li> <li>Number of terminals with connection to P1 and P2 bus</li> </ul>	<p>10</p> <p>0</p> <p>2</p>
<b>Dimensions</b>	
Width	15 mm
Height	141 mm
Depth	35 mm
<b>Weights</b>	
Weight, approx.	50 g

## 4.5 BU type A0, dark-colored version, without AUX terminals

### Short designation

Short designation: BU15-P16+A0+2B

### 4.5.1 Product overview

#### Delivery options (packing unit VPE)

6ES7193-6BP00-0BA0 (VPE: 1 unit)

6ES7193-6BP00-2BA0 (VPE: 10 units)

## View

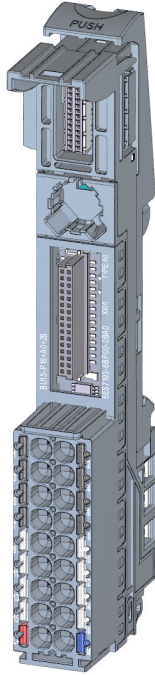

Figure 4-7 BU type A0, dark-colored version, without AUX terminals

## Properties

- BaseUnit suitable for all I/O modules of the BaseUnit type "A0/A1". Can be recognized by the laser inscription on the front and/or the last two digits of the article number.
  - Current-carrying capacity per process terminal (terminal 1 to 16): Max. 2 A
- The BaseUnit further conducts the potential group. The self-assembling voltage buses P1 and P2, and the AUX busbar are connected to the left-hand neighboring module (BaseUnit).
- No access to the AUX busbar via terminals
- 16 terminals to the process (assignment through the I/O module)
- Connection system in the form of push-in terminals Connection cross-sections are available in the ET 200SP System Manual (<https://support.industry.siemens.com/cs/ww/en/view/58649293>).

### 4.5.2 Connection

#### Pin assignment

Pin assignment for BU type A0, dark-colored version, without AUX terminals	
Terminal	Descriptions
1 to 16	Assignment is determined by the I/O module. You can find additional information in the I/O Module <a href="http://support.automation.siemens.com/WW/view/en/55679691/133300">http://support.automation.siemens.com/WW/view/en/55679691/133300</a> manual.
(AUX)	No access to the AUX busbar via terminals
L+ / M	L+: Rated supply voltage 24 V DC with max. 10 A M: Ground

#### Block diagram

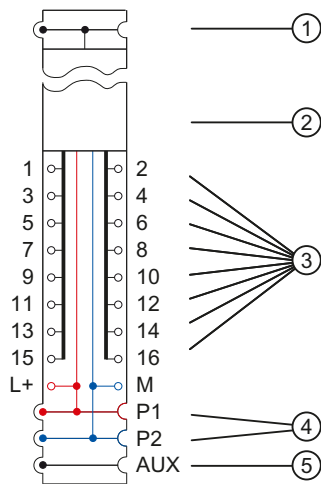

- ① Backplane bus
- ② I/O module
- ③ Terminals with connection to the I/O module
- ④ System-integrated, self-assembling voltage buses P1, P2 with connection to the infeed terminals, connected to the adjacent module on the left
- ⑤ System-integrated, self-assembling AUX voltage bus without connection to the AUX terminals, connected to the adjacent module on the left

Figure 4-8 Block diagram of the BU type A0, dark-colored version, without AUX terminals

### 4.5.3 Technical specifications

#### Technical specifications of the BU type A0, dark-colored version, without AUX terminals

Article number	6ES7193-6BP00-0BA0
<b>General information</b>	
Product type designation	BU type A0

<b>Article number</b>	<b>6ES7193-6BP00-0BA0</b>
HW functional status	From FS06
<b>Supply voltage</b>	
Rated value (DC)	24 V
external protection for power supply lines	Yes; 24 V DC/10 A miniature circuit breaker with type B or C tripping characteristic
<b>Mains filter</b>	
<ul style="list-style-type: none"> <li>integrated</li> </ul>	No
<b>Current carrying capacity</b>	
For P1 and P2 bus, max.	10 A
For process terminals, max.	2 A
<b>Hardware configuration</b>	
Automatic encoding	Yes
<b>Formation of potential groups</b>	
<ul style="list-style-type: none"> <li>New potential group</li> </ul>	No
<ul style="list-style-type: none"> <li>Potential group continued from the left</li> </ul>	Yes
<b>Isolation</b>	
Isolation tested with	707 V DC (type test)
<b>Ambient conditions</b>	
<b>Ambient temperature during operation</b>	
<ul style="list-style-type: none"> <li>horizontal installation, min.</li> </ul>	-30 °C
<ul style="list-style-type: none"> <li>horizontal installation, max.</li> </ul>	60 °C
<ul style="list-style-type: none"> <li>vertical installation, min.</li> </ul>	-30 °C
<ul style="list-style-type: none"> <li>vertical installation, max.</li> </ul>	50 °C
<b>Altitude during operation relating to sea level</b>	
<ul style="list-style-type: none"> <li>Installation altitude above sea level, max.</li> </ul>	5 000 m; Restrictions for installation altitudes > 2 000 m, see manual
<b>Accessories</b>	
<b>Color coding labels</b>	
<ul style="list-style-type: none"> <li>for process terminals</li> </ul>	CC00 to CC09
<ul style="list-style-type: none"> <li>for AUX terminals</li> </ul>	does not exist
<ul style="list-style-type: none"> <li>for add-on terminals</li> </ul>	does not exist
<b>Connection method</b>	
<b>Terminals</b>	
<ul style="list-style-type: none"> <li>Terminal type</li> </ul>	Push-in terminal
<ul style="list-style-type: none"> <li>Conductor cross-section, min.</li> </ul>	0.14 mm <sup>2</sup> ; AWG 26
<ul style="list-style-type: none"> <li>Conductor cross-section, max.</li> </ul>	2.5 mm <sup>2</sup> ; AWG 14
<ul style="list-style-type: none"> <li>Number of process terminals to I/O module</li> </ul>	16; Pro slot
<ul style="list-style-type: none"> <li>Number of terminals to AUX bus</li> </ul>	0
<ul style="list-style-type: none"> <li>Number of add-on terminals</li> </ul>	0

4.6 BU type A1, light-colored version, with additional terminals

<b>Article number</b>	<b>6ES7193-6BP00-0BA0</b>
<ul style="list-style-type: none"><li>Number of terminals with connection to P1 and P2 bus</li></ul>	2; Pro slot
<b>Dimensions</b>	
Width	15 mm
Height	117 mm
Depth	35 mm
<b>Weights</b>	
Weight, approx.	40 g

## 4.6 BU type A1, light-colored version, with additional terminals

### Short designation

Short designation: BU15-P16+A0+12D/T

### 4.6.1 Product overview

#### Delivery options (packing unit VPE)

6ES7193-6BP40-0DA1 (VPE: 1 unit)

## View

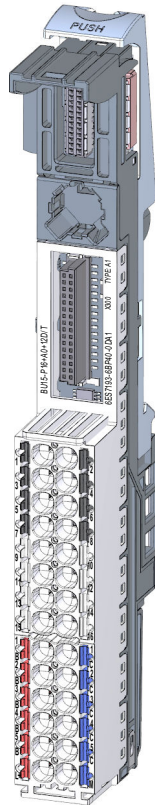

Figure 4-9 BU type A1, light-colored version, with additional terminals

## Properties

- BaseUnit suitable for all I/O modules of the BaseUnit type "A1". Can be recognized by the laser inscription on the front and/or the last two digits of the article number.

**NOTE**

Using another I/O module can trigger an internal, non-exchangeable fuse. You then have to exchange the terminal box.

- Supply voltage (L+ terminal, ground): Max. 24 V DC/10 A
- Current-carrying capacity per process terminal (terminal 1 to 16): Max. 2 A
- The BaseUnit opens up a new potential group. The self-assembling voltage buses P1 and P2, and the AUX busbar are interrupted to the left-hand neighboring module (BaseUnit, interface module).
- No access to the AUX busbar via terminals
- 16 terminals to the process (assignment through the I/O module)

4.6 BU type A1, light-colored version, with additional terminals

- 2x5 additional terminals for supplying a supply voltage up to 24 V DC/ 10 A. The additional terminals are not connected to the I/O module.
- Recording of the terminal temperature for internal temperature compensation at connected thermocouples
- Connection system in the form of push-in terminals Connection cross-sections are available in the ET 200SP System Manual (<https://support.industry.siemens.com/cs/ww/en/view/58649293>).

**Maximum configuration per potential group**

The number of I/O modules that can be used per potential group depends on the following factors:

1. Total power requirement of all I/O modules operated on this potential group
  2. Total power requirement of all loads connected externally to this potential group
- The total current calculated according to item 1. and item 2. must not exceed 10 A.

**4.6.2 Connection**

**Pin assignment**

Pin assignment for BU type A1, light-colored version, with additional terminals	
Terminal	Descriptions
1 to 16	Assignment is determined by the I/O module. You can find additional information in the I/O Module manual. ( <a href="http://support.automation.siemens.com/WW/view/en/55679691/133300">http://support.automation.siemens.com/WW/view/en/55679691/133300</a> )
1 B, 2 B, 3 B, 4 B, 5 B / 1 C, 2 C, 3 C, 4 C, 5 C	2 x 5 add-on terminals for the infeed of a supply voltage up to 24 V DC with max. 10 A
(AUX)	No access to the AUX busbar via terminals
L+ / M	L+: Rated supply voltage 24 V DC with max. 10 A M: Ground



## Block diagram

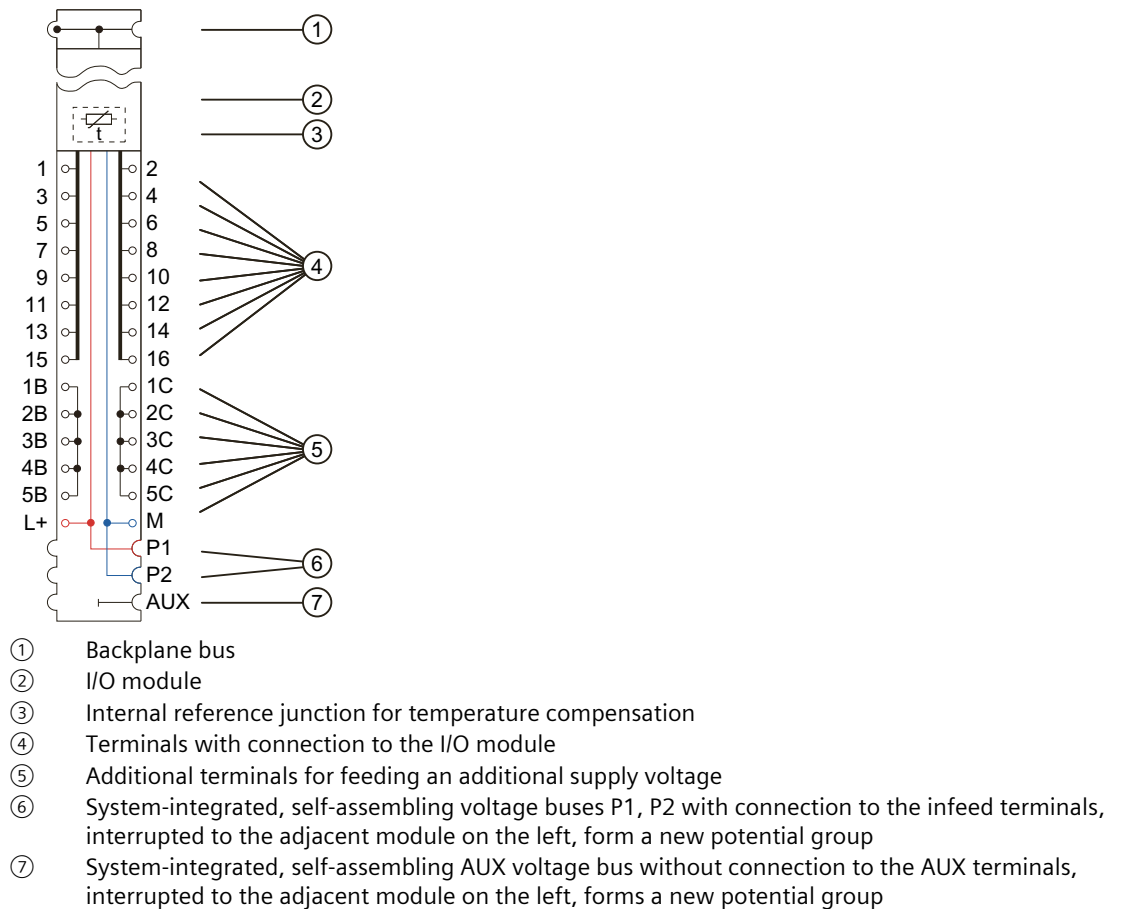

Figure 4-10 Block diagram of the BU type A1, light-colored version, with additional terminals

### 4.6.3 Technical specifications

#### Technical specifications of the BU type A1, light-colored version, with additional terminals

Article number	6ES7193-6BP40-0DA1
<b>General information</b>	
Product type designation	BU type A1
HW functional status	FS10 and higher
<b>Supply voltage</b>	
Rated value (DC)	24 V
external protection for power supply lines	Yes; 24 V DC/10 A miniature circuit breaker with type B or C tripping characteristic
<b>Current carrying capacity</b>	
For P1 and P2 bus, max.	10 A
For process terminals, max.	2 A
<b>Hardware configuration</b>	
Additional terminals	Yes

## 4.6 BU type A1, light-colored version, with additional terminals

<b>Article number</b>	<b>6ES7193-6BP40-0DA1</b>
Temperature sensor	Yes
<b>Formation of potential groups</b>	
• New potential group	Yes
• Potential group continued from the left	No
<b>Potential separation</b>	
between the potential groups	Yes
<b>Isolation</b>	
Isolation tested with	707 V DC (type test)
<b>Ambient conditions</b>	
<b>Ambient temperature during operation</b>	
• horizontal installation, min.	-30 °C
• horizontal installation, max.	60 °C
• vertical installation, min.	-30 °C
• vertical installation, max.	50 °C
<b>Altitude during operation relating to sea level</b>	
• Installation altitude above sea level, max.	5 000 m; Restrictions for installation altitudes > 2 000 m, see manual
<b>Accessories</b>	
<b>Color coding labels</b>	
• for process terminals	CC00 to CC09
• for AUX terminals	does not exist
• for add-on terminals	CC74
<b>Connection method</b>	
<b>Terminals</b>	
• Terminal type	Push-in terminal
• Conductor cross-section, min.	0.14 mm <sup>2</sup> ; AWG 26
• Conductor cross-section, max.	2.5 mm <sup>2</sup> ; AWG 14
• Number of process terminals to I/O module	16
• Number of terminals to AUX bus	0
• Number of add-on terminals	2x5
• Number of terminals with connection to P1 and P2 bus	2
<b>Dimensions</b>	
Width	15 mm
Height	141 mm
Depth	35 mm
<b>Weights</b>	
Weight, approx.	50 g

## 4.7 BU type A1, light-colored version, without additional terminals

### Short designation

Short designation: BU15-P16+A0+2D/T

### 4.7.1 Product overview

#### Delivery options (packing unit VPE)

6ES7193-6BP00-0DA1 (VPE: 1 unit)

#### View

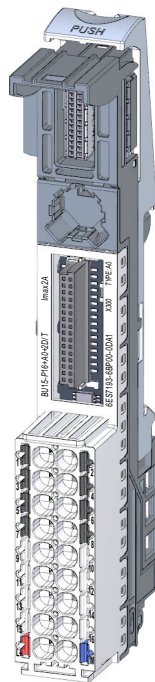

Figure 4-11 BU type A1, light-colored version, without additional terminals

### Properties

- BaseUnit suitable for all I/O modules of the BaseUnit type "A1". Can be recognized by the laser inscription on the front and/or the last two digits of the article number.

---

#### NOTE

Using another I/O module can trigger an internal, non-exchangeable fuse. You then have to exchange the terminal box.

---

- Supply voltage (L+ terminal, ground): Max. 24 V DC/10 A
- Current-carrying capacity per process terminal (terminal 1 to 16): Max. 2 A
- The BaseUnit opens up a new potential group. The self-assembling voltage buses P1 and P2, and the AUX busbar are interrupted to the left-hand neighboring module (BaseUnit, interface module).

4.7 BU type A1, light-colored version, without additional terminals

- No access to the AUX busbar via terminals
- 16 terminals to the process (assignment through the I/O module)
- Recording of the terminal temperature for internal temperature compensation at connected thermocouples
- Connection system in the form of push-in terminals Connection cross-sections are available in the ET 200SP System Manual (<https://support.industry.siemens.com/cs/ww/en/view/58649293>).

**Maximum configuration per potential group**

The number of I/O modules that can be used per potential group depends on the following factors:

1. Total power requirement of all I/O modules operated on this potential group
2. Total power requirement of all loads connected externally to this potential group

The total current calculated according to item 1. and item 2. must not exceed 10 A.

**4.7.2 Connection**

**Pin assignment**

Pin assignment for BU type A1, light-colored version, without additional terminals	
Terminal	Descriptions
1 to 16	Assignment is determined by the I/O module. You can find additional information in the I/O Module ( <a href="http://support.automation.siemens.com/WW/view/en/55679691/133300">http://support.automation.siemens.com/WW/view/en/55679691/133300</a> ) manual.
(AUX)	No access to the AUX busbar via terminals
L+, P1 / M, P2	L+: Rated supply voltage 24 V DC with max. 10 A M: Ground

**Block diagram**

## 4.7 BU type A1, light-colored version, without additional terminals

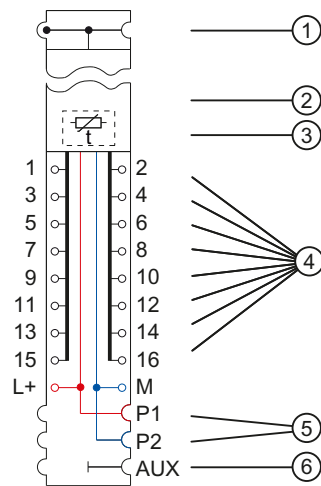

- ① Backplane bus
- ② I/O module
- ③ Internal reference junction for temperature compensation
- ④ Terminals with connection to the I/O module
- ⑤ System-integrated, self-assembling voltage buses P1, P2 with connection to the infeed terminals, interrupted to the adjacent module on the left, form a new potential group
- ⑥ System-integrated, self-assembling AUX voltage bus without connection to the AUX terminals, interrupted to the adjacent module on the left, forms a new potential group

Figure 4-12 Block diagram of the BU type A1, light-colored version, without additional terminals

## 4.7.3 Technical specifications

## Technical specifications of the BU type A1, light-colored version, without additional terminals

<b>Article number</b>	<b>6ES7193-6BP00-0BA1</b>
<b>General information</b>	
Product type designation	BU type A1
HW functional status	FS10 and higher
<b>Supply voltage</b>	
Rated value (DC)	24 V
external protection for power supply lines	Yes; 24 V DC/10 A miniature circuit breaker with type B or C tripping characteristic
<b>Current carrying capacity</b>	
For P1 and P2 bus, max.	10 A
For process terminals, max.	2 A
<b>Hardware configuration</b>	
Temperature sensor	Yes
<b>Formation of potential groups</b>	
• New potential group	No
• Potential group continued from the left	Yes
<b>Isolation</b>	
Isolation tested with	707 V DC (type test)

## 4.8 BU type A1, dark-colored version, with additional terminals

<b>Article number</b>	<b>6ES7193-6BP00-0BA1</b>
<b>Ambient conditions</b>	
<b>Ambient temperature during operation</b>	
<ul style="list-style-type: none"> <li>horizontal installation, min.</li> </ul>	-30 °C
<ul style="list-style-type: none"> <li>horizontal installation, max.</li> </ul>	60 °C
<ul style="list-style-type: none"> <li>vertical installation, min.</li> </ul>	-30 °C
<ul style="list-style-type: none"> <li>vertical installation, max.</li> </ul>	50 °C
<b>Altitude during operation relating to sea level</b>	
<ul style="list-style-type: none"> <li>Installation altitude above sea level, max.</li> </ul>	5 000 m; Restrictions for installation altitudes > 2 000 m, see manual
<b>Accessories</b>	
<b>Color coding labels</b>	
<ul style="list-style-type: none"> <li>for process terminals</li> </ul>	CC00 to CC09
<ul style="list-style-type: none"> <li>for AUX terminals</li> </ul>	does not exist
<ul style="list-style-type: none"> <li>for add-on terminals</li> </ul>	does not exist
<b>Connection method</b>	
<b>Terminals</b>	
<ul style="list-style-type: none"> <li>Terminal type</li> </ul>	Push-in terminal
<ul style="list-style-type: none"> <li>Conductor cross-section, min.</li> </ul>	0.14 mm <sup>2</sup> ; AWG 26
<ul style="list-style-type: none"> <li>Conductor cross-section, max.</li> </ul>	2.5 mm <sup>2</sup> ; AWG 14
<ul style="list-style-type: none"> <li>Number of process terminals to I/O module</li> </ul>	16
<ul style="list-style-type: none"> <li>Number of terminals to AUX bus</li> </ul>	0
<ul style="list-style-type: none"> <li>Number of add-on terminals</li> </ul>	0
<ul style="list-style-type: none"> <li>Number of terminals with connection to P1 and P2 bus</li> </ul>	2
<b>Dimensions</b>	
Width	15 mm
Height	117 mm
Depth	35 mm
<b>Weights</b>	
Weight, approx.	40 g

## 4.8 BU type A1, dark-colored version, with additional terminals

### Short designation

Short designation: BU15-P16+A0+12B/T

### 4.8.1 Product overview

#### Delivery options (packing unit VPE)

6ES7193-6BP40-0BA1 (VPE: 1 unit)

## View

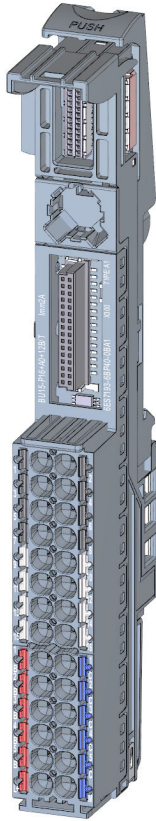

Figure 4-13 BU type A1, dark-colored version, with additional terminals

## Properties

- BaseUnit suitable for all I/O modules of the BaseUnit type "A1". Can be recognized by the laser inscription on the front and/or the last two digits of the article number.

---

### NOTE

Using another I/O module can trigger an internal, non-exchangeable fuse. You then have to exchange the terminal box.

---

- Current-carrying capacity per process terminal (terminal 1 to 16): Max. 2 A
- The BaseUnit further conducts the potential group. The self-assembling voltage buses P1 and P2, and the AUX busbar are connected to the left-hand neighboring module (BaseUnit).
- No access to the AUX busbar via terminals
- 16 terminals to the process (assignment through the I/O module)

4.8 BU type A1, dark-colored version, with additional terminals

- 2x5 additional terminals for supplying a supply voltage up to 24 V DC/ 10 A. The additional terminals are not connected to the I/O module.
- Recording of the terminal temperature for internal temperature compensation at connected thermocouples
- Connection system in the form of push-in terminals Connection cross-sections are available in the ET 200SP System Manual (<https://support.industry.siemens.com/cs/ww/en/view/58649293>).

4.8.2 Connection

Pin assignment

Pin assignment for BU type A1, dark-colored version, with additional terminals	
Terminal	Descriptions
1 to 16	Assignment is determined by the I/O module. You can find additional information in the I/O Module manual. ( <a href="http://support.automation.siemens.com/WW/view/en/55679691/133300">http://support.automation.siemens.com/WW/view/en/55679691/133300</a> )
1 B, 2 B, 3 B, 4 B, 5 B / 1 C, 2 C, 3 C, 4 C, 5 C	2 x 5 add-on terminals for the infeed of a supply voltage up to 24 V DC with max. 10 A
(AUX)	No access to the AUX busbar via terminals
L+, P1 / M, P2	L+: Rated supply voltage 24 V DC with max. 10 A M: Ground

Block diagram

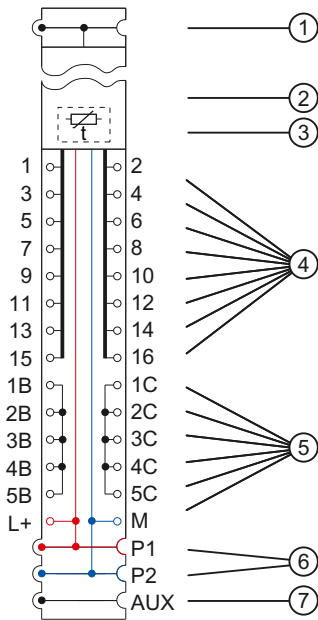



## 4.8 BU type A1, dark-colored version, with additional terminals

- ① Backplane bus
- ② I/O module
- ③ Internal reference junction for temperature compensation
- ④ Terminals with connection to the I/O module
- ⑤ Additional terminals for feeding an additional supply voltage
- ⑥ System-integrated, self-assembling voltage buses P1, P2 with connection to the infeed terminals, connected to the adjacent module on the left
- ⑦ System-integrated, self-assembling AUX voltage bus without connection to the AUX terminals, connected to the adjacent module on the left

Figure 4-14 Block diagram of the BU type A1, dark-colored version, with additional terminals

### 4.8.3 Technical specifications

#### Technical specifications of the BU type A1, dark-colored version with additional terminals

<b>Article number</b>	<b>6ES7193-6BP00-0DA1</b>
<b>General information</b>	
Product type designation	BU type A1
HW functional status	FS10 and higher
<b>Supply voltage</b>	
Rated value (DC)	24 V
external protection for power supply lines	Yes; 24 V DC/10 A miniature circuit breaker with type B or C tripping characteristic
<b>Current carrying capacity</b>	
For P1 and P2 bus, max.	10 A
For process terminals, max.	2 A
<b>Hardware configuration</b>	
Temperature sensor	Yes
<b>Formation of potential groups</b>	
• New potential group	Yes
• Potential group continued from the left	No
<b>Potential separation</b>	
between the potential groups	Yes
<b>Isolation</b>	
Isolation tested with	707 V DC (type test)
<b>Ambient conditions</b>	
<b>Ambient temperature during operation</b>	
• horizontal installation, min.	-30 °C
• horizontal installation, max.	60 °C
• vertical installation, min.	-30 °C
• vertical installation, max.	50 °C
<b>Altitude during operation relating to sea level</b>	
• Installation altitude above sea level, max.	5 000 m; Restrictions for installation altitudes > 2 000 m, see manual
<b>Accessories</b>	

4.9 BU type A1, dark-colored version, without additional terminals

<b>Article number</b>	<b>6ES7193-6BP00-0DA1</b>
<b>Color coding labels</b>	
<ul style="list-style-type: none"> <li>• for process terminals</li> <li>• for AUX terminals</li> <li>• for add-on terminals</li> </ul>	<p>CC00 to CC09</p> <p>does not exist</p> <p>does not exist</p>
<b>Connection method</b>	
<b>Terminals</b>	
<ul style="list-style-type: none"> <li>• Terminal type</li> <li>• Conductor cross-section, min.</li> <li>• Conductor cross-section, max.</li> <li>• Number of process terminals to I/O module</li> <li>• Number of terminals to AUX bus</li> <li>• Number of add-on terminals</li> <li>• Number of terminals with connection to P1 and P2 bus</li> </ul>	<p>Push-in terminal</p> <p>0.14 mm<sup>2</sup>; AWG 26</p> <p>2.5 mm<sup>2</sup>; AWG 14</p> <p>16</p> <p>0</p> <p>0</p> <p>2</p>
<b>Dimensions</b>	
Width	15 mm
Height	117 mm
Depth	35 mm
<b>Weights</b>	
Weight, approx.	40 g

## 4.9 BU type A1, dark-colored version, without additional terminals

### Short designation

Short designation: BU15-P16+A0+2B/T

### 4.9.1 Product overview

#### Delivery options (packing unit VPE)

6ES7193-6BP00-0BA1 (VPE: 1 unit)

## View

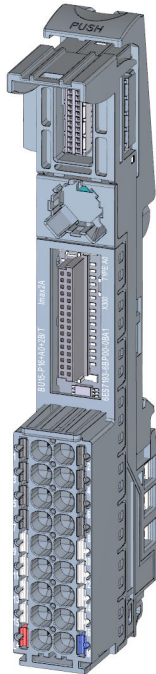

Figure 4-15 BU type A1, dark-colored version, without additional terminals

## Properties

- BaseUnit suitable for all I/O modules of the BaseUnit type "A1". Can be recognized by the laser inscription on the front and/or the last two digits of the article number.

---

### NOTE

Using another I/O module can trigger an internal, non-exchangeable fuse. You then have to exchange the terminal box.

---

- Current-carrying capacity per process terminal (terminal 1 to 16): Max. 2 A
- The BaseUnit further conducts the potential group. The self-assembling voltage buses P1 and P2, and the AUX busbar are connected to the left-hand neighboring module (BaseUnit).
- No access to the AUX busbar via terminals
- 16 terminals to the process (assignment through the I/O module)
- Recording of the terminal temperature for internal temperature compensation at connected thermocouples
- Connection system in the form of push-in terminals Connection cross-sections are available in the ET 200SP System Manual (<https://support.industry.siemens.com/cs/ww/en/view/58649293>).

### 4.9.2 Connection

#### Pin assignment

Pin assignment for BU type A1, dark-colored version, without additional terminals	
Terminal	Descriptions
1 to 16	Assignment is determined by the I/O module. You can find additional information in the I/O Module manual. <a href="http://support.automation.siemens.com/WW/view/en/55679691/133300">http://support.automation.siemens.com/WW/view/en/55679691/133300</a>
(AUX)	No access to the AUX busbar via terminals
L+, P1 / M, P2	L+: Rated supply voltage 24 V DC with max. 10 A M: Ground

#### Block diagram

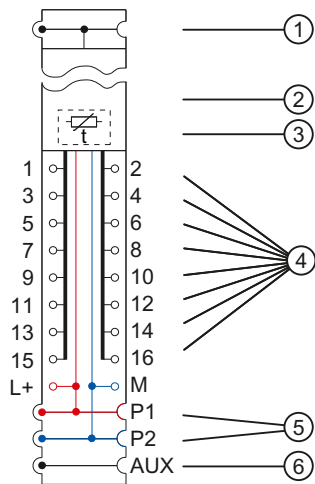

- ① Backplane bus
- ② I/O module
- ③ Internal reference junction for temperature compensation
- ④ Terminals with connection to the I/O module
- ⑤ System-integrated, self-assembling voltage buses P1, P2 with connection to the infeed terminals, connected to the adjacent module on the left
- ⑥ System-integrated, self-assembling AUX voltage bus without connection to the AUX terminals, connected to the adjacent module on the left

Figure 4-16 Block diagram of the BU type A1, dark-colored version, without additional terminals

### 4.9.3 Technical specifications

#### Technical specifications of the BU type A1, dark-colored version, without additional terminals

Article number	6ES7193-6BP00-0BA1
<b>General information</b>	
Product type designation	BU type A1

## 4.9 BU type A1, dark-colored version, without additional terminals

<b>Article number</b>	<b>6ES7193-6BP00-0BA1</b>
HW functional status	FS10 and higher
<b>Supply voltage</b>	
Rated value (DC)	24 V
external protection for power supply lines	Yes; 24 V DC/10 A miniature circuit breaker with type B or C tripping characteristic
<b>Current carrying capacity</b>	
For P1 and P2 bus, max.	10 A
For process terminals, max.	2 A
<b>Hardware configuration</b>	
Temperature sensor	Yes
<b>Formation of potential groups</b>	
• New potential group	No
• Potential group continued from the left	Yes
<b>Isolation</b>	
Isolation tested with	707 V DC (type test)
<b>Ambient conditions</b>	
<b>Ambient temperature during operation</b>	
• horizontal installation, min.	-30 °C
• horizontal installation, max.	60 °C
• vertical installation, min.	-30 °C
• vertical installation, max.	50 °C
<b>Altitude during operation relating to sea level</b>	
• Installation altitude above sea level, max.	5 000 m; Restrictions for installation altitudes > 2 000 m, see manual
<b>Accessories</b>	
<b>Color coding labels</b>	
• for process terminals	CC00 to CC09
• for AUX terminals	does not exist
• for add-on terminals	does not exist
<b>Connection method</b>	
<b>Terminals</b>	
• Terminal type	Push-in terminal
• Conductor cross-section, min.	0.14 mm <sup>2</sup> ; AWG 26
• Conductor cross-section, max.	2.5 mm <sup>2</sup> ; AWG 14
• Number of process terminals to I/O module	16
• Number of terminals to AUX bus	0
• Number of add-on terminals	0
• Number of terminals with connection to P1 and P2 bus	2
<b>Dimensions</b>	

4.10 BU type B0, dark-colored version, with AUX terminals, supply over P1, P2 busbar

<b>Article number</b>	<b>6ES7193-6BP00-0BA1</b>
Width	15 mm
Height	117 mm
Depth	35 mm
<b>Weights</b>	
Weight, approx.	40 g

## 4.10 BU type B0, dark-colored version, with AUX terminals, supply over P1, P2 busbar

### Short designation

Short designation: BU20-P12+A4+0B

### 4.10.1 Product overview

#### Delivery options (packing unit VPE)

6ES7193-6BP20-0BBO (VPE: 1 unit)

6ES7193-6BP20-2BBO (VPE: 10 units)

### View

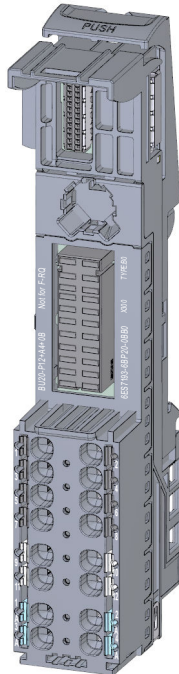

Figure 4-17 BU type B0, dark-colored version, with AUX terminals, supply over P1, P2 busbar

## 4.10 BU type B0, dark-colored version, with AUX terminals, supply over P1, P2 busbar

**Properties**

- BaseUnit suitable for all I/O modules of the BaseUnit type "B0/B1". Can be recognized by the laser inscription on the front and/or the last two digits of the article number.
  - Current-carrying capacity per process terminal (terminal 1 to 12): Max. 5 A
- The BaseUnit further conducts the potential group. The self-assembling voltage buses P1 and P2, and the AUX busbar are connected to the left-hand neighboring module (BaseUnit).
- Access to the AUX busbar via terminals
- 12 terminals to the process (assignment with the I/O module)
- Connection system in the form of push-in terminals Connection cross-sections are available in the ET 200SP System Manual (<https://support.industry.siemens.com/cs/ww/en/view/58649293>).

**4.10.2 Connecting****Pin assignment**

Pin assignment for BU type B0, dark-colored version, with AUX terminals, supply over P1, P2 busbar	
Terminal	Descriptions
1 to 12	Assignment is determined by the I/O module. You can find additional information in the I/O Module ( <a href="http://support.automation.siemens.com/WW/view/en/55679691/133300">http://support.automation.siemens.com/WW/view/en/55679691/133300</a> ) manual.
1 A, 2 A, 3 A, 4 A, AUX	Protective conductor connection or voltage bus. Freely usable up to 230 V AC/DC with max. 10 A. If you connect a voltage, this voltage must belong to the same potential group as the rated supply voltage.

**Block diagram**

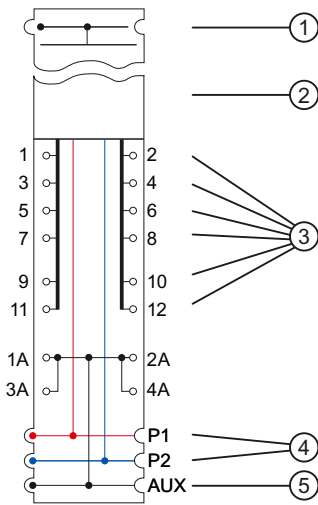

- ① Backplane bus
- ② I/O module
- ③ Terminals with connection to the I/O module
- ④ System-integrated, self-assembling voltage buses P1, P2 with connection to the infeed terminals, connected to the adjacent module on the left
- ⑤ System-integrated, self-assembling AUX voltage bus with connection to the 4 AUX terminals, connected to the adjacent module on the left

Figure 4-18 Block diagram of the BU type B0, dark-colored version, with AUX terminals, supply over P1, P2 busbar

**4.10.3 Technical specifications**

**Technical specifications of the BU type B0, dark-colored version, with AUX terminals, supply over P1, P2 busbar**

<b>Article number</b>	<b>6ES7193-6BP20-0BB0</b>
<b>General information</b>	
Product type designation	ET 200SP, BaseUnit BU-Typ B0, PU 1
HW functional status	FS10 and higher
<b>Supply voltage</b>	
Rated value (DC)	See manual
• For P1 and P2 bus	24 V
• For AUX bus	24 V; Equal potential group to P1/P2 bus or PE
• for process terminals	24 V
Rated value (AC)	See manual
• For P1 and P2 bus	230 V
• For AUX bus	230 V; Equal potential group to P1/P2 bus or PE
• for process terminals	230 V
<b>Mains filter</b>	



## 4.10 BU type B0, dark-colored version, with AUX terminals, supply over P1, P2 busbar

<b>Article number</b>	<b>6ES7193-6BP20-0BB0</b>
<ul style="list-style-type: none"> <li>integrated</li> </ul>	No
<b>Current carrying capacity</b>	
up to 60 °C, max.	10 A
For P1 and P2 bus, max.	10 A
For AUX bus, max.	10 A
For process terminals, max.	5 A
<b>Hardware configuration</b>	
Automatic encoding	Yes
<b>Potential separation</b>	
between backplane bus and supply voltage	Yes
between process terminals and supply voltage	Yes
between power bus and supply voltage	No
<b>Isolation</b>	
Isolation tested with	3 100 V DC
<b>Ambient conditions</b>	
<b>Ambient temperature during operation</b>	
<ul style="list-style-type: none"> <li>horizontal installation, min.</li> </ul>	-30 °C
<ul style="list-style-type: none"> <li>horizontal installation, max.</li> </ul>	60 °C
<ul style="list-style-type: none"> <li>vertical installation, min.</li> </ul>	-30 °C
<ul style="list-style-type: none"> <li>vertical installation, max.</li> </ul>	50 °C
<b>Altitude during operation relating to sea level</b>	
<ul style="list-style-type: none"> <li>Installation altitude above sea level, max.</li> </ul>	2 000 m; On request: Installation altitudes greater than 2 000 m
<b>Accessories</b>	
<b>Color coding labels</b>	
<ul style="list-style-type: none"> <li>for AUX terminals</li> </ul>	CC81 to CC83
<b>Connection method</b>	
<b>Terminals</b>	
<ul style="list-style-type: none"> <li>Terminal type</li> </ul>	Push-in terminal
<ul style="list-style-type: none"> <li>Conductor cross-section, min.</li> </ul>	0.14 mm <sup>2</sup> ; AWG 26
<ul style="list-style-type: none"> <li>Conductor cross-section, max.</li> </ul>	2.5 mm <sup>2</sup> ; AWG 14
<ul style="list-style-type: none"> <li>Number of process terminals to I/O module</li> </ul>	12; Pro slot
<ul style="list-style-type: none"> <li>Number of terminals to AUX bus</li> </ul>	0
<ul style="list-style-type: none"> <li>Number of add-on terminals</li> </ul>	0
<ul style="list-style-type: none"> <li>Number of terminals with connection to P1 and P2 bus</li> </ul>	0; Pro slot
<b>Dimensions</b>	
Width	20 mm
Height	117 mm

4.11 BU type B1, dark-colored version, without AUX terminals, supply over supply terminals

<b>Article number</b>	<b>6ES7193-6BP20-0BB0</b>
Depth	35 mm
<b>Weights</b>	
Weight, approx.	48 g

## 4.11 BU type B1, dark-colored version, without AUX terminals, supply over supply terminals

### Short designation

Short designation: BU20-P12+A0+4B

### 4.11.1 Product overview

#### Delivery options (packing unit VPE)

6ES7193-6BP20-0BB1 (VPE: 1 unit)

6ES7193-6BP20-2BB1 (VPE: 10 units)

### View

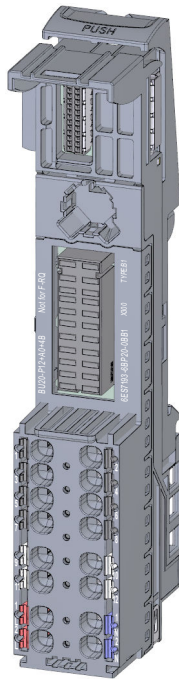

Figure 4-19 BU type B1, dark-colored version, without AUX terminals, supply over supply terminals

## 4.11 BU type B1, dark-colored version, without AUX terminals, supply over supply terminals

**Properties**

- BaseUnit suitable for all I/O modules of the BaseUnit type "B1". Can be recognized by the laser inscription on the front and/or the last two digits of the article number.
  - Current-carrying capacity per process terminal (terminal 1 to 12): Max. 5 A
- The BaseUnit further conducts the potential group. The self-assembling voltage buses P1 and P2, and the AUX busbar are connected to the left-hand neighboring module (BaseUnit).
- No access to the power and AUX busbars via terminals
- Not suitable for the shield connection terminals.
- 12 terminals to the process (assignment with the I/O module)
- Connection system in the form of push-in terminals Connection cross-sections are available in the ET 200SP System Manual (<https://support.industry.siemens.com/cs/ww/en/view/58649293>).

**4.11.2 Connecting up****Pin assignment**

Pin assignment for BU type B1, dark-colored version, without AUX terminals, supply over supply terminals	
Terminal	Descriptions
1 to 12	Assignment is determined by the I/O module. You can find additional information in the I/O Module manual. ( <a href="http://support.automation.siemens.com/WW/view/de/55679691/133300">http://support.automation.siemens.com/WW/view/de/55679691/133300</a> )
(AUX)	No access to the AUX busbar via terminals
1 L, 2 L, (P1) / 1 N, 2 N, (P2)	1 L, 2 L: Rated supply voltage up to 230 V AC with max. 10 A 1 N, 2 N: Neutral/Ground

**Block diagram**

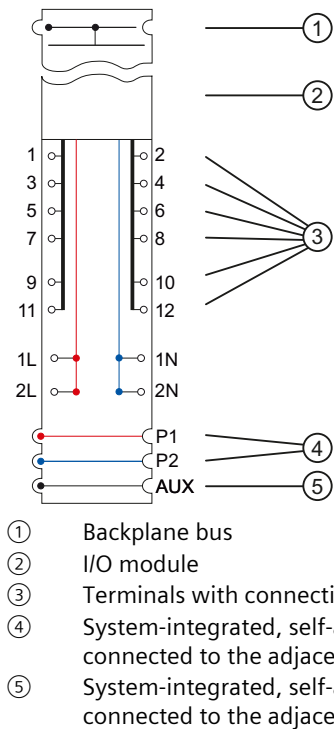

Figure 4-20 Block diagram of the BU type B1, dark-colored version, without AUX terminals, supply over supply terminals

**4.11.3 Technical specifications**

**Technical specifications of the BU type B1, dark-colored version, without AUX terminals, supply over infeed terminals**

Article number	6ES7193-6BP20-0BB1
<b>General information</b>	
Product type designation	Type B1
HW functional status	FS10 and higher
<b>Supply voltage</b>	
Rated value (DC)	See manual
<ul style="list-style-type: none"> <li>• For P1 and P2 bus</li> <li>• For AUX bus</li> <li>• for process terminals</li> </ul>	24 V 24 V; Equal potential group to P1/P2 bus or PE 24 V
Rated value (AC)	See manual
<ul style="list-style-type: none"> <li>• For P1 and P2 bus</li> <li>• For AUX bus</li> <li>• for process terminals</li> </ul>	230 V 230 V; Equal potential group to P1/P2 bus or PE 230 V
external protection for power supply lines	Yes
<b>Mains filter</b>	

## 4.11 BU type B1, dark-colored version, without AUX terminals, supply over supply terminals

<b>Article number</b>	<b>6ES7193-6BP20-0BB1</b>
<ul style="list-style-type: none"> <li>integrated</li> </ul>	No
<b>Current carrying capacity</b>	
up to 60 °C, max.	10 A
For P1 and P2 bus, max.	10 A
For AUX bus, max.	10 A
For process terminals, max.	5 A
<b>Hardware configuration</b>	
Automatic encoding	Yes
<b>Potential separation</b>	
between backplane bus and supply voltage	Yes
between process terminals and supply voltage	Yes; Not applicable for process terminals 9 to 12
between power bus and supply voltage	Yes
<b>Isolation</b>	
Isolation tested with	3 100 V DC
<b>Ambient conditions</b>	
<b>Ambient temperature during operation</b>	
<ul style="list-style-type: none"> <li>horizontal installation, min.</li> </ul>	-30 °C
<ul style="list-style-type: none"> <li>horizontal installation, max.</li> </ul>	60 °C
<ul style="list-style-type: none"> <li>vertical installation, min.</li> </ul>	-30 °C
<ul style="list-style-type: none"> <li>vertical installation, max.</li> </ul>	50 °C
<b>Altitude during operation relating to sea level</b>	
<ul style="list-style-type: none"> <li>Installation altitude above sea level, max.</li> </ul>	2 000 m; On request: Installation altitudes greater than 2 000 m
<b>Connection method</b>	
<b>Terminals</b>	
<ul style="list-style-type: none"> <li>Terminal type</li> </ul>	Push-in terminal
<ul style="list-style-type: none"> <li>Conductor cross-section, min.</li> </ul>	0.14 mm <sup>2</sup> ; AWG 26
<ul style="list-style-type: none"> <li>Conductor cross-section, max.</li> </ul>	2.5 mm <sup>2</sup> ; AWG 14
<ul style="list-style-type: none"> <li>Number of process terminals to I/O module</li> </ul>	12; Pro slot
<ul style="list-style-type: none"> <li>Number of terminals to AUX bus</li> </ul>	0
<ul style="list-style-type: none"> <li>Number of add-on terminals</li> </ul>	0
<ul style="list-style-type: none"> <li>Number of terminals with connection to P1 and P2 bus</li> </ul>	0; Pro slot
<b>Dimensions</b>	
Width	20 mm
Height	117 mm
Depth	35 mm
<b>Weights</b>	
Weight, approx.	48 g

## 4.12 BU type C0, light-colored version, with AUX terminals, supply over supply terminals

### Short designation

Short designation: BU20-P6+A2+4D

### 4.12.1 Product overview

#### Delivery options (packing unit VPE)

6ES7193-6BP20-0DC0 (VPE: 1 unit)

### View

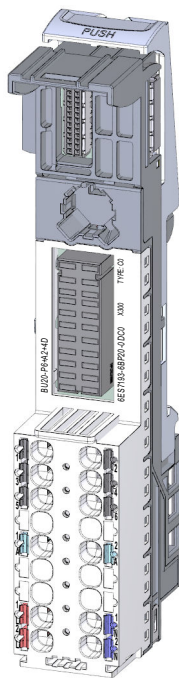

Figure 4-21 BU type C0, light-colored version, with AUX terminals, supply over supply terminals

### Properties

- BaseUnit suitable for all I/O modules of the BaseUnit type "C0/C1". Can be recognized by the laser inscription on the front and/or the last two digits of the article number.
  - Supply voltage (terminal 1 L, 2 / 1 N, 2 N): Max. 230 V AC/10 A
  - Current-carrying capacity per process terminal (terminal 1 to 4): Max. 5 A
  - Current carrying capacity per process terminal (terminal 5 and 6): Max. 10 A
- The BaseUnit opens up a new potential group by means of the inserted I/O module. The self-assembling voltage buses P1 and P2, and the AUX busbar are interrupted to the left-hand neighboring module (BaseUnit, interface module).
- Access to the AUX busbar via terminals

## 4.12 BU type C0, light-colored version, with AUX terminals, supply over supply terminals

- 6 terminals to the process (assignment with the I/O module)
- Two AUX terminals for connecting a PE terminal or potential. The AUX busbar is not connected to the I/O module. Max. 24 V DC/10 A
- Connection system in the form of push-in terminals You can find more information in the ET 200SP System Manual (<https://support.industry.siemens.com/cs/ww/en/view/58649293>).

**Maximum configuration per potential group**

The number of I/O modules that can be used per potential group depends on the following factors:

1. Total power requirement of all I/O modules operated on this potential group
2. Total power requirement of all loads connected externally to this potential group

The total current calculated according to item 1. and item 2. must not exceed 10 A.

**4.12.2 Connecting****Pin assignment**

Pin assignment for BU type C0, light-colored version, with AUX terminals, supply over supply terminals	
Terminal	Descriptions
1 to 6	Assignment is determined by the I/O module. You can find additional information in the I/O Module ( <a href="http://support.automation.siemens.com/WW/view/en/55679691/133300">http://support.automation.siemens.com/WW/view/en/55679691/133300</a> ) manual.
1 A, 2 A, AUX	Protective conductor connection or voltage bus, freely usable up to 230 V AC/DC with max. 10 A. If you connect a voltage, this voltage must belong to the same potential group as the rated supply voltage.
1 L, 2 L, (P1) / 1 N, 2 N, (P2)	1 L, 2 L: Rated supply voltage up to 230 V AC with max. 10 A 1 N, 2 N: Neutral/Ground

**Block diagram**

4.12 BU type C0, light-colored version, with AUX terminals, supply over supply terminals

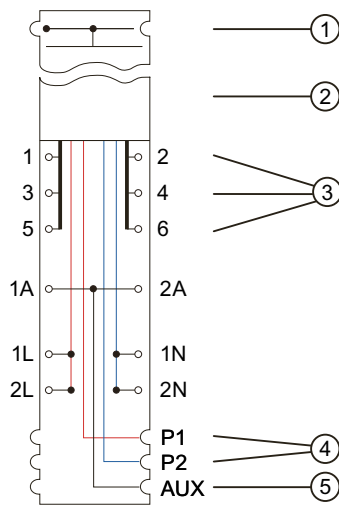

- ① Backplane bus
- ② I/O module
- ③ Terminals with connection to the I/O module
- ④ System-integrated, self-assembling voltage buses P1, P2 with connection to the infeed terminals (through the inserted I/O module). Interrupted to the adjacent module on the left, forms a new potential group
- ⑤ System-integrated, self-assembling AUX voltage bus with connection to the AUX terminals, interrupted to the adjacent module on the left, forms a new potential group

Figure 4-22. Block diagram of the BU type C0, light-colored version, with AUX terminals, supply over supply terminals

### 4.12.3 Technical specifications

#### Technical specifications of the BU type C0, light-colored version, with AUX terminals, supply over infeed terminals

Article number	6ES7193-6BP20-0DC0
<b>General information</b>	
Product type designation	ET 200SP, BaseUnit BU type C0, PU 1
HW functional status	FS10 and higher
<b>Supply voltage</b>	
Rated value (DC)	See manual
<ul style="list-style-type: none"> <li>• For P1 and P2 bus</li> <li>• For AUX bus</li> <li>• for process terminals</li> </ul>	24 V 24 V; Equal potential group to P1/P2 bus or PE 24 V
Rated value (AC)	See manual
<ul style="list-style-type: none"> <li>• For P1 and P2 bus</li> <li>• For AUX bus</li> <li>• for process terminals</li> </ul>	230 V 230 V; Equal potential group to P1/P2 bus or PE 230 V



## 4.12 BU type C0, light-colored version, with AUX terminals, supply over supply terminals

Article number	6ES7193-6BP20-0DC0
external protection for power supply lines	Yes; 10 A miniature circuit breaker with type B or C tripping characteristic for the respective rated supply voltage
<b>Mains filter</b>	
<ul style="list-style-type: none"> <li>integrated</li> </ul>	No
<b>Current carrying capacity</b>	
up to 60 °C, max.	10 A
For P1 and P2 bus, max.	10 A
For AUX bus, max.	10 A
For process terminals, max.	5 A; 10 A for process terminals 5 and 6
<b>Hardware configuration</b>	
Automatic encoding	Yes
<b>Potential separation</b>	
between backplane bus and supply voltage	Yes
between process terminals and supply voltage	Yes
between power bus and supply voltage	No
<b>Isolation</b>	
Isolation tested with	3 100 V DC
<b>Ambient conditions</b>	
<b>Ambient temperature during operation</b>	
<ul style="list-style-type: none"> <li>horizontal installation, min.</li> </ul>	-30 °C
<ul style="list-style-type: none"> <li>horizontal installation, max.</li> </ul>	60 °C
<ul style="list-style-type: none"> <li>vertical installation, min.</li> </ul>	-30 °C
<ul style="list-style-type: none"> <li>vertical installation, max.</li> </ul>	50 °C
<b>Altitude during operation relating to sea level</b>	
<ul style="list-style-type: none"> <li>Installation altitude above sea level, max.</li> </ul>	2 000 m; On request: Installation altitudes greater than 2 000 m
<b>Accessories</b>	
<b>Color coding labels</b>	
<ul style="list-style-type: none"> <li>for process terminals</li> </ul>	CC51, CC52
<ul style="list-style-type: none"> <li>for AUX terminals</li> </ul>	CC84 to CC86
<ul style="list-style-type: none"> <li>for add-on terminals</li> </ul>	does not exist
<b>Connection method</b>	
<b>Terminals</b>	
<ul style="list-style-type: none"> <li>Terminal type</li> </ul>	Push-in terminal
<ul style="list-style-type: none"> <li>Conductor cross-section, min.</li> </ul>	0.14 mm <sup>2</sup> ; AWG 26
<ul style="list-style-type: none"> <li>Conductor cross-section, max.</li> </ul>	2.5 mm <sup>2</sup> ; AWG 14
<ul style="list-style-type: none"> <li>Number of process terminals to I/O module</li> </ul>	12; Pro slot
<ul style="list-style-type: none"> <li>Number of terminals to AUX bus</li> </ul>	0
<ul style="list-style-type: none"> <li>Number of add-on terminals</li> </ul>	0

4.13 BU type C1, dark-colored version, with AUX terminals, supply over P1, P2 busbar

<b>Article number</b>	<b>6ES7193-6BP20-0DC0</b>
<ul style="list-style-type: none"> <li>Number of terminals with connection to P1 and P2 bus</li> </ul>	0; Pro slot
<b>Dimensions</b>	
Width	20 mm
Height	117 mm
Depth	35 mm
<b>Weights</b>	
Weight, approx.	47 g

### 4.13 BU type C1, dark-colored version, with AUX terminals, supply over P1, P2 busbar

**Short designation**

Short designation: BU20-P6+A2+4B

#### 4.13.1 Product overview

**Delivery options (packing unit VPE)**

6ES7193-6BP20-0BC1 (VPE: 1 unit)

**View**

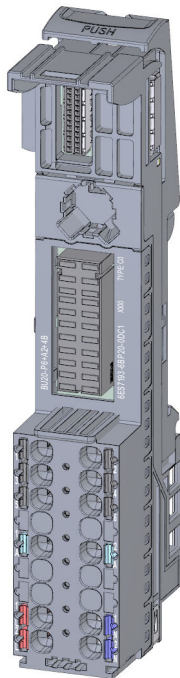

Figure 4-23 BU type C1, dark-colored version, with AUX terminals, supply over P1, P2 busbar

## 4.13 BU type C1, dark-colored version, with AUX terminals, supply over P1, P2 busbar

## Properties

- BaseUnit suitable for all I/O modules of the BaseUnit type "C0/C1". Can be recognized by the laser inscription on the front and/or the last two digits of the article number.
  - Current-carrying capacity per process terminal (terminal 1 to 4): Max. 5 A
  - Current carrying capacity per process terminal (terminal 5 and 6): Max. 10 A
- The BaseUnit further conducts the potential group. The self-assembling voltage buses P1 and P2, and the AUX busbar are connected to the left-hand neighboring module (BaseUnit).
- Access to the AUX busbar via terminals
- 6 terminals to the process (assignment with the I/O module)
- Two AUX terminals for connecting a PE terminal or potential. The AUX busbar is not connected to the I/O module. Max. 24 V DC/10 A
- Connection system in the form of push-in terminals Connection cross-sections are available in the ET 200SP System Manual (<https://support.industry.siemens.com/cs/ww/en/view/58649293>).

## 4.13.2 Connecting

## Pin assignment

Pin assignment for BU type C1, dark-colored version, with AUX terminals, supply over P1, P2 busbar	
Terminal	Descriptions
1 to 6	Assignment is determined by the I/O module. You can find additional information in the I/O Module ( <a href="http://support.automation.siemens.com/WW/view/en/55679691/133300">http://support.automation.siemens.com/WW/view/en/55679691/133300</a> ) manual.
1 A, 2 A, AUX	Protective conductor connection or voltage bus, freely usable up to 230 V AC/DC with max. 10 A. If you connect a voltage, this voltage must belong to the same potential group as the rated supply voltage.
1 L, 2 L, (P1) / 1 N, 2 N, (P2)	1 L, 2 L: Rated supply voltage up to 230 V AC with max. 10 A 1 N, 2 N: Neutral/Ground

**Block diagram**

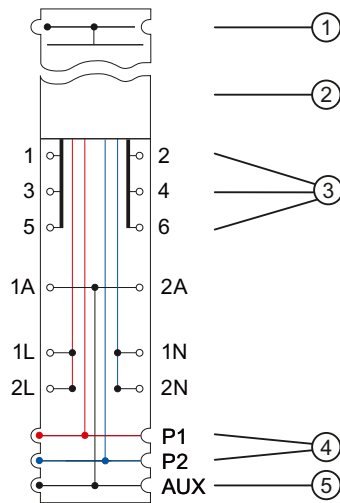

- ① Backplane bus
- ② Power module
- ③ Terminals with connection to the I/O module
- ④ System-integrated, self-assembling voltage buses P1, P2 with connection to the infeed terminals (through the inserted I/O module). Connected to the adjacent module on the left
- ⑤ System-integrated, self-assembling AUX voltage bus with connection to the AUX terminals, connected to the adjacent module on the left

Figure 4-24 Block diagram of the BU type C1, dark-colored version, with AUX terminals, supply over P1, P2 busbar

**4.13.3 Technical specifications**

**Technical specifications of the BU type C1, dark-colored version, with AUX terminals, supply over P1, P2 busbar**

<b>Article number</b>	<b>6ES7193-6BP20-0BC1</b>
<b>General information</b>	
Product type designation	Type C1
HW functional status	FS10 and higher
<b>Supply voltage</b>	
Rated value (DC)	See manual
• For P1 and P2 bus	24 V
• For AUX bus	24 V; Equal potential group to P1/P2 bus or PE
• for process terminals	24 V
Rated value (AC)	See manual
• For P1 and P2 bus	230 V
• For AUX bus	230 V; Equal potential group to P1/P2 bus or PE
• for process terminals	230 V
<b>Mains filter</b>	

## 4.13 BU type C1, dark-colored version, with AUX terminals, supply over P1, P2 busbar

<b>Article number</b>	<b>6ES7193-6BP20-0BC1</b>
<ul style="list-style-type: none"> <li>integrated</li> </ul>	No
<b>Current carrying capacity</b>	
up to 60 °C, max.	10 A
For P1 and P2 bus, max.	10 A
For AUX bus, max.	10 A
For process terminals, max.	5 A; 10 A for process terminals 5 and 6
<b>Hardware configuration</b>	
Automatic encoding	Yes
<b>Potential separation</b>	
between backplane bus and supply voltage	Yes
between process terminals and supply voltage	Yes
between power bus and supply voltage	No
<b>Isolation</b>	
Isolation tested with	3 100 V DC
<b>Ambient conditions</b>	
<b>Ambient temperature during operation</b>	
<ul style="list-style-type: none"> <li>horizontal installation, min.</li> </ul>	-30 °C
<ul style="list-style-type: none"> <li>horizontal installation, max.</li> </ul>	60 °C
<ul style="list-style-type: none"> <li>vertical installation, min.</li> </ul>	-30 °C
<ul style="list-style-type: none"> <li>vertical installation, max.</li> </ul>	50 °C
<b>Altitude during operation relating to sea level</b>	
<ul style="list-style-type: none"> <li>Installation altitude above sea level, max.</li> </ul>	2 000 m; On request: Installation altitudes greater than 2 000 m
<b>Accessories</b>	
<b>Color coding labels</b>	
<ul style="list-style-type: none"> <li>for process terminals</li> </ul>	CC51
<ul style="list-style-type: none"> <li>for AUX terminals</li> </ul>	CC84 to CC86
<ul style="list-style-type: none"> <li>for add-on terminals</li> </ul>	does not exist
<b>Connection method</b>	
<b>Terminals</b>	
<ul style="list-style-type: none"> <li>Terminal type</li> </ul>	Push-in terminal
<ul style="list-style-type: none"> <li>Conductor cross-section, min.</li> </ul>	0.14 mm <sup>2</sup> ; AWG 26
<ul style="list-style-type: none"> <li>Conductor cross-section, max.</li> </ul>	2.5 mm <sup>2</sup> ; AWG 14
<ul style="list-style-type: none"> <li>Number of process terminals to I/O module</li> </ul>	16; Pro slot
<ul style="list-style-type: none"> <li>Number of terminals to AUX bus</li> </ul>	0
<ul style="list-style-type: none"> <li>Number of add-on terminals</li> </ul>	0
<ul style="list-style-type: none"> <li>Number of terminals with connection to P1 and P2 bus</li> </ul>	2; Pro slot
<b>Dimensions</b>	
Width	20 mm

4.14 BU type D0, dark-colored version, without AUX terminals, supply over supply terminals

<b>Article number</b>	<b>6ES7193-6BP20-0BC1</b>
Height	117 mm
Depth	35 mm
<b>Weights</b>	
Weight, approx.	47 g

## 4.14 BU type D0, dark-colored version, without AUX terminals, supply over supply terminals

### Short designation

Short designation: BU20-P12+A0+0B

### 4.14.1 Product overview

#### Delivery options (packing unit VPE)

6ES7193-6BP00-0BD0 (VPE: 1 unit)

#### View

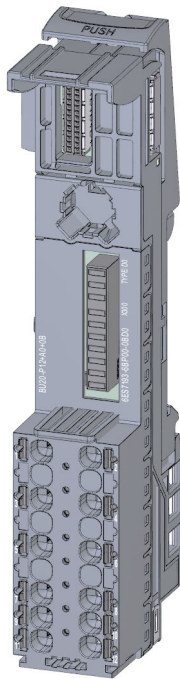

Figure 4-25 BU type D0, dark-colored version, without AUX terminals, supply over supply terminals

## 4.14 BU type D0, dark-colored version, without AUX terminals, supply over supply terminals

**Properties**

- BaseUnit suitable for all I/O modules of the BaseUnit type "D0". Can be recognized by the laser inscription on the front and/or the last two digits of the article number.
  - Current-carrying capacity per process terminal (terminal 1 to 12): Max. 5 A
- The BaseUnit further conducts the potential group. The self-assembling voltage buses P1 and P2, and the AUX busbar are connected to the left-hand neighboring module (BaseUnit).
- No access to the power and AUX busbars via terminals
- 12 terminals to the process (assignment with the I/O module)
- Connection system in the form of push-in terminals Connection cross-sections are available in the ET 200SP System Manual (<https://support.industry.siemens.com/cs/ww/en/view/58649293>).

**NOTE**

The shield connection (shield support and shield terminal) is not intended for BaseUnit BU20-P12+A0+0B and must not be installed.

**4.14.2 Connecting****Pin assignment**

Pin assignment for BU type D0, dark-colored version, without AUX terminals, supply over supply terminals	
Terminal	Descriptions
1 to 12	Assignment is determined by the I/O module. You can find additional information in the I/O Module manual. ( <a href="http://support.automation.siemens.com/WW/view/en/55679691/133300">http://support.automation.siemens.com/WW/view/en/55679691/133300</a> )
(AUX)	No access to the AUX busbar via terminals

**Block diagram**

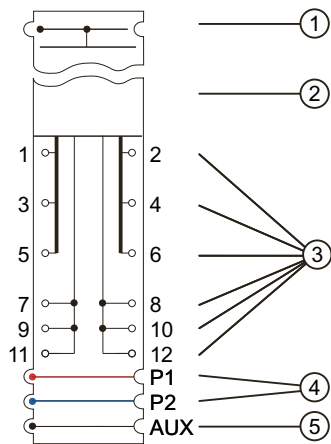

- ① Backplane bus
- ② I/O module
- ③ Terminals with connection to the I/O module
- ④ System-integrated, self-assembling voltage buses P1, P2 without connection to the terminals, connected to the adjacent module on the left
- ⑤ System-integrated, self-assembling AUX voltage bus without connection to the AUX terminals, connected to the adjacent module on the left

Figure 4-26 Block diagram of the BU type D0, dark-colored version, without AUX terminals, supply over supply terminals

**4.14.3 Technical specifications**

**Technical specifications of the BU type D0, dark-colored version, without AUX terminals, supply over infeed terminals**

<b>Article number</b>	<b>6ES7193-6BP00-0BD0</b>
<b>General information</b>	
Product type designation	ET 200SP, BaseUnit BU type D0, PU 1
HW functional status	FS10 and higher
<b>Supply voltage</b>	
Rated value (AC)	See manual
<ul style="list-style-type: none"> <li>• For P1 and P2 bus</li> <li>• For AUX bus</li> <li>• for process terminals</li> </ul>	277 V 277 V; Equal potential group to P1/P2 bus or PE 277 V; 480 V (L1 - L2 - L3); 277 V (L, N)
<b>Mains filter</b>	
<ul style="list-style-type: none"> <li>• integrated</li> </ul>	Yes; Between N and FE
<b>Current carrying capacity</b>	
up to 60 °C, max.	5 A
For P1 and P2 bus, max.	10 A
For AUX bus, max.	10 A
For process terminals, max.	5 A



## 4.14 BU type D0, dark-colored version, without AUX terminals, supply over supply terminals

<b>Article number</b>	<b>6ES7193-6BP00-0BD0</b>
<b>Hardware configuration</b>	
Automatic encoding	Yes
<b>Formation of potential groups</b>	
• New potential group	No
• Potential group continued from the left	Yes
<b>Potential separation</b>	
between backplane bus and supply voltage	Yes
between power bus and supply voltage	Yes
<b>Isolation</b>	
Isolation tested with	3 100 V DC
<b>Ambient conditions</b>	
<b>Ambient temperature during operation</b>	
• horizontal installation, min.	-30 °C
• horizontal installation, max.	60 °C
• vertical installation, min.	-30 °C
• vertical installation, max.	50 °C
<b>Altitude during operation relating to sea level</b>	
• Installation altitude above sea level, max.	2 000 m; On request: Installation altitudes greater than 2 000 m
<b>Accessories</b>	
<b>Color coding labels</b>	
• for process terminals	does not exist
• for AUX terminals	does not exist
• for add-on terminals	does not exist
<b>Connection method</b>	
<b>Terminals</b>	
• Terminal type	Push-in terminal
• Conductor cross-section, min.	0.14 mm <sup>2</sup> ; AWG 26
• Conductor cross-section, max.	2.5 mm <sup>2</sup> ; AWG 14
• Number of process terminals to I/O module	12; Pro slot
• Number of terminals to AUX bus	0
• Number of add-on terminals	0
• Number of terminals with connection to P1 and P2 bus	0; Pro slot
<b>Dimensions</b>	
Width	20 mm
Height	117 mm
Depth	35 mm
<b>Weights</b>	
Weight, approx.	47 g

## 4.15 BU type F0, dark-colored version, with AUX terminals, supply over supply terminals

### Short designation

Short designation: BU20-P8+A4+0B

### 4.15.1 Product overview

When you use the AUX terminals as a PE busbar:

#### NOTICE

When AUX is used as PE, AUX must be identified as green-yellow (e.g., gn/ye color-coded labels). These identifications must be removed if the terminals are no longer used as PE.

### Delivery options (packing unit VPE)

6ES7193-6BP20-0BF0 (VPE: 1 unit)

### View

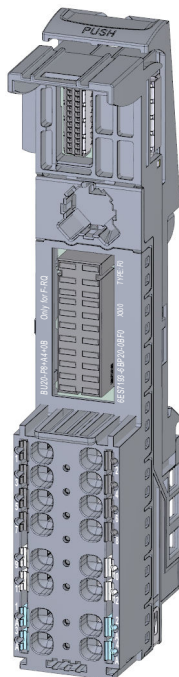

Figure 4-27 BU type F0, dark-colored version, with AUX terminals, supply over supply terminals

## 4.15 BU type F0, dark-colored version, with AUX terminals, supply over supply terminals

## Properties

- BaseUnit suitable for all I/O modules of the BaseUnit type "F0". Can be recognized by the laser inscription on the front and/or the last two digits of the article number.
  - Current carrying capacity per process terminal (terminals 1 to 4 and 9 to 12): Max. 5 A
- The BaseUnit loops the potential group through with the self-assembling voltage buses P1, P2 and the AUX bus of the left-hand neighboring module (BaseUnit).
- Access to the AUX busbar via terminals 1 A to 4 A max. 24 V DC/10 A
- 8 terminals to the process (occupied by the I/O module)
- Connection system in the form of push-in terminals Connection cross-sections are available in the ET 200SP System Manual (<https://support.industry.siemens.com/cs/ww/en/view/58649293>).

## 4.15.2 Connecting up

## Pin assignment

Pin assignment for BU type F0, dark-colored version, with AUX terminals, supply over supply terminals		
Terminals of a potential group	Fail-safe module Overvoltage category 3	Non-fail-safe module Overvoltage category 2
1 to 4	Up to 230 V AC/DC (AC only one phase) Assignment is determined by the I/O module. You can find additional information in the I/O Module ( <a href="http://support.automation.siemens.com/WW/view/en/55679691/133300">http://support.automation.siemens.com/WW/view/en/55679691/133300</a> ) manual.	
9 to 12	Safe extra low voltage SELV/PELV Assignment is determined by the I/O module. You can find additional information in the I/O Module ( <a href="http://support.automation.siemens.com/WW/view/en/55679691/133300">http://support.automation.siemens.com/WW/view/en/55679691/133300</a> ) manual.	
P1, P2, AUX (1 A to 4 A)	SELV/PELV (max. 10 A)	SELV/PELV or up to 230 V AC/DC (AC only one phase) (max. 10 A)

Use the AUX terminals only with an identical voltage or PE associated with the supply voltage.

**Block diagram**

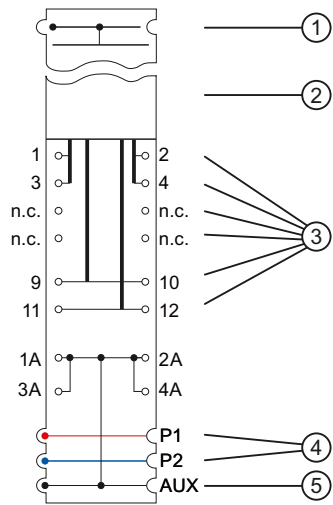

- ① Backplane bus
- ② I/O module
- ③ Terminals with connection to the I/O module
- ④ System-integrated, self-assembling voltage buses P1, P2 without connection to the terminals, connected to the adjacent module on the left
- ⑤ System-integrated, self-assembling AUX voltage bus with connection to the AUX terminals, connected to the adjacent module on the left

Figure 4-28 Block diagram of the BU type F0, dark-colored version, with AUX terminals, supply over supply terminals

**4.15.3 Technical specifications**

**Technical specifications of the BU type F0, dark-colored version, with AUX terminals, supply over infeed terminals**

<b>Article number</b>	<b>6ES7193-6BP20-0BF0</b>
<b>General information</b>	
Product type designation	ET 200SP, BaseUnit BU type F0, BU20-P8+A4+0B, PU 1
HW functional status	FS10 and higher
<b>Supply voltage</b>	
Rated value (DC)	See manual
Rated value (AC)	See manual
<b>Mains filter</b>	
<ul style="list-style-type: none"> <li>• integrated</li> </ul>	No
<b>Current carrying capacity</b>	
up to 60 °C, max.	10 A
For P1 and P2 bus, max.	10 A
For AUX bus, max.	10 A
For process terminals, max.	5 A

<b>Article number</b>	<b>6ES7193-6BP20-0BF0</b>
<b>Hardware configuration</b>	
Automatic encoding	Yes
<b>Potential separation</b>	
between backplane bus and supply voltage	Yes
between process terminals and supply voltage	Yes
between power bus and supply voltage	Yes
<b>Isolation</b>	
Isolation tested with	3 100 V DC
<b>Ambient conditions</b>	
<b>Ambient temperature during operation</b>	
• horizontal installation, min.	-30 °C
• horizontal installation, max.	60 °C
• vertical installation, min.	-30 °C
• vertical installation, max.	50 °C
<b>Altitude during operation relating to sea level</b>	
• Installation altitude above sea level, max.	2 000 m; On request: Installation altitudes greater than 2 000 m
<b>Dimensions</b>	
Width	20 mm
Height	117 mm
Depth	35 mm
<b>Weights</b>	
Weight, approx.	48 g

## 4.16 BU type U0, light-colored version without AUX terminals

### Short designation

Short designation: BU20-P16+A0+2D

### 4.16.1 Product overview

#### Delivery options (packing unit VPE)

6ES7193-6BP00-0DU0 (VPE: 1 unit)

6ES7193-6BP00-2DU0 (VPE: 10 units)

## View

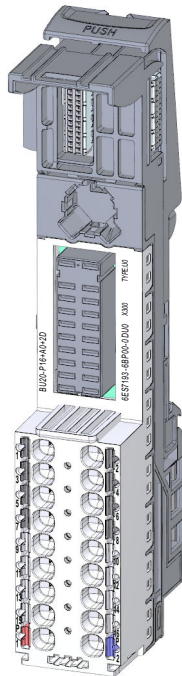

Figure 4-29 BU type U0, light-colored version without AUX terminals

## Properties

- BaseUnit suitable for all I/O modules of the BaseUnit type "U0". Can be recognized by the laser inscription on the front and/or the last two digits of the article number.
  - Current-carrying capacity per process terminal (terminal 1 to 16): Max. 10 A
- The BaseUnit opens up a new potential group. The self-assembling voltage buses P1, P2 and the AUX busbar are disconnected from the adjacent module on the left (BaseUnit, interface module, CPU).
- No access to the AUX busbar via terminals
- 16 terminals to the process (assignment through the I/O module)
- Connection system in the form of push-in terminals Connection cross-sections are available in the ET 200SP System Manual (<https://support.industry.siemens.com/cs/ww/en/view/58649293>).

## Maximum configuration per potential group

The number of I/O modules that can be used per potential group depends on the following factors:

1. Total power requirement of all I/O modules operated on this potential group
2. Total power requirement of all loads connected externally to this potential group

The total current calculated according to item 1. and item 2. must not exceed 10 A.

---

### NOTE

A potential group opened with light-colored BaseUnit of type U0 must not contain a dark-colored BaseUnit of type A0 or A1.

---

## 4.16.2 Connection

### Pin assignment

Pin assignment for BU type U0, light-colored version, without AUX terminals	
Terminal	Descriptions
1 to 16	Assignment is determined by the I/O module. You can find additional information in the I/O Module manual. ( <a href="http://support.automation.siemens.com/WW/view/de/55679691/133300">http://support.automation.siemens.com/WW/view/de/55679691/133300</a> )
(AUX)	No access to the AUX busbar via terminals
P1 / P2	P1: Rated supply voltage up to 230 V AC with max. 10 A P2: Neutral/Ground

### Block diagram

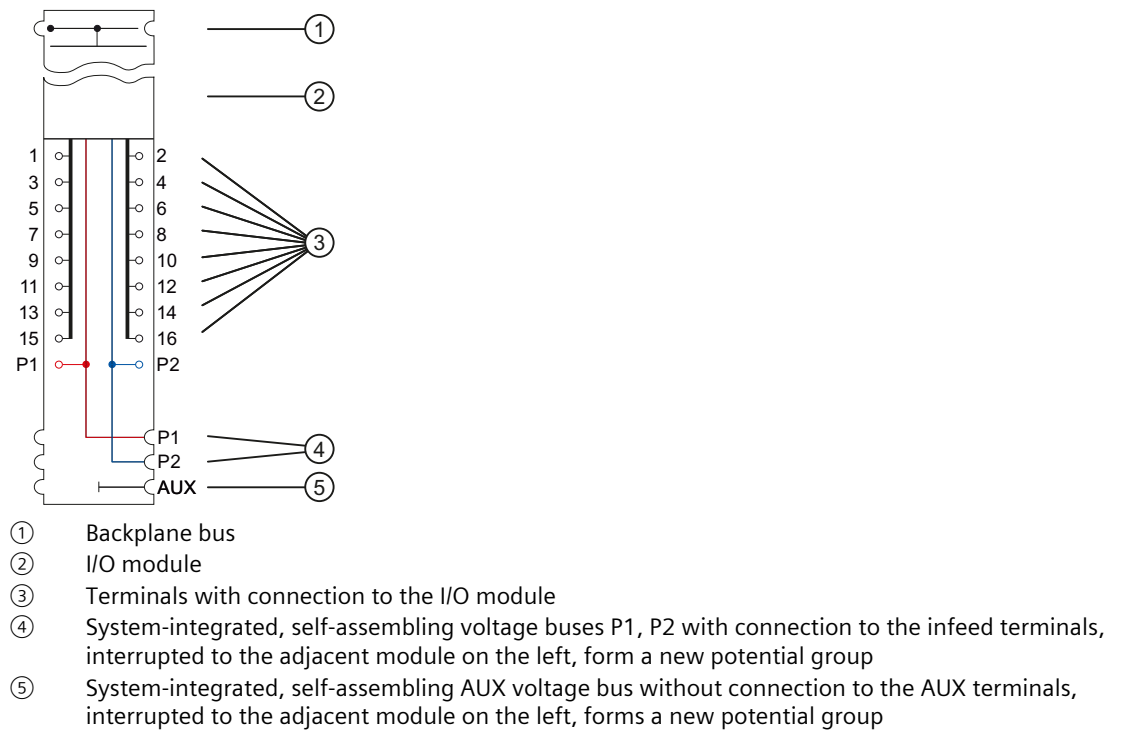

Figure 4-30 Block diagram of the BU type U0, light-colored version, without AUX terminals

## 4.16.3 Technical specifications

### Technical specifications of the BU type U0, light-colored version, without AUX terminals

Article number	6ES7193-6BP00-0DU0
General information	
Product type designation	BU type U0, BU20-P16+A0+2D, PU 1

## 4.16 BU type U0, light-colored version without AUX terminals

<b>Article number</b>	<b>6ES7193-6BP00-0DU0</b>
HW functional status	FS10 and higher
<b>Supply voltage</b>	
Rated value (DC)	See manual
<ul style="list-style-type: none"> <li>For P1 and P2 bus</li> </ul>	120 V
<ul style="list-style-type: none"> <li>For AUX bus</li> </ul>	120 V; Equal potential group to P1/P2 bus or PE
<ul style="list-style-type: none"> <li>for process terminals</li> </ul>	120 V
Rated value (AC)	See manual
<ul style="list-style-type: none"> <li>For P1 and P2 bus</li> </ul>	240 V
<ul style="list-style-type: none"> <li>For AUX bus</li> </ul>	240 V; Equal potential group to P1/P2 bus or PE
<ul style="list-style-type: none"> <li>for process terminals</li> </ul>	240 V
external protection for power supply lines	Yes
<b>Mains filter</b>	
<ul style="list-style-type: none"> <li>integrated</li> </ul>	No
<b>Current carrying capacity</b>	
up to 60 °C, max.	10 A
For P1 and P2 bus, max.	10 A
For AUX bus, max.	10 A
For process terminals, max.	10 A; Point of contact, derating depends on the module
<b>Hardware configuration</b>	
Automatic encoding	Yes
<b>Formation of potential groups</b>	
<ul style="list-style-type: none"> <li>New potential group</li> </ul>	Yes
<ul style="list-style-type: none"> <li>Potential group continued from the left</li> </ul>	No
<b>Potential separation</b>	
between backplane bus and supply voltage	Yes
between process terminals and supply voltage	Yes; Not applicable for process terminals 15 and 16
between power bus and supply voltage	No
<b>Isolation</b>	
Isolation tested with	3 100 V DC
<b>Ambient conditions</b>	
<b>Ambient temperature during operation</b>	
<ul style="list-style-type: none"> <li>horizontal installation, min.</li> </ul>	-30 °C
<ul style="list-style-type: none"> <li>horizontal installation, max.</li> </ul>	60 °C
<ul style="list-style-type: none"> <li>vertical installation, min.</li> </ul>	-30 °C
<ul style="list-style-type: none"> <li>vertical installation, max.</li> </ul>	50 °C
<b>Altitude during operation relating to sea level</b>	
<ul style="list-style-type: none"> <li>Installation altitude above sea level, max.</li> </ul>	2 000 m; On request: Installation altitudes greater than 2 000 m
<b>Connection method</b>	



<b>Article number</b>	<b>6ES7193-6BP00-0DU0</b>
<b>Terminals</b>	
<ul style="list-style-type: none"> <li>Terminal type</li> <li>Conductor cross-section, min.</li> <li>Conductor cross-section, max.</li> <li>Number of process terminals to I/O module</li> <li>Number of terminals to AUX bus</li> <li>Number of add-on terminals</li> <li>Number of terminals with connection to P1 and P2 bus</li> </ul>	Push-in terminal 0.14 mm <sup>2</sup> ; 0.2 mm <sup>2</sup> without wire end ferrule 2.5 mm <sup>2</sup> ; 1.5 mm <sup>2</sup> with wire end ferrule 16 0 0 2
<b>Dimensions</b>	
Width	20 mm
Height	117 mm
Depth	35 mm
<b>Weights</b>	
Weight, approx.	50 g

## 4.17 BU type U0, dark-colored version, without AUX terminals

### Short designation

Short designation: BU20-P16+A0+2B

### 4.17.1 Product overview

#### Delivery options (packing unit VPE)

6ES7193-6BP00-0BU0 (VPE: 1 unit)  
 6ES7193-6BP00-2BU0 (VPE: 10 units)

## View

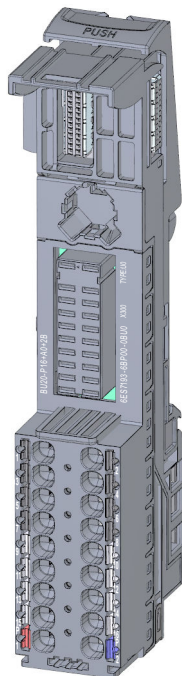

Figure 4-31 BU type U0, dark-colored version, without AUX terminals

## Properties

- BaseUnit suitable for all I/O modules of the BaseUnit type "U0". Can be recognized by the laser inscription on the front and/or the last two digits of the article number.
  - Current-carrying capacity per process terminal (terminal 1 to 16): Max. 10 A
- The BaseUnit further conducts the potential group. The self-assembling voltage buses P1 and P2, and the AUX busbar are connected to the left-hand neighboring module (BaseUnit).
- No access to the AUX busbar via terminals
- 16 terminals to the process (assignment through the I/O module)
- Connection system in the form of push-in terminals Connection cross-sections are available in the ET 200SP System Manual (<https://support.industry.siemens.com/cs/ww/en/view/58649293>).

## 4.17.2 Connection

### Pin assignment

Pin assignment for BU type U0, dark-colored version, without AUX terminals	
Terminal	Descriptions
1 to 16	Assignment is determined by the I/O module. You can find additional information in the I/O Module manual. <a href="http://support.automation.siemens.com/WW/view/de/55679691/133300">http://support.automation.siemens.com/WW/view/de/55679691/133300</a>
(AUX)	No access to the AUX busbar via terminals
P1 / P2	P1: Rated supply voltage up to 230 V AC with max. 10 A P2: Neutral/Ground

### Block diagram

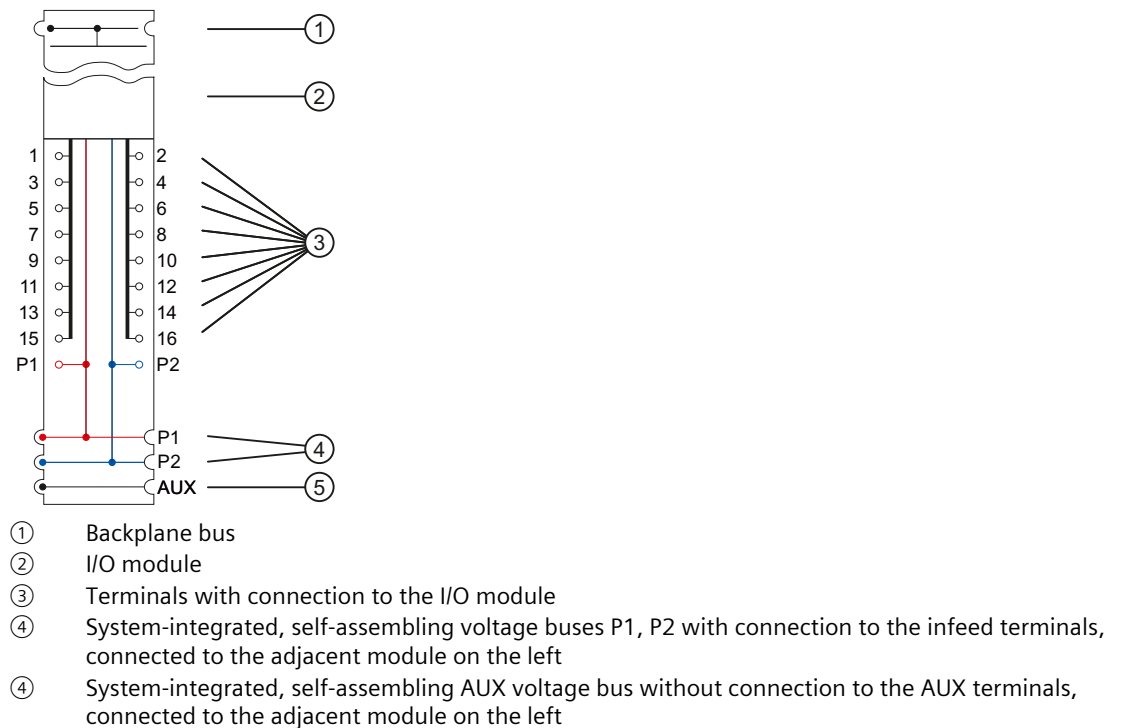

Figure 4-32 Block diagram of the BU type U0, dark-colored version, without AUX terminals

## 4.17.3 Technical specifications

### Technical specifications of the BU type U0, dark-colored version, without AUX terminals

Article number	6ES7193-6BP00-0BU0
<b>General information</b>	
Product type designation	BU type U0, BU20-P16+A0+2B, PU 1

## 4.17 BU type U0, dark-colored version, without AUX terminals

<b>Article number</b>	<b>6ES7193-6BP00-0BU0</b>
HW functional status	FS10 and higher
<b>Supply voltage</b>	
Rated value (DC)	See manual
<ul style="list-style-type: none"> <li>For P1 and P2 bus</li> </ul>	120 V
<ul style="list-style-type: none"> <li>For AUX bus</li> </ul>	120 V; Equal potential group to P1/P2 bus or PE
<ul style="list-style-type: none"> <li>for process terminals</li> </ul>	120 V
Rated value (AC)	See manual
<ul style="list-style-type: none"> <li>For P1 and P2 bus</li> </ul>	240 V
<ul style="list-style-type: none"> <li>For AUX bus</li> </ul>	240 V; Equal potential group to P1/P2 bus or PE
<ul style="list-style-type: none"> <li>for process terminals</li> </ul>	240 V
<b>Mains filter</b>	
<ul style="list-style-type: none"> <li>integrated</li> </ul>	No
<b>Current carrying capacity</b>	
up to 60 °C, max.	10 A
For P1 and P2 bus, max.	10 A
For AUX bus, max.	10 A
For process terminals, max.	10 A; Point of contact, derating depends on the module
<b>Hardware configuration</b>	
Automatic encoding	Yes
<b>Formation of potential groups</b>	
<ul style="list-style-type: none"> <li>New potential group</li> </ul>	No
<ul style="list-style-type: none"> <li>Potential group continued from the left</li> </ul>	Yes
<b>Potential separation</b>	
between backplane bus and supply voltage	Yes
between process terminals and supply voltage	Yes; Not applicable for process terminals 15 and 16
between power bus and supply voltage	No
<b>Isolation</b>	
Isolation tested with	3 100 V DC
<b>Ambient conditions</b>	
<b>Ambient temperature during operation</b>	
<ul style="list-style-type: none"> <li>horizontal installation, min.</li> </ul>	-30 °C
<ul style="list-style-type: none"> <li>horizontal installation, max.</li> </ul>	60 °C
<ul style="list-style-type: none"> <li>vertical installation, min.</li> </ul>	-30 °C
<ul style="list-style-type: none"> <li>vertical installation, max.</li> </ul>	50 °C
<b>Altitude during operation relating to sea level</b>	
<ul style="list-style-type: none"> <li>Installation altitude above sea level, max.</li> </ul>	2 000 m; On request: Installation altitudes greater than 2 000 m
<b>Connection method</b>	
<b>Terminals</b>	

Article number	6ES7193-6BP00-0BU0
<ul style="list-style-type: none"> <li>Terminal type</li> <li>Conductor cross-section, min.</li> <li>Conductor cross-section, max.</li> <li>Number of process terminals to I/O module</li> <li>Number of terminals to AUX bus</li> <li>Number of add-on terminals</li> <li>Number of terminals with connection to P1 and P2 bus</li> </ul>	Push-in terminal 0.14 mm <sup>2</sup> ; 0.2 mm <sup>2</sup> without wire end ferrule 2.5 mm <sup>2</sup> ; 1.5 mm <sup>2</sup> with wire end ferrule 16 0 0 2
Dimensions	
Width	20 mm
Height	117 mm
Depth	35 mm
Weights	
Weight, approx.	50 g

## BaseUnits for motor starters

### 5.1 Introduction

#### Properties of the infeed bus

- The infeed bus is set up by connecting the BaseUnits, and wiring takes place automatically
- The infeed bus distributes the energy to the SIMATIC ET 200SP motor starters within one load group
- The max. current carrying capacity is up to 32 A (3-phase)
  - With infeed (for one load group) and motor connection
  - Infeed bus: 3-pole + PE
  - The voltage range for power infeed is 48 V AC to 500 V AC

You must observe the deratings depending on the configuration.

#### Properties of the self-assembling voltage bus (power bus)

- Maximum current: 7 A
- Rated voltage: 24 V DC

You must observe the deratings depending on the configuration.

#### AUX1 bus

For BaseUnits BU30-MS7 to BU30-MS10, the AUX1 bus is used for routing the F-DI signal. This enables a group shutdown via the F-DI bus.

You can find assembly rules of the BaseUnits for the SIMATIC ET 200SP motor starter in the System Manual SIMATIC ET 200SP motor starters.

### 5.2 Safety-related shutdown

#### Single shutdown

With BaseUnits BU30-MS5 to BU30-MS6, a single shutdown can be implemented using the F-DI. The single shutdown in SIL3 Cat. 4 PLe is possible with fail-safe PP-switching or PM-switching control modules.

For single use of the BU30-MS7 and BU30-MS10, a fail-safe PP-switching control module must always be used.

#### Group shutdown

With BaseUnits BU30-MS7 to BU30-MS10, a group shutdown can be implemented using the F-DI.

The group shutdown in SIL3 Cat. 4 PLe is only possible with fail-safe PP-switching control modules. A group shutdown is also possible by a fail-safe shutdown of the supply voltage with all motor starter BaseUnits.

**⚠ WARNING**

**Safety-related shutdown using the F-DI**

Depending on the I/O used, the shutdown takes place via one or two output channels (terminals):

- PM-switching: The shutdown takes place via two output channels.
- PP-switching: The shutdown takes place via one output channel.

Shutdown via only one output channel (PP-switching) achieves SILCL 3 according to EN 62061, PL e / Cat. 4 according to EN ISO 13849-1, if it is ensured that the cabling is installed in a cross-circuit-proof/P-short-circuit-proof manner.

## 5.3 BU30-MS1 - BaseUnit with 24 V DC and 500 V AC infeed

### 5.3.1 Product overview

#### Article number

3RK1908-0AP00-0AP0

#### View



Figure 5-1 BaseUnit with 24 V DC and 500 V AC infeed

## Properties

- BaseUnit suitable for all fail-safe and non-fail-safe SIMATIC ET 200SP High Feature motor starters
- The BaseUnit opens a new potential group (24 V DC). The potential group (24 V DC) is interrupted to the adjacent module on the left (BaseUnit, interface module/CPU).
- The BaseUnit opens a new potential group (500 V AC). The infeed bus L1 (L), L2 (N), L3, PE is interrupted to the left-hand BaseUnit of the ET 200SP motor starter.
- Connection method using push-in terminals
- The touch protection cover for the infeed bus (3RK1908-1DA00-2BP0) is included in the scope of delivery.
- The F-DI of the fail-safe motor starter is connected internally to the potential group (24 V DC). When the supply voltage (24 V DC) is applied, the motor starter is ready for operation.
- Version for HA system available: 3RK1908-0AP00-0AHO

### Maximum configuration per voltage group (24 V DC)

The number of I/O modules that can be used per potential group depends on the following factors:

1. Total power requirement of all I/O modules operated on this potential group
2. Total power requirement of all loads connected externally to this potential group

The total current calculated according to item 1. and item 2. must not exceed 7 A.

### Maximum configuration of the infeed bus (500 V AC)

The number of motor starters that can be used per infeed group depends on the following factors:

1. Total current requirement of all motor starters operated on this infeed group.
2. Ambient temperature and installation type in which the motor starters are operated.  
You can find further information in the derating table in the Manual SIMATIC ET 200SP Motor Starter (<https://support.industry.siemens.com/cs/ww/en/view/109479973>).

## 5.3.2 Connection

### Pin assignment

Pin assignment for BaseUnit with 24 V DC and 500 V AC infeed	
Terminal	Descriptions
L1(L), L2(N), L3, PE	Power supply Assignment is determined by the motor starter. You can find more information in the ET 200SP Motor Starter ( <a href="https://support.industry.siemens.com/cs/ww/en/view/109479973">https://support.industry.siemens.com/cs/ww/en/view/109479973</a> ) manual.
T1, T2, T3, PE	Motor feeder
24 V DC, M	24 V DC: Supply voltage 24 V DC with max. 7 A M: Ground



## Block diagram

The figure below shows the block diagram of the BaseUnit with 24 V DC and 500 V AC infeed.

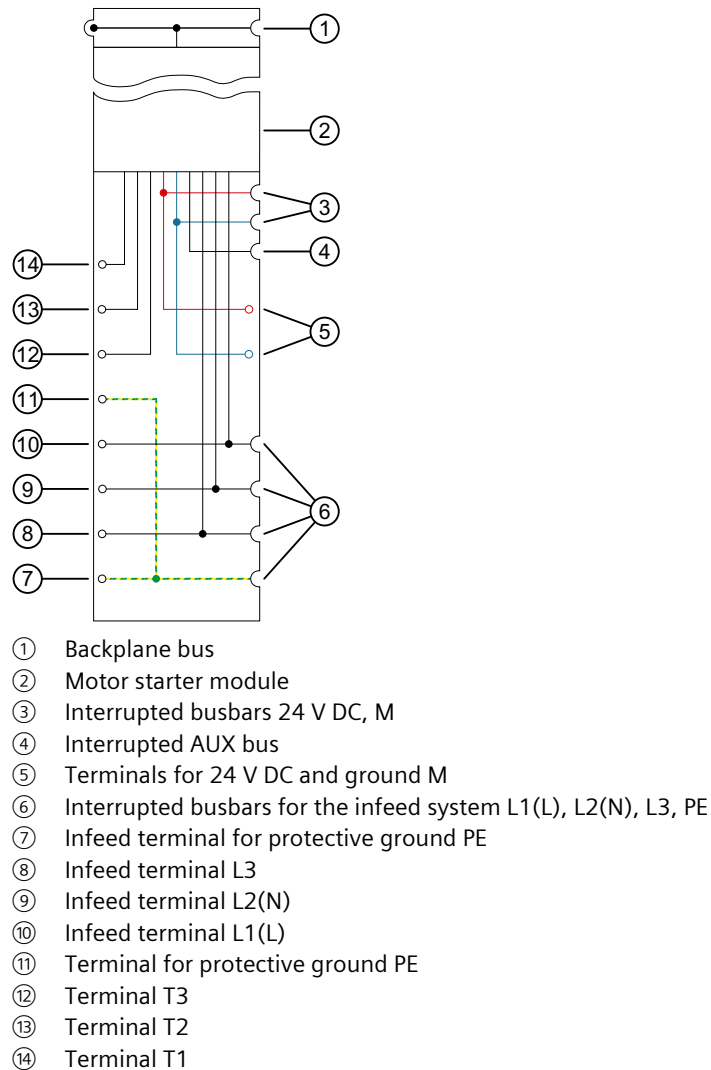

Figure 5-2 Block diagram BaseUnit with 24 V DC and 500 V AC infeed

### 5.3.3 Technical specifications

#### Technical specifications of the BaseUnit with 24 V DC and 500 V AC infeed

3RK1908-0AP00-0AP0	
Product type designation	BU30-MS1
Galvanic isolation	
Galvanic isolation between backplane bus and supply voltage	Yes
Insulation tested with	2500 V AC
Rated operating voltage	24 V DC

5.4 BU30-MS2 - BaseUnit with 500 V AC infeed

<b>3RK1908-0AP00-0APO</b>	
Max. operating current	7 A (observe derating <sup>1)</sup> )
Rated insulation voltage in accordance with IEC 60947-1	500 V
Impulse withstand voltage/rated value $U_{imp}$ according to IEC 60947-1	6 kV
Operating voltage range	48 V AC to 500 V AC
Max. current-carrying capacity	32 A (observe derating <sup>1)</sup> )
Isolating function between the infeed terminals L1(L), L2 (N), L3 and motor feeder terminals T1, T2, T3 for motor starters in parking position, or removed motor starters: impulse withstand voltage/rated value $U_{imp}$ according to IEC 60947-1	6 kV
Wiring	
Push-in	Required tools for releasing: Standard screwdriver size 1 (SZF1 - 0.6x3.5)
Dimensions	
Width	30 mm
Height	215 mm
Weights	
Weight, approx.	164 g

<sup>1)</sup> Derating table in SIMATIC ET 200SP Motor Starter manual (<https://support.industry.siemens.com/cs/ww/en/view/109479973>)

## 5.4 BU30-MS2 - BaseUnit with 500 V AC infeed

### 5.4.1 Product overview

#### Article number

3RK1908-0AP00-0CP0

## View



Figure 5-3 BaseUnit with 500 V AC infeed

## Properties

- BaseUnit suitable for all fail-safe and non-fail-safe SIMATIC ET 200SP High Feature motor starters
- The BaseUnit takes over the potential group (24 V DC) from the adjacent module on the left and loops this through.
- The BaseUnit opens a new potential group (500 V AC). The infeed bus L1 (L), L2 (N), L3, PE is interrupted to the left-hand BaseUnit of the ET 200SP motor starter.
- Connection method using push-in terminals
- The touch protection cover for the infeed bus (3RK1908-1DA00-2BP0) is included in the scope of delivery.
- The F-DI of the fail-safe motor starter is connected internally to the potential group (24 V DC). When the supply voltage (24 V DC) is applied, the motor starter is ready for operation.
- Version for HA system available: 3RK1908-0AP00-0CHO

## Maximum configuration of the infeed bus (500 V AC)

The number of motor starters that can be used per infeed group depends on the following factors:

1. Total current requirement of all motor starters operated on this infeed group.
2. Ambient temperature and installation type in which the motor starters are operated. You can find further information in the derating table in the Manual SIMATIC ET 200SP Motor Starter (<https://support.industry.siemens.com/cs/ww/en/view/109479973>).

## 5.4.2 Connection

### Pin assignment

Pin assignment for BaseUnit with 500 V AC infeed	
Terminal	Descriptions
L1(L), L2(N), L3, PE	Power supply Assignment is determined by the motor starter. See Manual ET 200SP motor starters ( <a href="https://support.industry.siemens.com/cs/ww/en/view/109479973">https://support.industry.siemens.com/cs/ww/en/view/109479973</a> ).
T1, T2, T3, PE	Motor feeder

### Block diagram

The figure below shows the block diagram of the BaseUnit with 500 V AC infeed.

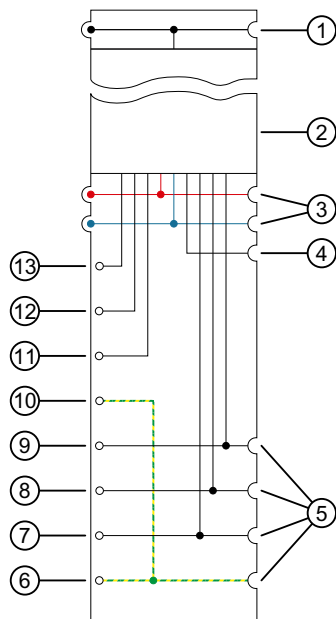

- ① Backplane bus
- ② Motor starter module
- ③ Connected busbars 24 V DC, M
- ④ Interrupted AUX bus
- ⑤ Interrupted busbars for the infeed system L1(L), L2(N), L3, PE
- ⑥ Infeed terminal for protective ground PE
- ⑦ Infeed terminal L3
- ⑧ Infeed terminal L2(N)
- ⑨ Infeed terminal L1(L)
- ⑩ Terminal for protective ground PE
- ⑪ Terminal T3
- ⑫ Terminal T2
- ⑬ Terminal T1

Figure 5-4 Block diagram of BaseUnit with 500 V AC infeed

### 5.4.3 Technical specifications

#### Technical specifications of the BaseUnit with 500 V AC infeed

<b>3RK1908-0AP00-0CP0</b>	
Product type designation	BU30-MS2
Galvanic isolation	
Galvanic isolation between backplane bus and supply voltage	Yes
Insulation tested with	2500 V AC
Rated operating voltage	24 V DC
Max. operating current	7 A (observe derating <sup>1)</sup> )
Rated insulation voltage in accordance with IEC 60947-1	500 V
Impulse withstand voltage/rated value $U_{imp}$ according to IEC 60947-1	6 kV
Operating voltage range	48 V AC to 500 V AC
Max. current-carrying capacity	32 A (observe derating <sup>1)</sup> )
Isolating function between the infeed terminals L1(L), L2 (N), L3 and motor feeder terminals T1, T2, T3 for motor starters in parking position, or removed motor starters: impulse withstand voltage/rated value $U_{imp}$ according to IEC 60947-1	6 kV
Wiring	
Push-in	Required tools for releasing: Standard screwdriver size 1 (SZF1 - 0.6x3.5)
Dimensions	
Width	30 mm
Height	215 mm
Weight, approx.	160 g

<sup>1)</sup> Derating table in SIMATIC ET 200SP Motor Starter manual  
<https://support.industry.siemens.com/cs/ww/en/view/109479973>

## 5.5 BU30-MS3 - BaseUnit with 24 V DC infeed

### 5.5.1 Product overview

#### Article number

3RK1908-0AP00-0BP0

## View



Figure 5-5 BaseUnit with 24 V DC infeed

## Properties

- BaseUnit suitable for all fail-safe and non-fail-safe SIMATIC ET 200SP High Feature motor starters
- The BaseUnit opens a new potential group (24 V DC). The potential group (24 V DC) is interrupted to the adjacent module on the left (BaseUnit, interface module/CPU).
- This BaseUnit takes over the infeed bus (500 V AC) of the left-hand BaseUnit and loops it through.
- Connection method using push-in terminals
- The touch protection cover for the infeed bus (3RK1908-1DA00-2BP0) is not included in the scope of delivery.
- The F-DI of the fail-safe motor starter is connected internally to the potential group (24 V DC). When the supply voltage (24 V DC) is applied, the motor starter is ready for operation.
- Version for HA system available: 3RK1908-0AP00-0BH0

## Maximum configuration per voltage group (24 V DC)

The number of I/O modules that can be used per potential group depends on the following factors:

1. Total power requirement of all I/O modules operated on this potential group
2. Total power requirement of all loads connected externally to this potential group

The total current calculated according to item 1. and item 2. must not exceed 7 A.

## 5.5.2 Connection

### Pin assignment

Pin assignment for BaseUnit with 24 V DC infeed	
Terminal	Descriptions
T1, T2, T3, PE	Motor feeder
24 V DC, M	24 V DC: Rated supply voltage 24 V DC with max. 7 A M: Ground

### Block diagram

The figure below shows the three-phase connection with 24 V infeed and mains infeed.

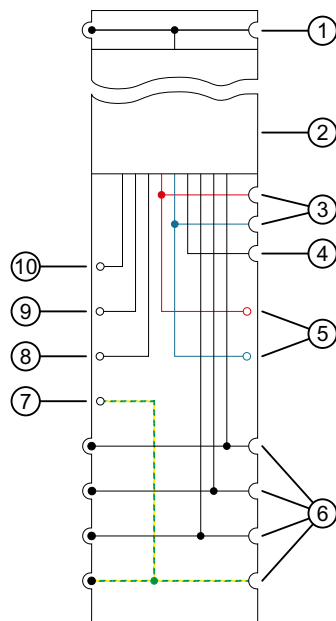

- ① Backplane bus
- ② Motor starter module
- ③ Interrupted busbars 24 V DC, M
- ④ Interrupted AUX bus
- ⑤ Terminal for 24 V DC and ground M
- ⑥ Connected busbars for the infeed system L1(L), L2(N), L3, PE
- ⑦ Terminal for protective ground PE
- ⑧ Terminal T3
- ⑨ Terminal T2
- ⑩ Terminal T1

Figure 5-6 Block diagram BaseUnit with 24 V DC infeed

### 5.5.3 Technical specifications

#### Technical specifications of the BaseUnit with 24 V DC infeed

<b>3RK1908-0AP00-0BP0</b>	
Product type designation	BU30-MS3
Galvanic isolation	
Galvanic isolation between backplane bus and supply voltage	Yes
Insulation tested with	2500 V AC
Rated operating voltage	24 V DC
Max. operating current	7 A (observe derating <sup>1)</sup> )
Rated insulation voltage in accordance with IEC 60947-1	500 V
Impulse withstand voltage/rated value $U_{imp}$ according to IEC 60947-1	6 kV
Operating voltage range	48 V AC to 500 V AC
Max. current-carrying capacity	32 A (observe derating <sup>1)</sup> )
Isolating function between the infeed terminals L1(L), L2 (N), L3 and motor feeder terminals T1, T2, T3 for motor starters in parking position, or removed motor starters: impulse withstand voltage/rated value $U_{imp}$ according to IEC 60947-1	6 kV
Wiring	
Push-in	Required tools for releasing: Standard screwdriver size 1 (SZF1 - 0.6x3.5)
Dimensions	
Width	30 mm
Height	215 mm
Weight, approx.	152 g

<sup>1)</sup> Derating table in SIMATIC ET 200SP Motor Starter manual (<https://support.industry.siemens.com/cs/ww/en/view/109479973>)

## 5.6 BU30-MS4 - BaseUnit without infeed

### 5.6.1 Product overview

#### Article number

3RK1908-0AP00-0DPO



## View



Figure 5-7 BaseUnit without infeed

## Properties

- BaseUnit suitable for all fail-safe and non-fail-safe SIMATIC ET 200SP High Feature motor starters
- No new potential groups are opened with this BaseUnit.
- The BaseUnit takes over the potential group (24 V DC) from the adjacent module on the left and loops it through.
- This BaseUnit takes over the infeed bus (500 V AC) of the left-hand BaseUnit and loops it through.
- Connection method using push-in terminals
- The touch protection cover for the infeed bus (3RK1908-1DA00-2BP0) is not included in the scope of delivery.
- The F-DI of the fail-safe motor starter is connected internally to the potential group (24 V DC). When the supply voltage (24 V DC) is applied, the motor starter is ready for operation.
- Version for HA system available: 3RK1908-0AP00-0DH0

### 5.6.2 Connection

#### Pin assignment

Pin assignment for BaseUnit without infeed	
Terminal	Descriptions
T1, T2, T3, PE	Motor feeder

#### Block diagram

The figure below shows the block diagram of the BaseUnit without infeed.

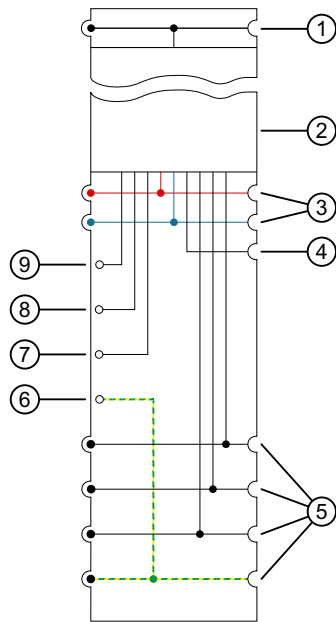

- ① Backplane bus
- ② Motor starter module
- ③ Connected busbars 24 V DC, M
- ④ Interrupted AUX bus
- ⑤ Connected busbars for the infeed system L1(L), L2(N), L3, PE
- ⑥ Terminal for protective ground PE
- ⑦ Terminal T3
- ⑧ Terminal T2
- ⑨ Terminal T1

Figure 5-8 Block diagram BaseUnit without infeed

### 5.6.3 Technical specifications

#### Technical specifications of BaseUnit without infeed

	<b>3RK1908-0AP00-0DP0</b>
Product type designation	BU30-MS4
Galvanic isolation	

<b>3RK1908-OAP00-ODP0</b>	
Galvanic isolation between backplane bus and supply voltage	Yes
Insulation tested with	2500 V AC
Rated operating voltage	24 V DC
Max. operating current	7 A (observe derating <sup>1)</sup> )
Rated insulation voltage in accordance with IEC 60947-1	500 V
Impulse withstand voltage/rated value $U_{imp}$ according to IEC 60947-1	6 kV
Operating voltage range	48 V AC to 500 V AC
Max. current-carrying capacity	32 A (observe derating <sup>1)</sup> )
Isolating function between the infeed terminals L1(L), L2 (N), L3 and motor feeder terminals T1, T2, T3 for motor starters in parking position, or removed motor starters: impulse withstand voltage/rated value $U_{imp}$ according to IEC 60947-1	6 kV
<b>Wiring</b>	
Push-in	Required tools for releasing: Standard screwdriver size 1 (SZF1 - 0.6x3.5)
<b>Dimensions</b>	
Width	30 mm
Height	215 mm
Weight, approx.	150 g

<sup>1)</sup> Derating table in SIMATIC ET 200SP Motor Starter manual  
<https://support.industry.siemens.com/cs/ww/en/view/109479973>

## 5.7 BU30-MS5 BaseUnit with 500 V AC infeed and single F-DI

### 5.7.1 Product overview

#### Article number

3RK1908-OAP00-OEPO

## View



Figure 5-9 BaseUnit with 500 V AC and F-DI

## Properties

- BaseUnit suitable for all fail-safe SIMATIC ET 200SP High Feature motor starters
- The BaseUnit takes over the potential group (24 V DC) from the adjacent module on the left and loops it through.
- The BaseUnit opens a new potential group (500 V AC). The infeed bus L1 (L), L2 (N), L3, PE is interrupted to the left-hand BaseUnit of the ET 200SP motor starter.
- Connection method using push-in terminals
- The touch protection cover for the infeed bus (3RK1908-1DA00-2BP0) is included in the scope of delivery.
- The BaseUnit has an F-DI input terminal for fail-safe control signals of the motor starter. This signal is not routed to neighboring motor starters.

## Maximum configuration of the supply bus

The number of I/O modules that can be used per potential group depends on the following factors:

1. Total power requirement of all I/O modules operated on this potential group
2. Total power requirement of all loads connected externally to this potential group

The total current calculated according to item 1. and item 2. must not exceed 7 A.

## Properties of the F-DI

The fail-safe digital input "F-DI" has the following properties:

- Use of interconnection type 1oo1
- Sink input (P-reading)
- Input delay 10 ms
- Status display of the F-DI on the motor starter module (green LED)

## 5.7.2 Connection

### Pin assignment

Pin assignment for BaseUnit with 500 V AC infeed and F-DI	
Terminal	Descriptions
T1, T2, T3, PE	Motor feeder
F-DI, M	F-DI: Connection of fail-safe signal M: Reference potential of fail-safe signal
L1(L), L2(N), L3, PE	Power supply Assignment is determined by the motor starter. You can find more information in the ET 200SP Motor Starter ( <a href="https://support.industry.siemens.com/cs/ww/en/view/109479973">https://support.industry.siemens.com/cs/ww/en/view/109479973</a> ) manual.

### Block diagram

The figure below shows the two-phase connection with 500 V AC infeed and F-DI:

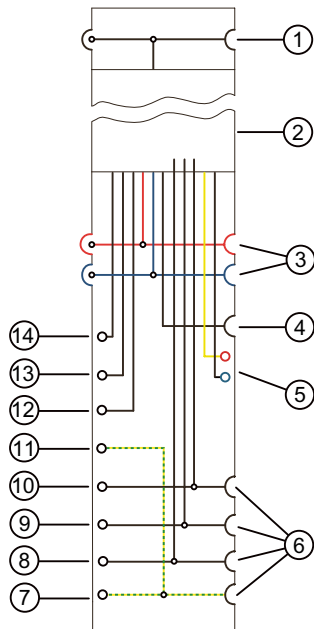

5.7 BU30-MS5 BaseUnit with 500 V AC infeed and single F-DI

- ① Backplane bus
- ② Motor starter module
- ③ Connected busbars 24 V DC, M
- ④ Interrupted AUX bus
- ⑤ F-DI (P24/M)
- ⑥ Interrupted busbars for the infeed system L1(L), L2(N), L3, PE
- ⑦ Infeed terminal for protective ground PE
- ⑧ Infeed terminal L3
- ⑨ Infeed terminal L2(N)
- ⑩ Infeed terminal L1(L)
- ⑪ Terminal for protective ground PE
- ⑫ Terminal T3
- ⑬ Terminal T2
- ⑭ Terminal T1

Figure 5-10 Block diagram of BaseUnit with 500 V AC infeed and fail-safe input

### 5.7.3 Technical specifications

#### Technical specifications of the BaseUnit with 500 V AC infeed and F-DI

<b>3RK1908-0AP00-0EPO</b>	
Product type designation	BU30-MS5
Galvanic isolation	
Galvanic isolation between backplane bus and supply voltage	Yes
Insulation tested with	2500 V AC
Rated operating voltage	24 V DC
Max. operating current	7 A (observe derating <sup>1)</sup> )
Galvanic isolation between fail-safe digital input and supply voltage	Yes
F-DI	Type 1 according to DIN EN 61131-2
Input current F-DI for signal "1", typ.	5 mA
Rated insulation voltage in accordance with IEC 60947-1	500 V
Impulse withstand voltage/rated value $U_{imp}$ according to IEC 60947-1	6 kV
Operating voltage range	48 V AC to 500 V AC
Max. current-carrying capacity	32 A (observe derating <sup>1)</sup> )
Isolating function between the infeed terminals L1(L), L2 (N), L3 and motor feeder terminals T1, T2, T3 for motor starters in parking position, or removed motor starters: impulse withstand voltage/rated value $U_{imp}$ according to IEC 60947-1	6 kV
Wiring	
Push-in	Required tools for releasing: Standard screwdriver size 1 (SZF1 - 0.6x3.5)
Dimensions	

3RK1908-0AP00-0EP0	
Width	30 mm
Height	215 mm
Weight, approx.	152 g

<sup>1)</sup> Derating table in SIMATIC ET 200SP Motor Starter manual  
<https://support.industry.siemens.com/cs/ww/en/view/109479973>

## 5.8 BU30-MS6 Base Unit without infeed and with single F-DI

### 5.8.1 Product overview

#### Article number

3RK1908-0AP00-0FP0

#### View



Figure 5-11 BaseUnit without 500 V AC infeed, with F-DI

#### Properties

- BaseUnit suitable for all fail-safe SIMATIC ET 200SP High Feature motor starters
- No new potential groups are opened with this BaseUnit.
- The BaseUnit takes over the potential group (24 V DC) from the adjacent module on the left and loops it through.

5.8 BU30-MS6 Base Unit without infeed and with single F-DI

- This BaseUnit takes over the infeed bus (500 V AC) of the left-hand BaseUnit and loops it through.
- Connection method using push-in terminals
- The touch protection cover for the infeed bus (3RK1908-1DA00-2BP0) is not included in the scope of delivery.
- The BaseUnit has an F-DI input terminal for fail-safe control signals of the motor starter. This signal is not routed to neighboring motor starters.

**Properties of the F-DI**

The fail-safe digital input "F-DI" has the following properties:

- Use of interconnection type 1oo1
- Sink input (P-reading)
- Input delay 10 ms
- Status display of the F-DI on the motor starter module (green LED)

**5.8.2 Connection**

**Pin assignment**

Pin assignment for BaseUnit with 24 V DC infeed	
Terminal	Descriptions
T1, T2, T3, PE	Motor feeder
F-DI, M	F-DI: Connection of fail-safe signal M: Reference potential of fail-safe signal



## Block diagram

The following figure shows the block diagram for the BaseUnit without infeed, but with fail-safe input:

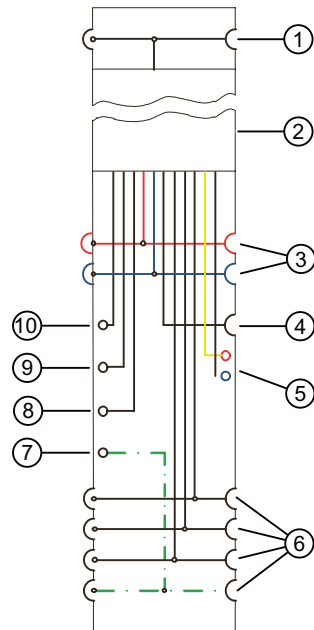

- ① Backplane bus
- ② Motor starter module
- ③ Connected busbars 24 V DC, M
- ④ Interrupted AUX bus
- ⑤ F-DI (P24/M)
- ⑥ Connected busbars infeed system L1, L2, L3, PE
- ⑦ Terminal for protective ground PE
- ⑧ Terminal T3
- ⑨ Terminal T2
- ⑩ Terminal T1

Figure 5-12 Block diagram of BaseUnit without infeed, with fail-safe input

### 5.8.3 Technical specifications

#### Technical specifications of BaseUnit without infeed, with F-DI

<b>3RK1908-0AP00-0FP0</b>	
Product type designation	BU30-MS6
Galvanic isolation	
Galvanic isolation between backplane bus and supply voltage	Yes
Insulation tested with	2500 V AC
Rated operating voltage	24 V DC
Max. operating current	7 A (observe derating <sup>1)</sup> )
Rated insulation voltage in accordance with IEC 60947-1	500 V

## 5.9 BU30-MS7 BaseUnit with F-DI and 500 V AC infeed

<b>3RK1908-0AP00-0FPO</b>	
Galvanic isolation between fail-safe digital input and supply voltage	Yes
F-DI	Type 1 according to DIN EN 61131-2
Input current F-DI for signal "1", typ.	5 mA
Impulse withstand voltage/rated value $U_{imp}$ according to IEC 60947-1	6 kV
Operating voltage range	48 V AC to 500 V AC
Max. current-carrying capacity	32 A (observe derating <sup>1)</sup> )
Isolating function between the infeed terminals L1(L), L2 (N), L3 and motor feeder terminals T1, T2, T3 for motor starters in parking position, or removed motor starters: impulse withstand voltage/rated value $U_{imp}$ according to IEC 60947-1	6 kV
Wiring	
Push-in	Required tools for releasing: Standard screwdriver size 1 (SZF1 - 0.6x3.5)
Dimensions	
Width	30 mm
Height	215 mm
Weight, approx.	152 g

<sup>1)</sup> Derating table in SIMATIC ET 200SP Motor Starter manual  
<https://support.industry.siemens.com/cs/ww/en/view/109479973>)

## 5.9 BU30-MS7 BaseUnit with F-DI and 500 V AC infeed

### 5.9.1 Product overview

#### Article number

3RK1908-0AP00-0GPO

## View



Figure 5-13 BaseUnit with F-DI and 500 V AC infeed

## Properties

- BaseUnit suitable for all fail-safe SIMATIC ET 200SP High Feature motor starters
- The BaseUnit takes over the potential group (24 V DC) from the adjacent module on the left and loops it through.
- The BaseUnit opens a new potential group (500 V AC). The infeed bus L1 (L), L2 (N), L3, PE is interrupted to the left-hand BaseUnit of the ET 200SP motor starter.
- Connection method using push-in terminals
- The touch protection cover (3RK1908-1DA00-2BP0) for the infeed bus is included in the scope of delivery.
- The BaseUnit has an F-DI input terminal for fail-safe control signals of the motor starter. These signals are routed to the adjacent motor starter on the right if a BU30-MS8 or BU30-MS9 is being used on the right side.

## Maximum configuration of the infeed bus (500 V AC)

The number of motor starters that can be used per infeed group depends on the following factors:

1. Total current requirement of all motor starters operated on this infeed group.
2. Ambient temperature and installation type in which the motor starters are operated. You can find further information in the derating table in the Manual SIMATIC ET 200SP Motor Starter (<https://support.industry.siemens.com/cs/ww/en/view/109479973>).

### Properties of the F-DI

The fail-safe digital input "F-DI" has the following properties:

- Use of interconnection type 1001
- Sink input (P-reading)
- Input delay 10 ms
- Status display of the F-DI on the motor starter module (green LED)

### Maximum configuration of F-DI routing

The number of BaseUnits for F-DI routing is possible for a system configuration up to 1 m.

## 5.9.2 Connecting up

### Pin assignment

Pin assignment for BaseUnit with F-DI and 500 V AC infeed	
Terminal	Descriptions
L1(L), L2(N), L3, PE	Power supply Assignment is determined by the motor starter. You can find more information in the ET 200SP Motor Starter ( <a href="https://support.industry.siemens.com/cs/ww/en/view/109479973">https://support.industry.siemens.com/cs/ww/en/view/109479973</a> ) manual.
T1, T2, T3, PE	Motor feeder
F-DI, M	F-DI: Connection of fail-safe signal M: Reference potential of fail-safe signal

### Block diagram

The figure below shows the block diagram of the BaseUnit with F-DI and 500 V AC infeed.

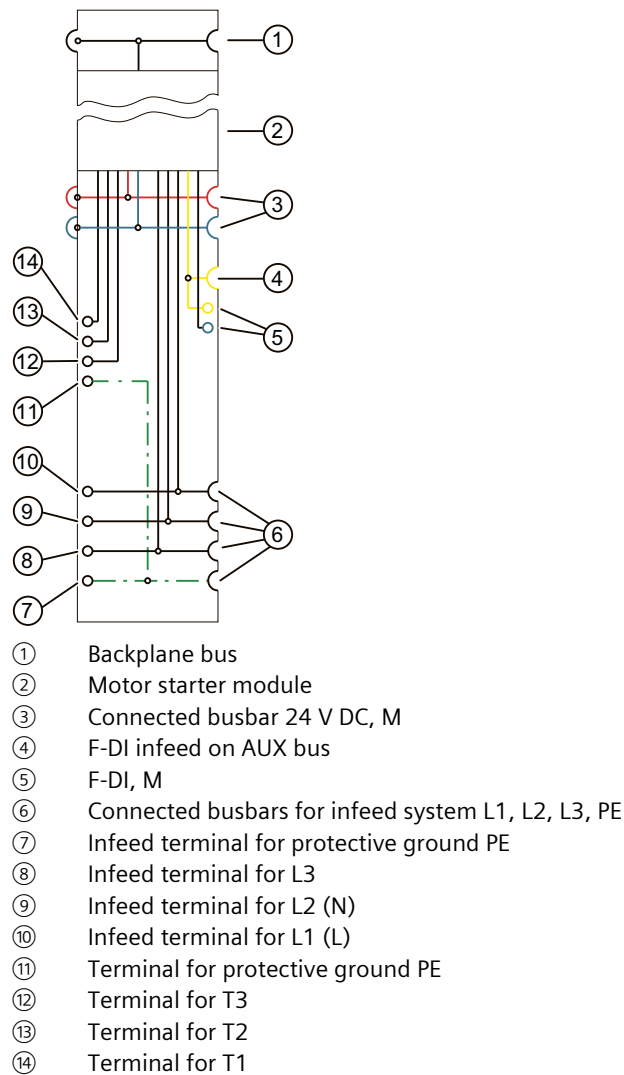

Figure 5-14 Block diagram of BaseUnit with F-DI and 500 V AC infeed

### 5.9.3 Technical specifications

#### Technical specifications of BaseUnit with F-DI and 500 V AC infeed

<b>3RK1908-0AP00-0GP0</b>	
Product type designation	BU30-MS7
Galvanic isolation	
Galvanic isolation between backplane bus and supply voltage	Yes
F-DI	Type 1 according to DIN EN 61131-2 5 mA
Input current F-DI for signal "1", typ.	5 mA
Insulation tested with	2500 V AC
Rated operating voltage	24 V DC
Max. operating current	7 A (observe derating <sup>1)</sup> )

5.10 BU30-MS8 BaseUnit with 500 V AC infeed and F-DI routing

<b>3RK1908-0AP00-0GPO</b>	
Rated insulation voltage in accordance with IEC 60947-1	500 V
Impulse withstand voltage/rated value $U_{imp}$ according to IEC 60947-1	6 kV
Operating voltage range	48 V AC to 500 V AC
Max. current-carrying capacity	32 A (observe derating <sup>1)</sup> )
Isolating function between the infeed terminals L1(L), L2 (N), L3 and motor feeder terminals T1, T2, T3 for motor starters in parking position, or removed motor starters: impulse withstand voltage/rated value $U_{imp}$ according to IEC 60947-1	6 kV
<b>Wiring</b>	
Push-in	Required tools for releasing: Standard screwdriver size 1 (SZF1 - 0.6x3.5)
<b>Dimensions</b>	
Width	30 mm
Height	215 mm
<b>Weights</b>	
Weight, approx.	164 g

<sup>1)</sup> Derating table in SIMATIC ET 200SP Motor Starter manual  
<https://support.industry.siemens.com/cs/ww/en/view/109479973>

## 5.10 BU30-MS8 BaseUnit with 500 V AC infeed and F-DI routing

### 5.10.1 Product overview

**Article number**

3RK1908-0AP00-0HPO

## View



Figure 5-15 BaseUnit with 500 V AC infeed and F-DI routing

## Properties

- BaseUnit suitable for all fail-safe SIMATIC ET 200SP High Feature motor starters
- The BaseUnit takes over the potential group (24 V DC) from the adjacent module on the left and loops it through.
- The BaseUnit opens a new potential group (500 V AC). The infeed bus L1 (L), L2 (N), L3, PE is interrupted to the left-hand BaseUnit of the ET 200SP motor starter.
- Connection method using push-in terminals
- The touch protection cover for the infeed bus (3RK1908-1DA00-2BP0) is included in the scope of delivery.
- The BaseUnit takes over the fail-safe control signals from the adjacent BU30-MS7 or BU30-MS10 BaseUnit on the left. This signal is routed to the adjacent motor starter on the right if a BU30-MS8 or BU30-MS9 is being used on the right side.

## Maximum configuration of the infeed bus (500 V AC)

The number of motor starters that can be used per infeed group depends on the following factors:

1. Total current requirement of all motor starters operated on this infeed group.
2. Ambient temperature and installation type in which the motor starters are operated. You can find further information in the derating table in the Manual SIMATIC ET 200SP Motor Starter (<https://support.industry.siemens.com/cs/ww/en/view/109479973>).

### Maximum configuration of F-DI routing

The number of BaseUnits for F-DI routing is possible for a system configuration up to 1 m.

### 5.10.2 Connection

#### Pin assignment

Pin assignment for BaseUnit with 500 V AC infeed and F-DI routing	
Terminal	Descriptions
L1(L), L2(N), L3, PE	Power supply Assignment is determined by the motor starter. See Manual ET 200SP motor starters ( <a href="https://support.industry.siemens.com/cs/ww/en/view/109479973">https://support.industry.siemens.com/cs/ww/en/view/109479973</a> ).
T1, T2, T3, PE	Motor feeder

#### Block diagram

The figure below shows the block diagram of the BaseUnit with 500 V AC infeed.

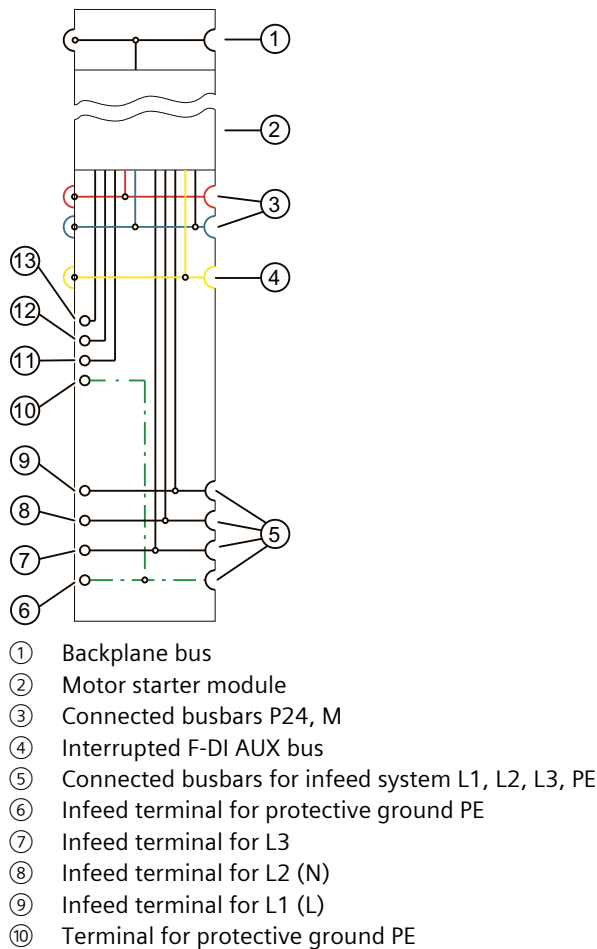



- ⑪ Terminal for T3
- ⑫ Terminal for T2
- ⑬ Terminal for T1

Figure 5-16 Block diagram of BaseUnit with 500 V AC infeed

### 5.10.3 Technical specifications

#### Technical specifications of BaseUnit with 500 V AC infeed and F-DI routing

<b>3RK1908-0AP00-0HP0</b>	
Product type designation	BU30-MS8
Galvanic isolation	
Galvanic isolation between backplane bus and supply voltage	Yes
F-DI	Type 1 according to DIN EN 61131-2 Input current F-DI for signal "1", typ. 5 mA
Insulation tested with	2500 V AC
Rated operating voltage	24 V DC
Max. operating current	7 A (observe derating <sup>1)</sup> )
Rated insulation voltage in accordance with IEC 60947-1	500 V
Impulse withstand voltage/rated value $U_{imp}$ according to IEC 60947-1	6 kV
Operating voltage range	48 V AC to 500 V AC
Max. current-carrying capacity	32 A (observe derating <sup>1)</sup> )
Isolating function between the infeed terminals L1(L), L2 (N), L3 and motor feeder terminals T1, T2, T3 for motor starters in parking position, or removed motor starters: impulse withstand voltage/rated value $U_{imp}$ according to IEC 60947-1	6 kV
<b>Wiring</b>	
Push-in	Required tools for releasing: Standard screwdriver size 1 (SZF1 - 0.6x3.5)
<b>Dimensions</b>	
Width	30 mm
Height	215 mm
Weight, approx.	160 g

<sup>1)</sup> Derating table in SIMATIC ET 200SP Motor Starter manual  
<https://support.industry.siemens.com/cs/ww/en/view/109479973>

## 5.11 BU30-MS9 BaseUnit with F-DI routing

### 5.11.1 Product overview

#### Article number

3RK1908-0AP00-0JPO

#### View



Figure 5-17 BaseUnit with F-DI routing

#### Properties

- BaseUnit suitable for all fail-safe SIMATIC ET 200SP High Feature motor starters
- No new potential groups are opened with this BaseUnit .
- The BaseUnit takes over the potential group (24 V DC) from the adjacent module on the left and loops this through.
- This BaseUnit takes over the infeed bus (500 V AC) of the left-hand BaseUnit and loops it through.
- Connection method using push-in terminals
- The touch protection cover for the infeed bus (3RK1908-1DA00-2BP0) is not included in the scope of delivery.
- The BaseUnit takes over the fail-safe control signals from the adjacent BU30-MS7 or BU30-MS10 BaseUnit on the left. This signal is routed to the adjacent motor starter on the right if a BU30-MS8 or BU30-MS9 is being used on the right side.

## Maximum configuration of F-DI routing

The number of BaseUnits for F-DI routing is possible for a system configuration up to 1 m.

### 5.11.2 Connection

#### Pin assignment

Pin assignment for BaseUnit with 24 V DC infeed	
Terminal	Descriptions
T1, T2, T3, PE	Motor feeder

#### Block diagram

The figure below shows the three-phase connection with 24 V infeed and mains infeed.

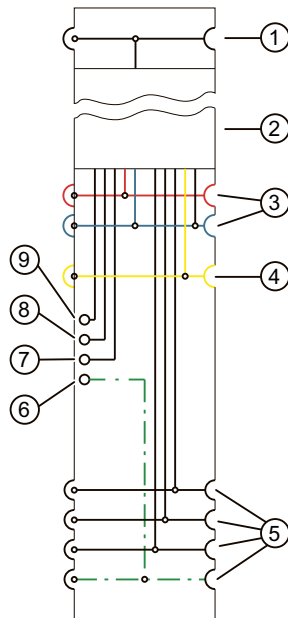

- ① Backplane bus
- ② Motor starter module
- ③ Connected busbars P24, M
- ④ Connected F-DI on AUX bus
- ⑤ Connected busbars for infeed system L1, L2, L3, PE
- ⑥ Terminal for protective ground
- ⑦ Terminal for T3
- ⑧ Terminal for T2
- ⑨ Terminal for T1

Figure 5-18 Block diagram of BaseUnit with F-DI routing

### 5.11.3 Technical specifications

#### Technical specifications of BaseUnit with F-DI routing

<b>3RK1908-0AP00-0JPO</b>	
Product type designation	BU30-MS9
Galvanic isolation	
Galvanic isolation between backplane bus and supply voltage	Yes
F-DI	Type 1 according to DIN EN 61131-2 5 mA
Input current F-DI for signal "1", typ.	5 mA
Insulation tested with	2500 V AC
Rated operating voltage	24 V DC
Max. operating current	7 A (observe derating <sup>1)</sup> )
Rated insulation voltage in accordance with IEC 60947-1	500 V
Galvanic isolation between fail-safe digital input and supply voltage	Yes
Impulse withstand voltage/rated value $U_{imp}$ according to IEC 60947-1	6 kV
Operating voltage range	48 V AC to 500 V AC
Max. current-carrying capacity	32 A (observe derating <sup>1)</sup> )
Isolating function between the infeed terminals L1(L), L2 (N), L3 and motor feeder terminals T1, T2, T3 for motor starters in parking position, or removed motor starters: impulse withstand voltage/rated value $U_{imp}$ according to IEC 60947-1	6 kV
Wiring	
Push-in	Required tools for releasing: Standard screwdriver size 1 (SZF1 - 0.6x3.5)
Dimensions	
Width	30 mm
Height	215 mm
Weight, approx.	152 g

<sup>1)</sup> Derating table in SIMATIC ET 200SP Motor Starter manual  
<https://support.industry.siemens.com/cs/ww/en/view/109479973>

## 5.12 BU30-MS10 BaseUnit with F-DI infeed

### 5.12.1 Product overview

#### Article number

3RK1908-0AP00-0KP0

## View



Figure 5-19 BU30-MS10 BaseUnit with F-DI infeed

## Properties

- BaseUnit suitable for all fail-safe SIMATIC ET 200SP High Feature motor starters
- No new potential groups are opened with this BaseUnit .
- The BaseUnit takes over the potential group (24 V DC) from the adjacent module on the left and loops it through.
- This BaseUnit takes over the infeed bus (500 V AC) of the left-hand BaseUnit and loops it through.
- Connection method using push-in terminals
- The touch protection cover for the infeed bus (3RK1908-1DA00-2BP0) is not included in the scope of delivery.
- The BaseUnit has an F-DI input terminal for fail-safe control signals of the motor starter. These signals are routed to the adjacent motor starter on the right if a BU30-MS8 or BU30-MS9 is being used on the right side.

## Properties of the F-DI

The fail-safe digital input "F-DI" has the following properties:

- Use of interconnection type 1oo1
- Sink input (P-reading)
- Input delay 10 ms
- Status display of the F-DI on the motor starter module (green LED)

### Maximum configuration of F-DI routing

The number of BaseUnits for F-DI routing is possible for a system configuration up to 1 m.

### 5.12.2 Connection

#### Pin assignment

Pin assignment for BaseUnit with infeed	
Terminal	Descriptions
T1, T2, T3, PE	Motor feeder
F-DI, M	F-DI: Connection of fail-safe signal M: Reference potential of fail-safe signal

#### Block diagram

The figure below shows the block diagram of the BaseUnit with F-DI infeed.

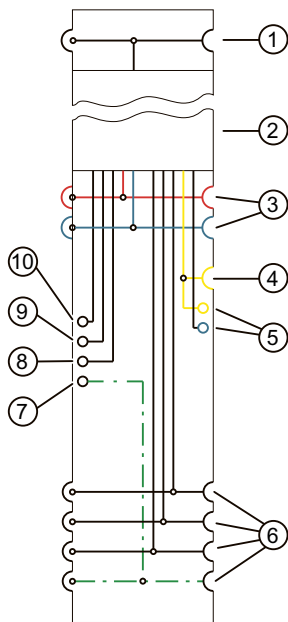

- ① Backplane bus
- ② Motor starter module
- ③ Connected busbars P24, M
- ④ F-DI infeed on AUX bus
- ⑤ F-DI, M
- ⑥ Connected busbars for infeed system L1, L2, L3, PE
- ⑦ Terminal for protective ground PE
- ⑧ Terminal for T3
- ⑨ Terminal for T2
- ⑩ Terminal for T1

Figure 5-20 Block diagram of BaseUnit with F-DI infeed

### 5.12.3 Technical specifications

#### Technical specifications of BaseUnit with F-DI infeed

<b>3RK1908-0AP00-0KP0</b>	
Product type designation	BU30-MS10
Galvanic isolation	
Galvanic isolation between backplane bus and supply voltage	Yes
F-DI	Type 1 according to DIN EN 61131-2 5 mA
Input current F-DI for signal "1", typ.	5 mA
Insulation tested with	2500 V AC
Rated operating voltage	24 V DC
Max. operating current	7 A (observe derating <sup>1)</sup> )
Rated insulation voltage in accordance with IEC 60947-1	500 V
Impulse withstand voltage/rated value $U_{imp}$ according to IEC 60947-1	6 kV
Operating voltage range	48 V AC to 500 V AC
Max. current-carrying capacity	32 A (observe derating <sup>1)</sup> )
Isolating function between the infeed terminals L1 (L), L2 (N), L3 and motor feeder terminals T1, T2, T3 for motor starters in parking position, or removed motor starters: Impulse withstand voltage/rated value $U_{imp}$ according to IEC 60947-1	6 kV
Wiring	
Push-in	Required tools for releasing: Standard screwdriver size 1 (SZF1 - 0.6x3.5)
Dimensions	
Width	30 mm
Height	215 mm
Weight, approx.	150 g

<sup>1)</sup> Derating table in SIMATIC ET 200SP Motor Starter manual  
<https://support.industry.siemens.com/cs/ww/en/view/109479973>

## Potential distributor modules

### 6.1 Introduction

#### Properties of potential distributor modules

A potential distributor module (PotDis module) consists of a potential distributor BaseUnit (PotDis-BU) and a potential distributor terminal block (PotDis-TB) installed on top of it.

A system-integrated potential distribution is possible with the various PotDis-BUs and PotDis-TBs.

You can place potential distributor modules at any location with the ET 200SP distributed I/O system. In doing so, you must observe the same design rules that apply to the design of a potential group from the BaseUnits for I/O modules. The following information is particularly important:

- The potential groups opened with a light-colored PotDis-BU must contain no I/O modules. You can integrate any dark-colored PotDis-BUs into I/O module potential groups provided these are based on SELV/PELV supply.
- If you do not need the additional terminals of the PotDis-TB in a potential distributor module, replace the PotDis-TB with a BU-Cover.
- You may only connect one potential group within a combination of PotDis-BU and PotDis-TB.
- Only SELV/PELV potentials are permitted on PotDis-BUs. Separate different SELV/PELV potential groups using light-colored PotDis-BUs.
- With potential distributor modules you may only connect to the PotDis-TB versions BR-W and n.c.-G potential, which exceed the voltage level of SELV/PELV.
- PotDis terminals are not directly configurable as PotDis via GSD/GSDML. When configuring with GSD, always use an empty module; with GSDML, integrate a free space.

Potential distributor modules are configurable with STEP 7/STEP 7 TIA Portal. Individual versions are listed in the following table:

Engineering with	version/HSP
STEP 7 TIA Portal	
<ul style="list-style-type: none"> <li>• Configurable as of version</li> <li>• Configurable as of version</li> <li>• Configurable as of version</li> <li>• Configurable as of version</li> </ul>	HSP0241 up to V13 SP1 Update 8 HSP0241 up to V14 HSP0241 up to V14 SP1 Update 5 HSP0241 up to V15 Update 1
STEP 7	
<ul style="list-style-type: none"> <li>• Configurable as of version</li> </ul>	HSP0293 up to V5.5 SP4

You can find additional information on the use of the potential distributor modules in the ET 200SP Distributed I/O System

(<http://support.automation.siemens.com/WW/view/en/58649293>) system manual.



## 6.2 PotDis-BU type P1, light-colored version

### 6.2.1 Short designation

#### Short designation

Light-colored version with 16 terminals to P1 + 2 supply terminals P1/P2.

Short designation: PotDis-BU-P1/D-R.

D stands for a new potential group, which means P1, P2, AUX separated to the left, R stands for red spring release.

### 6.2.2 Product overview

#### Delivery options (packing unit VPE)

6ES7193-6UP00-ODP1 (VPE: 1 unit)

#### View

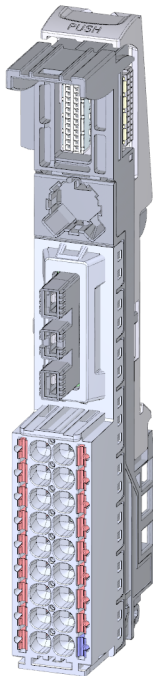

Figure 6-1 PotDis-BU type P1, light-colored version

### Properties

- BaseUnit suitable for all PotDis terminal blocks of the type "P1/P2/N0/P0". Can be recognized by the laser inscription on the front and/or the last two digits of the article number.
  - Supply voltage (terminal P1, P2) up to DC 48 V/10 A
  - Current carrying capacity per terminal: Max. 10 A
- BaseUnit opens up a new PotDis potential group. The self-assembling voltage buses P1, P2 and the AUX busbar are disconnected from the adjacent module on the left (BaseUnit, CPU, interface module).

<b>NOTICE</b>
<p><b>Opening a potential group for I/O modules is not permitted with the BaseUnit PotDis-BU-P1/D-R.</b></p> <p>The BaseUnit PotDis-BU-P1/D-R opens a new potential group only for the potential distributor modules. Opening a potential group for I/O modules is not permitted with the BaseUnit PotDis-BU-P1/D-R.</p>

- 18 terminals
  - 17 red terminals (P1)
  - 1 blue terminal (P2)
- 36 terminals (with PotDis-TB)
- Connection system in the form of push-in terminals

### 6.2.3 Connecting

#### Pin assignment

Pin assignment for BaseUnit PotDis-BU type P1, light-colored version	
Terminal	Explanation
P1	Rated supply voltage up to 48 V DC with max. 10 A (17 terminals)
P2	Ground (1 terminal)

## Block diagram

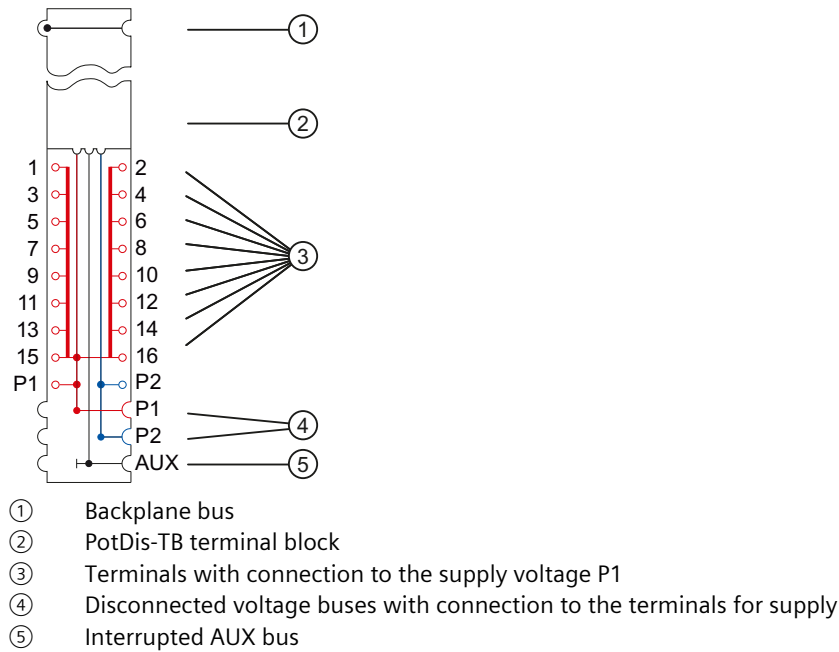

Figure 6-2 Block diagram of the PotDis-BU type P1, light-colored version

## 6.2.4 Technical specifications

### Technical specifications of the BaseUnit PotDis-BU type P1, light-colored version

Article number	6ES7193-6UP00-0DP1
<b>General information</b>	
Product type designation	PotDis BU type P1, light version, PU 1
HW functional status	FS10 and higher
<b>Supply voltage</b>	
Rated value (DC)	
• For P1 and P2 bus	48 V; max.
• for process terminals	48 V; max.
external protection for power supply lines	Yes; 10 A miniature circuit breaker with type B or C tripping characteristic for the respective rated supply voltage
<b>Current carrying capacity</b>	
For P1 and P2 bus, max.	10 A
For process terminals, max.	10 A
<b>Hardware configuration</b>	
<b>Formation of potential groups</b>	
• New potential group	Yes
• Potential group continued from the left	No
<b>Potential separation</b>	

6.3 PotDis-BU type P1, dark-colored version

<b>Article number</b>	<b>6ES7193-6UP00-ODP1</b>
between backplane bus and supply voltage	Yes
<b>Isolation</b>	
Isolation tested with	3 250 V DC
<b>Ambient conditions</b>	
<b>Ambient temperature during operation</b>	
<ul style="list-style-type: none"> <li>horizontal installation, min.</li> </ul>	-30 °C
<ul style="list-style-type: none"> <li>horizontal installation, max.</li> </ul>	60 °C
<ul style="list-style-type: none"> <li>vertical installation, min.</li> </ul>	-30 °C
<ul style="list-style-type: none"> <li>vertical installation, max.</li> </ul>	50 °C
<b>Altitude during operation relating to sea level</b>	
<ul style="list-style-type: none"> <li>Installation altitude above sea level, max.</li> </ul>	5 000 m; Restrictions for installation altitudes > 2 000 m, see manual
<b>Accessories</b>	
<b>Color coding labels</b>	
<ul style="list-style-type: none"> <li>for process terminals</li> </ul>	CC62
<b>Connection method</b>	
<b>Terminals</b>	
<ul style="list-style-type: none"> <li>Terminal type</li> </ul>	Push-in terminal
<ul style="list-style-type: none"> <li>Conductor cross-section, min.</li> </ul>	0.14 mm <sup>2</sup>
<ul style="list-style-type: none"> <li>Conductor cross-section, max.</li> </ul>	2.5 mm <sup>2</sup>
<ul style="list-style-type: none"> <li>Number of terminals with connection to P1 and P2 bus</li> </ul>	17 terminals to P1, 1 terminal to P2
<b>Dimensions</b>	
Width	15 mm
Height	117 mm
Depth	35 mm
<b>Weights</b>	
Weight, approx.	40 g

## 6.3 PotDis-BU type P1, dark-colored version

### Short designation

Dark-colored version with 16 terminals to P1 + 2 supply terminals P1/P2.

Short designation: PotDis-BU-P1/B-R.

B stands for bridged potential group, which means P1, P2, AUX bridged to the left, R stands for red spring release.

### 6.3.1 Product overview

#### Delivery options (packing unit VPE)

6ES7193-6UP00-OBP1 (VPE: 1 unit)

**View**

Figure 6-3 PotDis-BU type P1, dark-colored version

**Properties**

- BaseUnit suitable for all PotDis terminal blocks of the type "P1/P2/N0/P0". Can be recognized by the laser inscription on the front and/or the last two digits of the article number.
  - Current carrying capacity per terminal: Max. 10 A
- BaseUnit further conducts the potential group. The self-assembling voltage buses P1, P2 and the AUX busbar are connected to the adjacent module on the left (BaseUnit).
- 18 terminals
  - 17 red terminals (P1)
  - 1 blue terminal (P2)
- 36 terminals (with PotDis-TB)
- Connection system in the form of push-in terminals

**6.3.2 Connecting****Pin assignment**

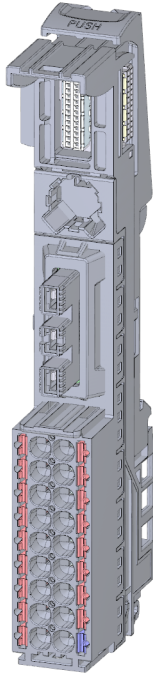
Pin assignment for BaseUnit PotDis-BU type P1, dark-colored version	
Terminal	Explanation
P1	Rated supply voltage up to 48 V DC with max. 10 A (17 terminals)
P2	Ground (1 terminal)

### Block diagram

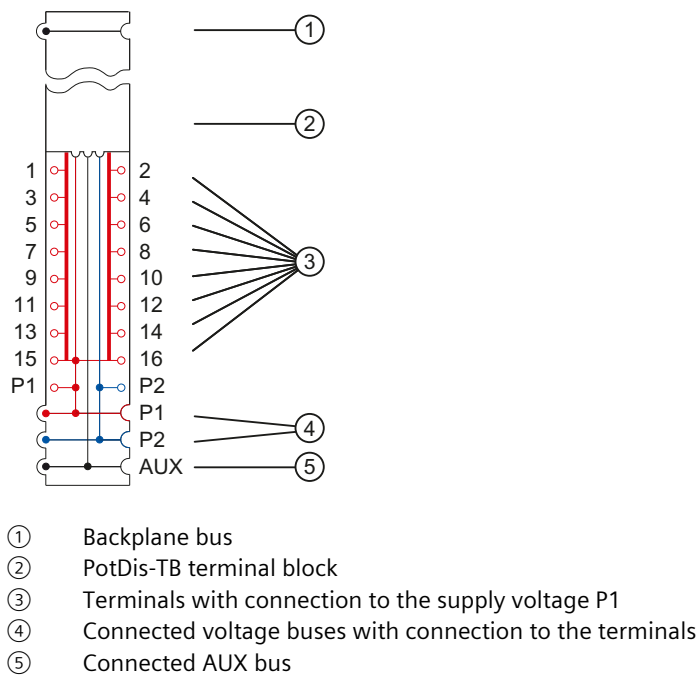

Figure 6-4 Block diagram of the PotDis-BU type P1, dark-colored version

### 6.3.3 Technical specifications

#### Technical specifications of the BaseUnit PotDis-BU type P1, dark-colored version

<b>Article number</b>	<b>6ES7193-6UP00-0BP1</b>
<b>General information</b>	
Product type designation	PotDis BU type P1, dark version, PU 1
HW functional status	FS10 and higher
<b>Supply voltage</b>	
Rated value (DC)	
• For P1 and P2 bus	48 V; max.
• for process terminals	48 V; max.
external protection for power supply lines	Yes; 10 A miniature circuit breaker with type B or C tripping characteristic for the respective rated supply voltage
<b>Current carrying capacity</b>	
For P1 and P2 bus, max.	10 A
For process terminals, max.	10 A
<b>Hardware configuration</b>	
<b>Formation of potential groups</b>	
• New potential group	No
• Potential group continued from the left	Yes

<b>Article number</b>	<b>6ES7193-6UP00-0BP1</b>
<b>Potential separation</b>	
between backplane bus and supply voltage	Yes
<b>Isolation</b>	
Isolation tested with	3 250 V DC
<b>Ambient conditions</b>	
<b>Ambient temperature during operation</b>	
• horizontal installation, min.	-30 °C
• horizontal installation, max.	60 °C
• vertical installation, min.	-30 °C
• vertical installation, max.	50 °C
<b>Altitude during operation relating to sea level</b>	
• Installation altitude above sea level, max.	5 000 m; Restrictions for installation altitudes > 2 000 m, see manual
<b>Accessories</b>	
<b>Color coding labels</b>	
• for process terminals	CC62
<b>Connection method</b>	
<b>Terminals</b>	
• Terminal type	Push-in terminal
• Conductor cross-section, min.	0.14 mm <sup>2</sup>
• Conductor cross-section, max.	2.5 mm <sup>2</sup>
• Number of terminals with connection to P1 and P2 bus	17 terminals to P1, 1 terminal to P2
<b>Dimensions</b>	
Width	15 mm
Height	117 mm
Depth	35 mm
<b>Weights</b>	
Weight, approx.	40 g

## 6.4 PotDis-BU type P2, light-colored version

### 6.4.1 Short designation

#### Short designation

Light-colored version with 16 terminals to P2 + 2 supply terminals P1/P2.

Short designation: PotDis-BU-P2/D-B.

D stands for a new potential group, which means P1, P2, AUX separated to the left, B stands for blue spring release.

## 6.4.2 Product overview

### Delivery options (packing unit VPE)

6ES7193-6UP00-ODP2 (VPE: 1 unit)

### View

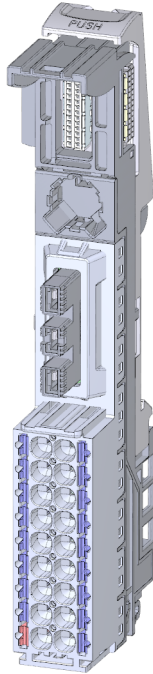

Figure 6-5 PotDis-BU type P2, light-colored version

### Properties

- BaseUnit suitable for all PotDis terminal blocks of the type "P1/P2/N0/P0". Can be recognized by the laser inscription on the front and/or the last two digits of the article number.
  - Supply voltage (terminal P1, P2) up to DC 48 V/10 A
  - Current carrying capacity per terminal: Max. 10 A
- BaseUnit opens up a new PotDis potential group. The self-assembling voltage buses P1, P2 and the AUX busbar are disconnected from the adjacent module on the left (BaseUnit, CPU, interface module).

#### NOTICE

##### Opening a potential group for I/O modules is not permitted with the BaseUnit PotDis-BU-P2/D-B.

The BaseUnit PotDis-BU-P2/D-B opens a new potential group only for the potential distributor modules. Opening a potential group for I/O modules is not permitted with the BaseUnit PotDis-BU-P2/D-B.



- 18 terminals
  - 1 red terminal (P1)
  - 17 blue terminals (P2)
- 36 terminals (with PotDis-TB)
- Connection system in the form of push-in terminals

### 6.4.3 Connecting

#### Pin assignment

Pin assignment for PotDis-BU type P2, light-colored version	
Terminal	Explanation
P1	Rated supply voltage up to 48 V DC with max. 10 A (1 terminal)
P2	Ground (17 terminals)

#### Block diagram

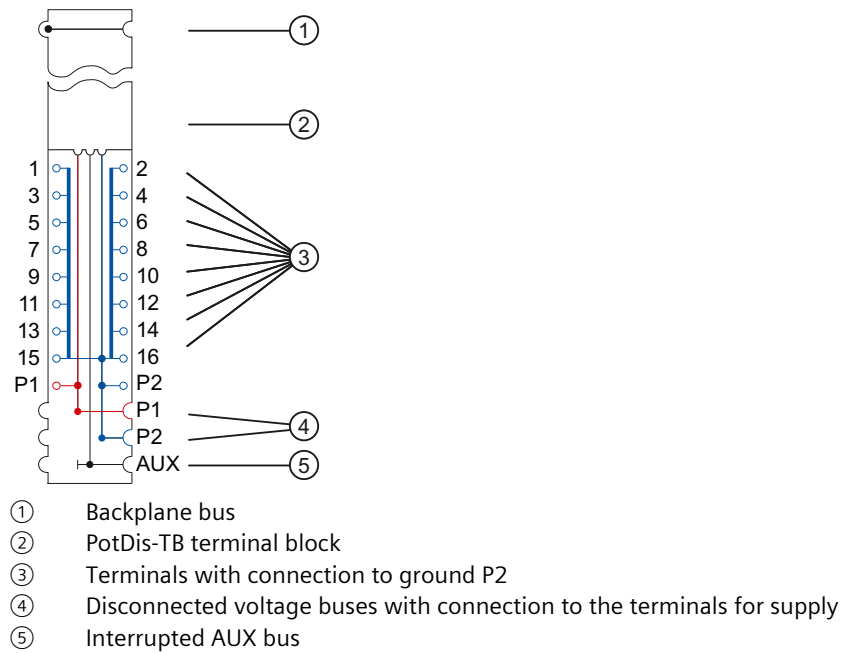

Figure 6-6 Block diagram of the PotDis-BU type P2, light-colored version

### 6.4.4 Technical specifications

#### Technical specifications of the BaseUnit PotDis-BU type P2, light-colored version

<b>Article number</b>	<b>6ES7193-6UP00-0DP2</b>
<b>General information</b>	
Product type designation	PotDis BU type P2, light version, PU 1
HW functional status	FS10 and higher
<b>Supply voltage</b>	
Rated value (DC)	
<ul style="list-style-type: none"> <li>For P1 and P2 bus</li> <li>for process terminals</li> </ul>	<p>48 V; max.</p> <p>48 V; max.</p>
external protection for power supply lines	Yes; 10 A miniature circuit breaker with type B or C tripping characteristic for the respective rated supply voltage
<b>Current carrying capacity</b>	
For P1 and P2 bus, max.	10 A
For process terminals, max.	10 A
<b>Hardware configuration</b>	
<b>Formation of potential groups</b>	
<ul style="list-style-type: none"> <li>New potential group</li> <li>Potential group continued from the left</li> </ul>	<p>No</p> <p>Yes</p>
<b>Potential separation</b>	
between backplane bus and supply voltage	Yes
<b>Isolation</b>	
Isolation tested with	3 250 V DC
<b>Ambient conditions</b>	
<b>Ambient temperature during operation</b>	
<ul style="list-style-type: none"> <li>horizontal installation, min.</li> <li>horizontal installation, max.</li> <li>vertical installation, min.</li> <li>vertical installation, max.</li> </ul>	<p>-30 °C</p> <p>60 °C</p> <p>-30 °C</p> <p>50 °C</p>
<b>Altitude during operation relating to sea level</b>	
<ul style="list-style-type: none"> <li>Installation altitude above sea level, max.</li> </ul>	5 000 m; Restrictions for installation altitudes > 2 000 m, see manual
<b>Accessories</b>	
<b>Color coding labels</b>	
<ul style="list-style-type: none"> <li>for process terminals</li> </ul>	CC63
<b>Connection method</b>	
<b>Terminals</b>	
<ul style="list-style-type: none"> <li>Terminal type</li> <li>Conductor cross-section, min.</li> <li>Conductor cross-section, max.</li> </ul>	<p>Push-in terminal</p> <p>0.14 mm<sup>2</sup></p> <p>2.5 mm<sup>2</sup></p>

<b>Article number</b>	<b>6ES7193-6UP00-ODP2</b>
<ul style="list-style-type: none"> <li>Number of terminals with connection to P1 and P2 bus</li> </ul>	18; 17 terminals to P2, 1 terminal to P1
<b>Dimensions</b>	
Width	15 mm
Height	117 mm
Depth	35 mm
<b>Weights</b>	
Weight, approx.	40 g

## 6.5 PotDis-BU type P2, dark-colored version

### 6.5.1 Short designation

#### Short designation

Dark-colored version with 16 terminals to P2 + 2 supply terminals P1/P2.

Short designation: PotDis-BU-P2/B-B.

B stands for a jumpered potential group, this means P1, P2, AUX jumpered to the left, B stands for blue spring release.

### 6.5.2 Product overview

#### Delivery options (packing unit VPE)

6ES7193-6UP00-OBP2 (VPE: 1 unit)

**View**

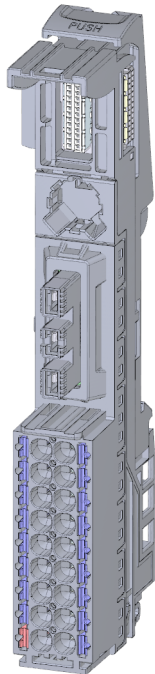

Figure 6-7 PotDis-BU type P2, dark-colored version

**Properties**

- BaseUnit suitable for all PotDis terminal blocks of the type "P1/P2/N0/P0". Can be recognized by the laser inscription on the front and/or the last two digits of the article number.
  - Current carrying capacity per terminal: Max. 10 A
- BaseUnit further conducts the potential group. The self-assembling voltage buses P1, P2 and the AUX busbar are connected to the adjacent module on the left (BaseUnit).
- 18 terminals
  - 1 red terminal (P1)
  - 17 blue terminals (P2)
- 36 terminals (with PotDis-TB)
- Connection system in the form of push-in terminals

**6.5.3 Connecting**

**Pin assignment**

Pin assignment for PotDis-BU type P2, dark-colored version	
Terminal	Explanation
P1	Rated supply voltage up to 48 V DC with max. 10 A (1 terminal)
P2	Ground (17 terminals)

## Block diagram

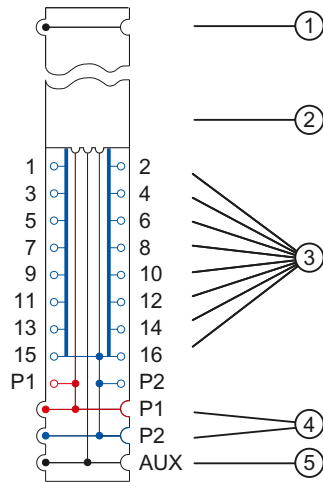

- ① Backplane bus
- ② PotDis-TB terminal block
- ③ Terminals with connection to ground P2
- ④ Connected voltage buses with connection to the terminals
- ⑤ Connected AUX bus

Figure 6-8 Block diagram of the PotDis-BU type P2, dark-colored version

## 6.5.4 Technical specifications

### Technical specifications of the BaseUnit PotDis-BU type P2, dark-colored version

Article number	6ES7193-6UP00-0BP2
<b>General information</b>	
Product type designation	PotDis BU type P2, dark version, PU 1
HW functional status	FS10 and higher
<b>Supply voltage</b>	
Rated value (DC)	
<ul style="list-style-type: none"> <li>• For P1 and P2 bus</li> <li>• for process terminals</li> </ul>	48 V; max. 48 V; max.
external protection for power supply lines	Yes; 10 A miniature circuit breaker with type B or C tripping characteristic for the respective rated supply voltage
<b>Current carrying capacity</b>	
For P1 and P2 bus, max.	10 A
For process terminals, max.	10 A
<b>Hardware configuration</b>	
<b>Formation of potential groups</b>	
<ul style="list-style-type: none"> <li>• New potential group</li> <li>• Potential group continued from the left</li> </ul>	No Yes

6.6 PotDis-TB

<b>Article number</b>	<b>6ES7193-6UP00-0BP2</b>
<b>Potential separation</b>	
between backplane bus and supply voltage	Yes
<b>Isolation</b>	
Isolation tested with	3 250 V DC
<b>Ambient conditions</b>	
<b>Ambient temperature during operation</b>	
• horizontal installation, min.	-30 °C
• horizontal installation, max.	60 °C
• vertical installation, min.	-30 °C
• vertical installation, max.	50 °C
<b>Altitude during operation relating to sea level</b>	
• Installation altitude above sea level, max.	5 000 m; Restrictions for installation altitudes > 2 000 m, see manual
<b>Accessories</b>	
<b>Color coding labels</b>	
• for process terminals	CC63
<b>Connection method</b>	
<b>Terminals</b>	
• Terminal type	Push-in terminal
• Conductor cross-section, min.	0.14 mm <sup>2</sup>
• Conductor cross-section, max.	2.5 mm <sup>2</sup>
• Number of terminals with connection to P1 and P2 bus	18; 17 terminals to P2, 1 terminal to P1
<b>Dimensions</b>	
Width	15 mm
Height	117 mm
Depth	35 mm
<b>Weights</b>	
Weight, approx.	40 g

## 6.6 PotDis-TB

### 6.6.1 Product overview

#### Article number

- PotDis-TB-P1-R terminal block: 6ES7193-6TP00-0TP1
- PotDis-TB-P2-B terminal block: 6ES7193-6TP00-0TP2
- PotDis-TB-n.c.-G terminal block: 6ES7193-6TP00-0TNO
- PotDis-TB-BR-W terminal block: 6ES7193-6TP00-0TPO

## View

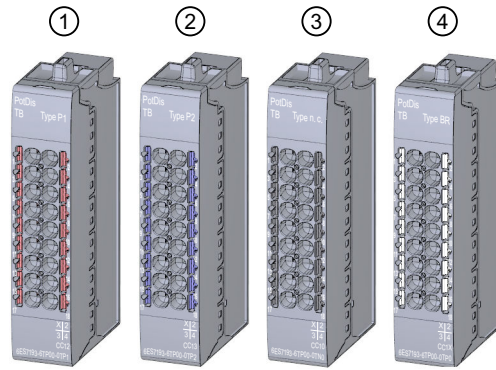

- ① PotDis-TB-P1-R
- ② PotDis-TB-P2-B
- ③ PotDis-TB-n.c.-G
- ④ PotDis-TB-BR-W

Figure 6-9 PotDis terminal blocks

## Properties

- Terminal blocks matching all BaseUnits PotDis-BU
  - Current carrying capacity per terminal: Max. 10 A
- 18 terminals
  - PotDis-TB-P1-R terminal block: Red terminals with connection to the supply voltage P1 of the BaseUnit PotDis-BU
  - PotDis-TB-P2-B terminal block: Blue terminals with connection to ground P2 of the BaseUnit PotDis-BU
  - PotDis-TB-n.c.-G terminal block: Gray (internal not connected) terminals without connection to the BaseUnit PotDis-BU

**NOTICE****Mixed connection of direct current or alternating current (DC/AC) is not permitted on the PotDis-TB-n.c-G**

Connect direct currents up to 48 V or alternating currents up to 230 V to the terminals of the PotDis-TB-n.c.-G. A mixed connection of both types of voltages (DC/AC) is not permitted at the terminals of the PotDis-TB-n.c.-G.

- PotDis-TB-BR-W terminal block: White (internal not connected) terminals without connection to the BaseUnit-BU

**NOTICE****Only PotDis-TB-BR may be used for protective conductors.**

Check all protective conductors.

Check the required conductor cross-section for the respective plant unit before commissioning of the plant (especially for motor starters).

6.6 PotDis-TB

- Connection system in the form of push-in terminals
- You can find the assignment of color-coded labels in the ET 200SP System Manual under Accessories.

<b>NOTICE</b>
<b>Use of color-coded labels</b> Before commissioning the system, check that the color-coded labels attached correspond to the wired potential.

<b>NOTICE</b>
<b>Voltages greater than SELV/PELV</b> Voltages greater than SELV/PELV are only permitted for the PO PotDis-TBs BR (bridged) and NC (not connected). This applies equally to protective conductors. No voltages greater than SELV/PELV are present on the terminals of the PotDis module with connection to the P1/P2 rails.

## 6.6.2 Connecting

### Pin assignment

Pin assignment for PotDis-TB terminal block		
Terminal block	Terminal	Explanation
PotDis-TB-P1-R	P1	Rated supply voltage up to 48 V DC with max. 10 A (18 red terminals)
PotDis-TB-P2-B	P2	Ground (18 blue terminals)
PotDis-TB-n.c.-G	n c. (not connected)	Terminals can be used freely up to 230 V AC with max. 10 A (18 gray terminals). If you connect voltage, it must belong to the same potential group.
PotDis-TB-BR-W	BR (bridged)	Terminals for protective conductor connection or voltage bus freely usable up to 230 V AC with max. 10 A (18 white terminals)



### Block diagram

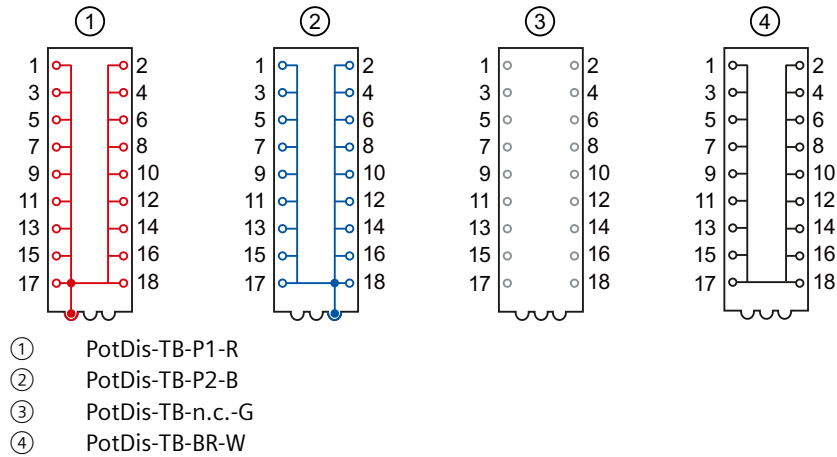

Figure 6-10 PotDis-TB block diagram

### 6.6.3 Technical specifications

#### Technical specifications of the PotDis-TB-P1\_R terminal block

Article number	6ES7193-6TP00-0TP1
<b>General information</b>	
Product type designation	PotDis TB P1-R, PU 1
HW functional status	FS10 and higher
<b>Supply voltage</b>	
Rated value (DC)	
<ul style="list-style-type: none"> <li>For P1 and P2 bus</li> <li>for process terminals</li> </ul>	48 V; max.
external protection for power supply lines	48 V; max.
	Yes; 10 A miniature circuit breaker with type B or C tripping characteristic for the respective rated supply voltage
<b>Current carrying capacity</b>	
up to 60 °C, max.	10 A
For P1 and P2 bus, max.	10 A
For process terminals, max.	10 A
<b>Ambient conditions</b>	
<b>Ambient temperature during operation</b>	
<ul style="list-style-type: none"> <li>horizontal installation, min.</li> <li>horizontal installation, max.</li> <li>vertical installation, min.</li> <li>vertical installation, max.</li> </ul>	-30 °C 60 °C -30 °C 50 °C
<b>Altitude during operation relating to sea level</b>	
<ul style="list-style-type: none"> <li>Installation altitude above sea level, max.</li> </ul>	5 000 m; Restrictions for installation altitudes > 2 000 m, see manual

6.6 PotDis-TB

<b>Article number</b>	<b>6ES7193-6TP00-0TP1</b>
<b>Accessories</b>	
<b>Color coding labels</b>	
<ul style="list-style-type: none"> <li>for process terminals</li> </ul>	CC10, CC12
<b>Connection method</b>	
<b>Terminals</b>	
<ul style="list-style-type: none"> <li>Terminal type</li> <li>Conductor cross-section, min.</li> <li>Conductor cross-section, max.</li> <li>Number of process terminals to I/O module</li> <li>Number of terminals to AUX bus</li> <li>Number of add-on terminals</li> <li>Number of terminals with connection to P1 and P2 bus</li> </ul>	Push-in terminal 0.14 mm <sup>2</sup> ; 0.2 mm <sup>2</sup> without wire end ferrule 2.5 mm <sup>2</sup> ; 1.5 mm <sup>2</sup> with wire end ferrule 16 0 0 2
<b>Dimensions</b>	
Width	15 mm
Height	74 mm
Depth	34 mm
<b>Weights</b>	
Weight, approx.	24 g

Technical specifications of the PotDis-TB-P2-B terminal block

<b>Article number</b>	<b>6ES7193-6TP00-0TP2</b>
<b>General information</b>	
Product type designation	PotDis TB P2-B, PU 1
HW functional status	FS10 and higher
<b>Supply voltage</b>	
Rated value (DC)	
<ul style="list-style-type: none"> <li>For P1 and P2 bus</li> <li>for process terminals</li> </ul>	48 V; max. 48 V; max.
external protection for power supply lines	Yes; 10 A miniature circuit breaker with type B or C tripping characteristic for the respective rated supply voltage
<b>Current carrying capacity</b>	
up to 60 °C, max.	10 A
For P1 and P2 bus, max.	10 A
For process terminals, max.	10 A
<b>Potential separation</b>	
between process terminals and supply voltage	No
<b>Ambient conditions</b>	
<b>Ambient temperature during operation</b>	

<b>Article number</b>	<b>6ES7193-6TP00-0TP2</b>
<ul style="list-style-type: none"> <li>horizontal installation, min.</li> <li>horizontal installation, max.</li> <li>vertical installation, min.</li> <li>vertical installation, max.</li> </ul>	<p>-30 °C</p> <p>60 °C</p> <p>-30 °C</p> <p>50 °C</p>
<b>Altitude during operation relating to sea level</b>	
<ul style="list-style-type: none"> <li>Installation altitude above sea level, max.</li> </ul>	5 000 m; Restrictions for installation altitudes > 2 000 m, see manual
<b>Accessories</b>	
<b>Color coding labels</b>	
<ul style="list-style-type: none"> <li>for process terminals</li> </ul>	CC10, CC13
<b>Connection method</b>	
<b>Terminals</b>	
<ul style="list-style-type: none"> <li>Terminal type</li> <li>Conductor cross-section, min.</li> <li>Conductor cross-section, max.</li> <li>Number of process terminals to I/O module</li> <li>Number of terminals to AUX bus</li> <li>Number of add-on terminals</li> <li>Number of terminals with connection to P1 and P2 bus</li> </ul>	<p>Push-in terminal</p> <p>0.14 mm<sup>2</sup>; 0.2 mm<sup>2</sup> without wire end ferrule</p> <p>2.5 mm<sup>2</sup>; 1.5 mm<sup>2</sup> with wire end ferrule</p> <p>16</p> <p>0</p> <p>0</p> <p>2</p>
<b>Dimensions</b>	
Width	15 mm
Height	74 mm
Depth	34 mm
<b>Weights</b>	
Weight, approx.	24 g

### Technical specifications of the PotDis-TB-n.c.-G

<b>Article number</b>	<b>6ES7193-6TP00-0TN0</b>
<b>General information</b>	
Product type designation	PotDis TB n.c. G, PU 1
HW functional status	FS10 and higher
<b>Supply voltage</b>	
Rated value (DC)	
<ul style="list-style-type: none"> <li>for process terminals</li> </ul>	48 V; max.
Rated value (AC)	
<ul style="list-style-type: none"> <li>for process terminals</li> </ul>	240 V; max.
external protection for power supply lines	Yes; 10 A miniature circuit breaker with type B or C tripping characteristic for the respective rated supply voltage

<b>Article number</b>	<b>6ES7193-6TP00-0TNO</b>
<b>Current carrying capacity</b>	
up to 60 °C, max.	10 A
For P1 and P2 bus, max.	10 A
<b>Potential separation</b>	
between process terminals and supply voltage	Yes
<b>Ambient conditions</b>	
<b>Ambient temperature during operation</b>	
• horizontal installation, min.	-30 °C
• horizontal installation, max.	60 °C
• vertical installation, min.	-30 °C
• vertical installation, max.	50 °C
<b>Altitude during operation relating to sea level</b>	
• Installation altitude above sea level, max.	5 000 m; Restrictions for installation altitudes > 2 000 m, see manual
<b>Accessories</b>	
<b>Color coding labels</b>	
• for process terminals	CC10
<b>Connection method</b>	
<b>Terminals</b>	
• Terminal type	Push-in terminal
• Conductor cross-section, min.	0.14 mm <sup>2</sup> ; 0.2 mm <sup>2</sup> without wire end ferrule
• Conductor cross-section, max.	2.5 mm <sup>2</sup> ; 1.5 mm <sup>2</sup> with wire end ferrule
• Number of process terminals to I/O module	16
• Number of terminals to AUX bus	0
• Number of add-on terminals	0
• Number of terminals with connection to P1 and P2 bus	2
<b>Dimensions</b>	
Width	15 mm
Height	74 mm
Depth	34 mm
<b>Weights</b>	
Weight, approx.	24 g

### Technical specifications of the PotDis-TB-BR-W terminal block

<b>Article number</b>	<b>6ES7193-6TP00-0TPO</b>
<b>General information</b>	
Product type designation	PotDis TB BR-W, PU 1
HW functional status	FS10 and higher
<b>Supply voltage</b>	

Article number	6ES7193-6TP00-0TPO
Rated value (DC) <ul style="list-style-type: none"> <li>for process terminals</li> </ul>	48 V; max.
Rated value (AC) <ul style="list-style-type: none"> <li>for process terminals</li> </ul> external protection for power supply lines	240 V; max. Yes; 10 A miniature circuit breaker with type B or C tripping characteristic for the respective rated supply voltage
Current carrying capacity	
up to 60 °C, max.	10 A
For P1 and P2 bus, max.	10 A
For process terminals, max.	10 A
Potential separation	
between process terminals and supply voltage	Yes
Ambient conditions	
Ambient temperature during operation	
<ul style="list-style-type: none"> <li>horizontal installation, min.</li> </ul>	-30 °C
<ul style="list-style-type: none"> <li>horizontal installation, max.</li> </ul>	60 °C
<ul style="list-style-type: none"> <li>vertical installation, min.</li> </ul>	-30 °C
<ul style="list-style-type: none"> <li>vertical installation, max.</li> </ul>	50 °C
Altitude during operation relating to sea level	
<ul style="list-style-type: none"> <li>Installation altitude above sea level, max.</li> </ul>	5 000 m; Restrictions for installation altitudes > 2 000 m, see manual
Accessories	
Color coding labels	
<ul style="list-style-type: none"> <li>for process terminals</li> </ul>	CC10, CC11, CC12, CC13
Connection method	
Terminals	
<ul style="list-style-type: none"> <li>Terminal type</li> </ul>	Push-in terminal
<ul style="list-style-type: none"> <li>Conductor cross-section, min.</li> </ul>	0.14 mm <sup>2</sup> ; 0.2 mm <sup>2</sup> without wire end ferrule
<ul style="list-style-type: none"> <li>Conductor cross-section, max.</li> </ul>	2.5 mm <sup>2</sup> ; 1.5 mm <sup>2</sup> with wire end ferrule
<ul style="list-style-type: none"> <li>Number of process terminals to I/O module</li> </ul>	16
<ul style="list-style-type: none"> <li>Number of terminals to AUX bus</li> </ul>	0
<ul style="list-style-type: none"> <li>Number of add-on terminals</li> </ul>	0
<ul style="list-style-type: none"> <li>Number of terminals with connection to P1 and P2 bus</li> </ul>	2
Dimensions	
Width	15 mm
Height	74 mm
Depth	34 mm
Weights	
Weight, approx.	24 g

## Dimension drawings of I/O modules

Dimension drawing BU15-P16+A10+2D, BU15-P16+A10+2B, BU15-P16+A0+12D/T, BU15-P16+A0+12B/T

The figure below shows the dimension drawing of the BU15-P16+A10+2D with plugged-in I/O module as an example.

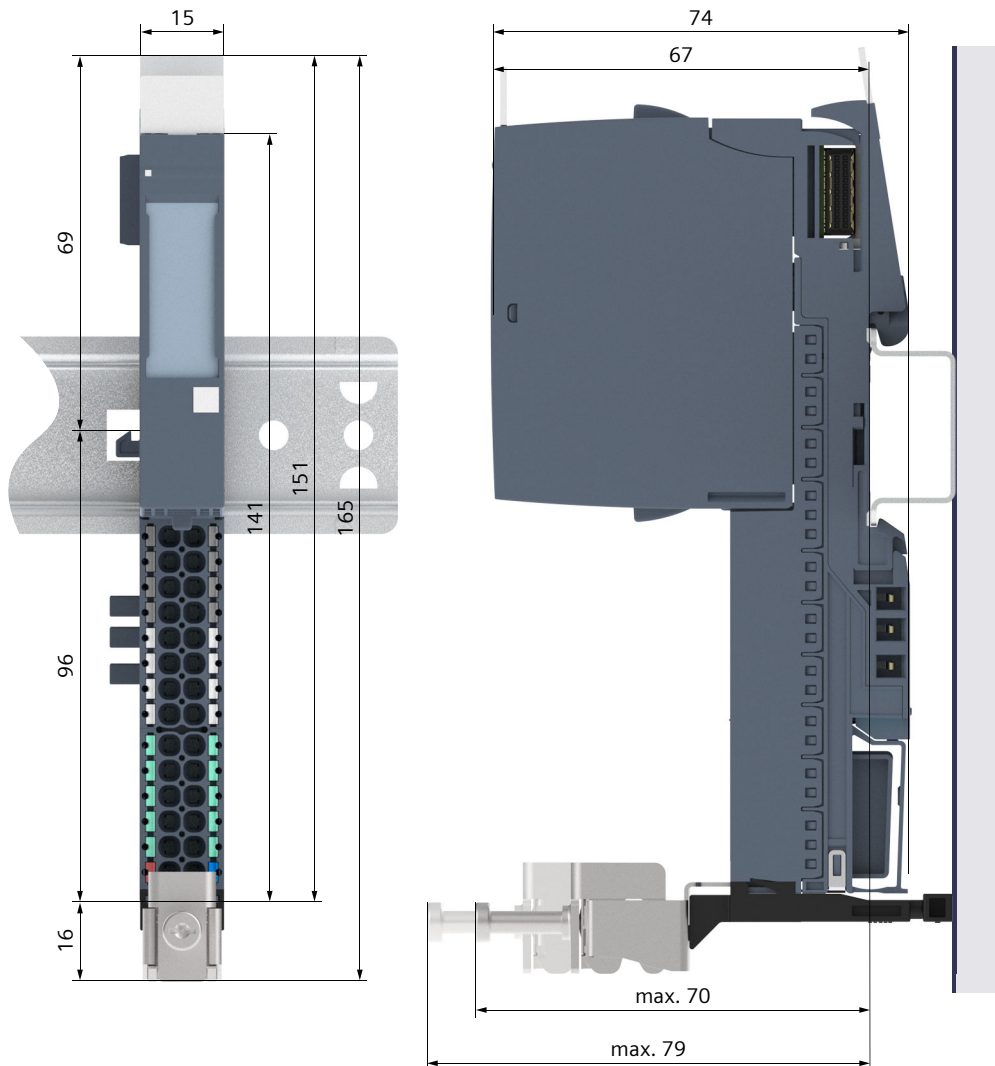

Figure A-1 Dimension drawing BU15-P16+A10+2D

**Dimension drawing BU15-P16+A0+2D, BU15-P16+A0+2B, BU15-P16+A0+2D/T, BU15-P16+A0+2B/T**

The figure below shows the dimension drawing of the BU15-P16+A0+2D with plugged-in I/O module as an example.

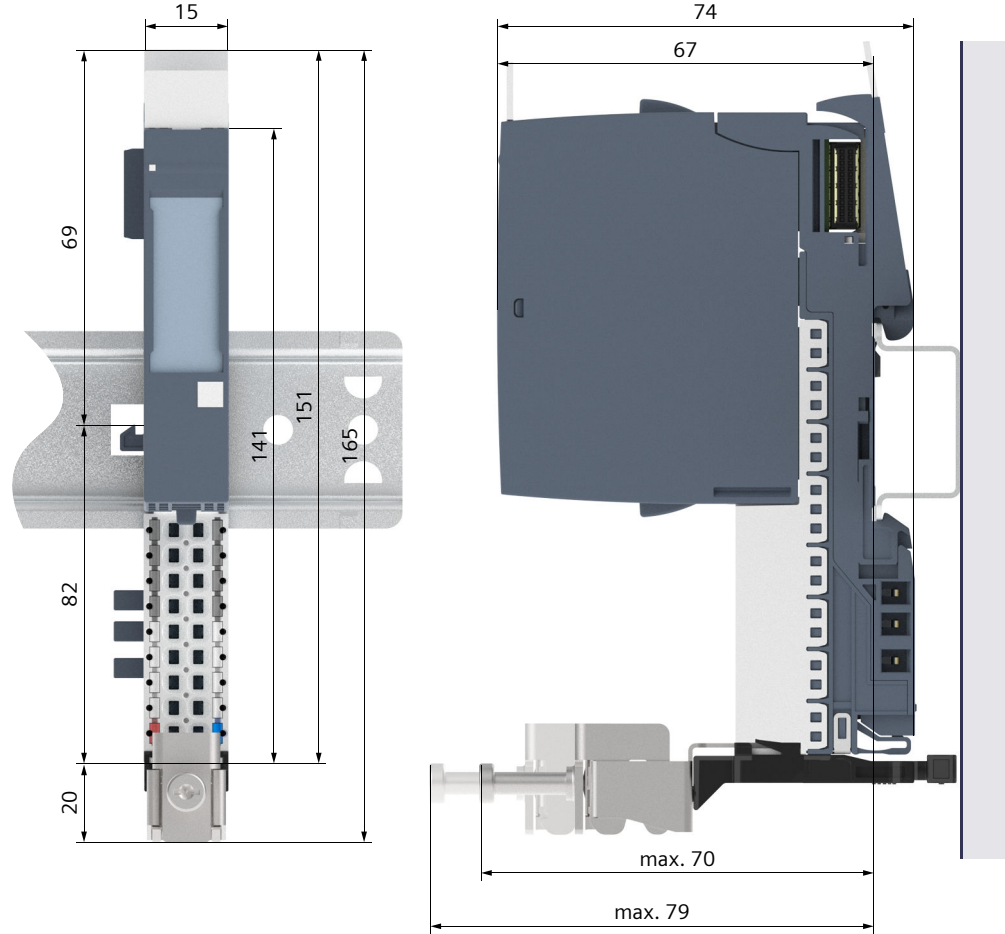

Figure A-2 Dimension drawing BU15-P16+A0+2D

**Dimension drawing BU20-P6+A2+4D, BU20-P6+A2+4B, BU20-P12+A4+0B, BU20-P12+A0+0B, BU20-P12+A0+4B, BU20-P8+A4+0B**

The figure below shows the dimension drawing of the BU20-P12+A4+0B with plugged-in I/O module as an example.

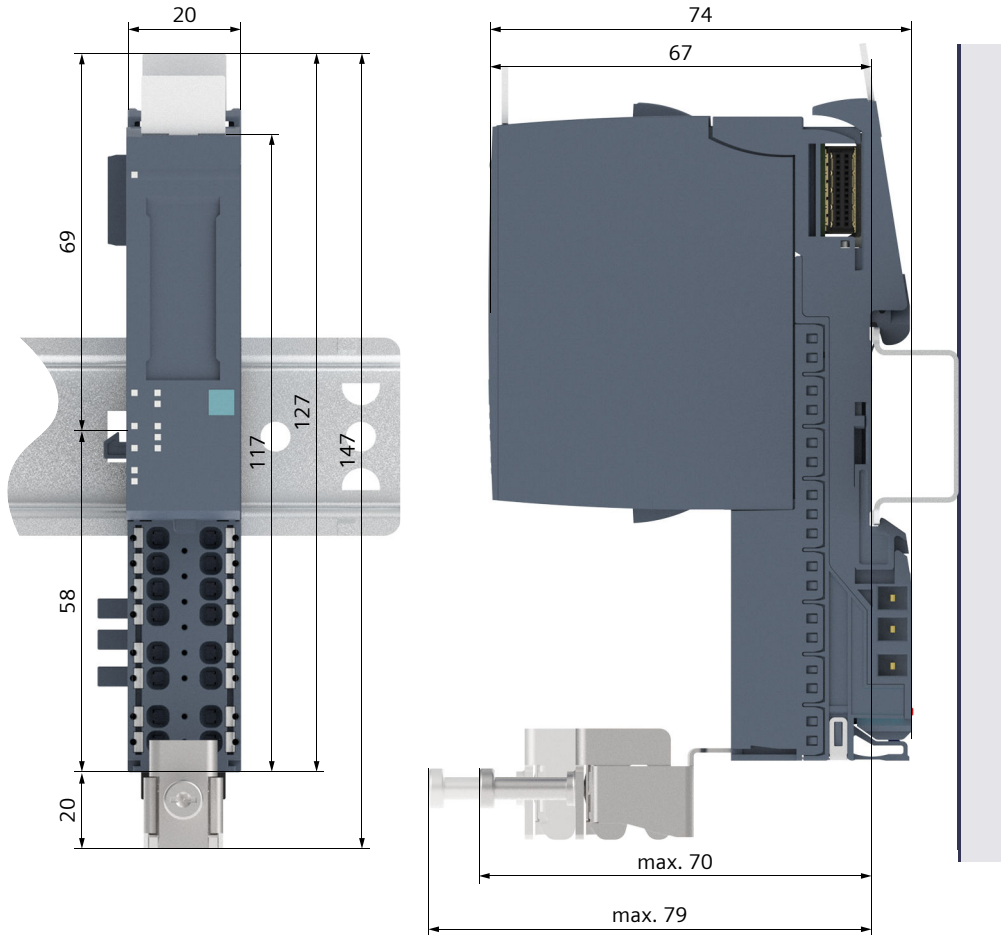

Figure A-3 Dimension drawing BU20-P12+A4+0B

**Dimension drawing test probe for measurement tap**

The figure below shows the dimension drawing of a suitable test probe for measurement tap at the BaseUnit.



Figure A-4 Dimension drawing test probe



## Dimension drawings of motor starters

Dimension drawing BU30-MS1, BU30-MS2, BU30-MS3, BU30-MS4, BU30-MS5, BU30-MS6, BU30-MS7, BU30-MS8, BU30-MS9, BU30-MS10

The figure below shows the dimension drawing of the BU30-MS-1 with plugged-in motor starter module as an example.

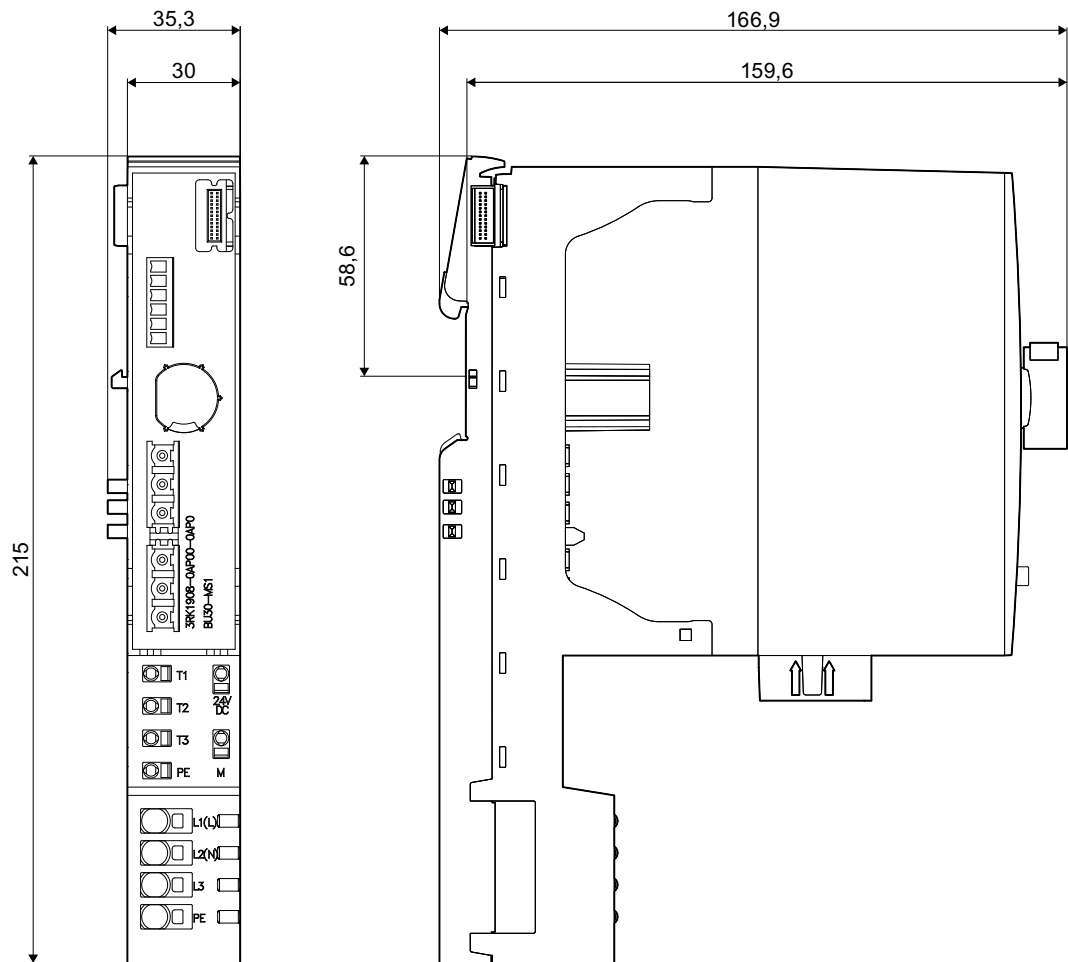

Figure B-1 Dimension drawing BU30-MS1

# Dimension drawings of the potential distributor modules

# C

## Dimension drawing

The figure below shows the dimension drawing of the PotDis-BU-P1/B-R with plugged-in PotDis-TB-P1-R terminal block.

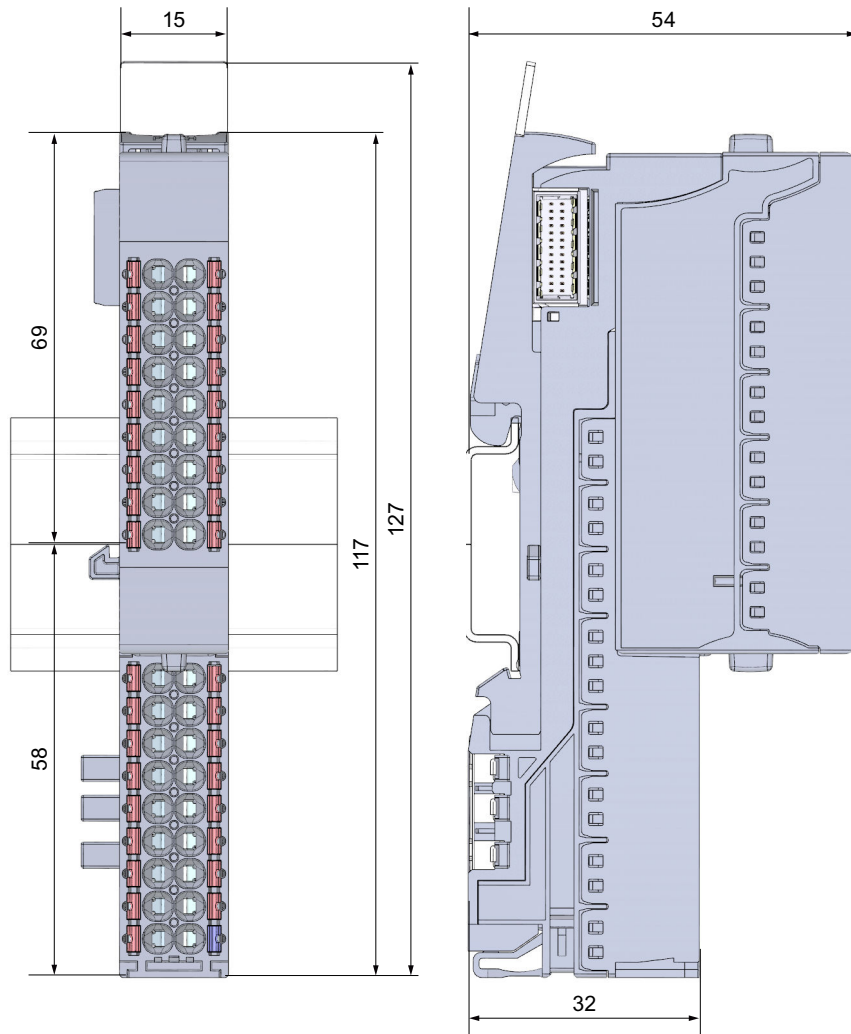

Figure C-1 Dimension drawing of PotDis BU-P1/B-R with plugged-in terminal block

# Index

## C

Changes

compared to previous version, [15](#)

## X

XE N:1 , [89](#), [89](#), [89](#), [90](#), [90](#), [90](#), [90](#), [90](#), [90](#), [90](#), [90](#),  
[90](#), [90](#), [93](#), [93](#), [93](#), [93](#), [93](#), [93](#), [93](#), [93](#), [93](#), [93](#), [93](#), [93](#),  
[93](#), [93](#), [96](#), [96](#), [96](#), [96](#), [96](#), [96](#), [96](#), [96](#), [96](#), [96](#), [96](#),  
[96](#), [96](#), [99](#), [99](#), [99](#), [99](#), [99](#), [99](#), [99](#), [99](#), [99](#), [99](#), [99](#),  
[99](#), [99](#), [102](#), [102](#), [102](#), [102](#), [102](#), [102](#), [102](#), [102](#), [102](#),  
[102](#), [102](#), [102](#), [103](#), [103](#), [103](#), [105](#), [105](#), [105](#), [105](#),  
[105](#), [106](#), [106](#), [106](#), [106](#), [106](#), [106](#), [106](#), [106](#), [106](#),  
[109](#), [109](#), [109](#), [109](#), [110](#), [110](#), [110](#), [110](#), [110](#), [110](#),  
[110](#), [110](#), [110](#), [113](#), [113](#), [113](#), [113](#), [113](#), [113](#), [113](#),  
[113](#), [113](#), [113](#), [113](#), [113](#), [113](#), [116](#), [116](#), [116](#), [116](#),  
[116](#), [116](#), [116](#), [116](#), [116](#), [116](#), [116](#), [116](#), [116](#), [116](#),  
[119](#), [119](#), [119](#), [119](#), [119](#), [119](#), [119](#), [119](#), [119](#), [119](#),  
[119](#), [119](#), [119](#)

XE T:0 , [89](#), [93](#), [96](#), [98](#), [102](#), [105](#), [109](#), [113](#), [116](#),  
[119](#)

XE TDB\_S , [89-90](#), [93](#), [96](#), [98-99](#), [102-103](#), [105-](#)  
[106](#), [109-110](#), [113](#), [116](#), [119](#)

XE U0:0 , [89](#), [90](#), [90](#), [90](#), [93](#), [93](#), [93](#), [96](#), [96](#), [96](#),  
[98](#), [99](#), [99](#), [102](#), [102](#), [102](#), [105](#), [106](#), [106](#), [109](#),  
[110](#), [110](#), [110](#), [113](#), [113](#), [113](#), [116](#), [116](#), [116](#), [119](#),  
[119](#), [119](#)