

BI10U-MT18-AP6X-H1141

Inductive Sensor

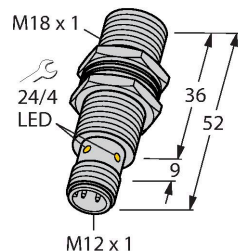

Features

- Threaded barrel, M18 x 1
- Brass, PTFE-coated
- Factor 1 for all metals
- Protection class IP68
- Resistant to magnetic fields
- Large switching distance
- DC 3-wire, 10...30 VDC
- NO contact, PNP output
- M12 x 1 male connector

Wiring diagram

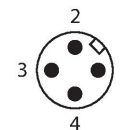
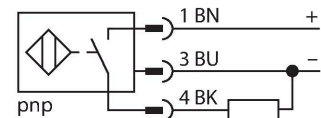

Functional principle

Inductive sensors are designed for wear-free and contactless detection of metal objects. approx3 sensors have significant advantages due to their patented multi-coil system. They excel thanks to their optimum switching distances, maximum flexibility and operational reliability as well as efficient standardization.

Technical data

Type	BI10U-MT18-AP6X-H1141
ID	1644831
General data	
Rated switching distance	10 mm
Mounting conditions	Flush
Secured operating distance	$\leq (0.81 \times S_n)$ mm
Repeat accuracy	≤ 2 % of full scale
Temperature drift	$\leq \pm 10$ %
Hysteresis	3...15 %
Electrical data	
Operating voltage	10...30 VDC
Residual ripple	≤ 10 % U_{ss}
DC rated operational current	≤ 200 mA
No-load current	25 mA
Residual current	≤ 0.1 mA
Isolation test voltage	≤ 0.5 kV
Short-circuit protection	yes / Cyclic
Voltage drop at I_o	≤ 1.8 V
Wire breakage/Reverse polarity protection	yes / Complete
Output function	3-wire, NO contact, PNP
DC field stability	300 mT
AC field stability	300 mT _{ss}
Switching frequency	1.5 kHz
Mechanical data	
Design	Threaded barrel, M18 x 1
Dimensions	52 mm

Technical data

Housing material	Metal, CuZn, PTFE-coated
Active area material	Plastic, LCP, PTFE-coated
Max. tightening torque of housing nut	10 Nm
Electrical connection	Connector, M12 × 1
Environmental conditions	
Ambient temperature	-25...+70 °C
Vibration resistance	55 Hz (1 mm)
Shock resistance	30 g (11 ms)
Protection class	IP68
MTTF	874 years acc. to SN 29500 (Ed. 99) 40 °C
Switching state	LED, Yellow

Mounting instructions

Mounting instructions/Description

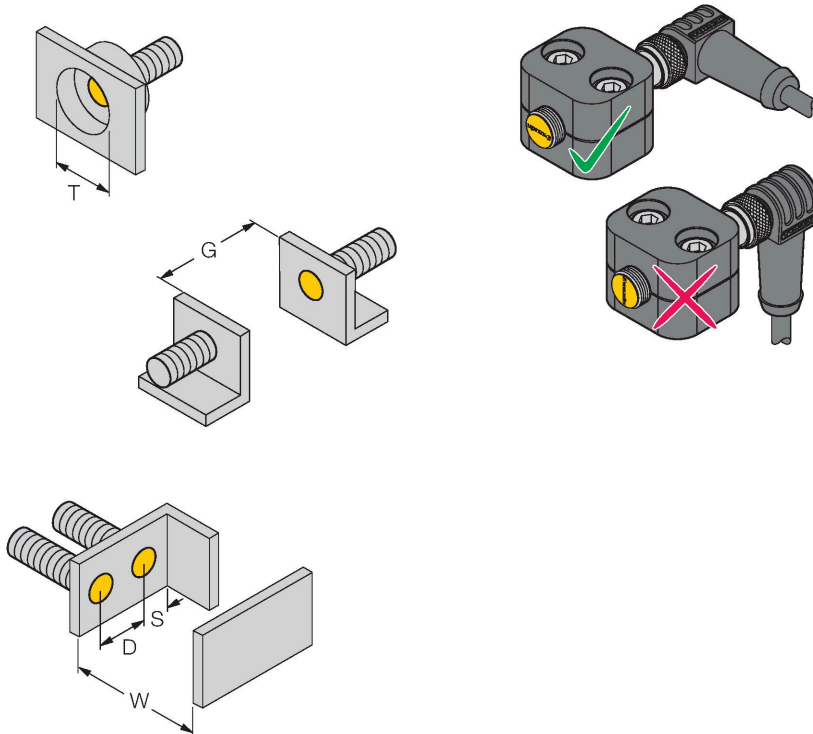

Distance D	36 mm
Distance W	3 x Sn
Distance T	3 x B
Distance S	1.5 x B
Distance G	6 x Sn
Diameter active area B	Ø 18 mm

When installing the sensor in combination with the illustrated half-shell-clamp, observe its correct alignment towards the clamp. For this, see the uprox-letting on the front cap of the sensor and the adjacent installation drawing.

Accessories

BST-18B

6947214

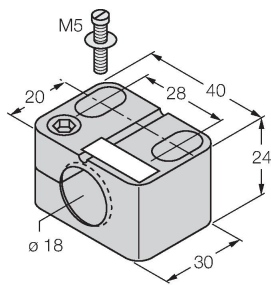

Mounting clamp for threaded barrel sensors, with dead-stop; material: PA6

BSS-18

6901320

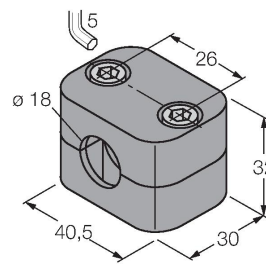

Mounting clamp for smooth and threaded barrel sensors; material: Polypropylene

Accessories

Dimension drawing

Type

ID

RKC4T-2/TXL1001

6630249

Connection cable, M12 connector, female, straight, 3-pin, cable length: 2 m, protective sheathing material: Aramid fibers, yellow; Temperature peak: 200 °C; other cable lengths and qualities available, see www.turck.com

