

HEAVY DUTY ROTARY INDEXING TABLE CR2000C

MOUNTING INSTRUCTIONS

TD0033A-EN00-0000-00

102017_1.0_EN

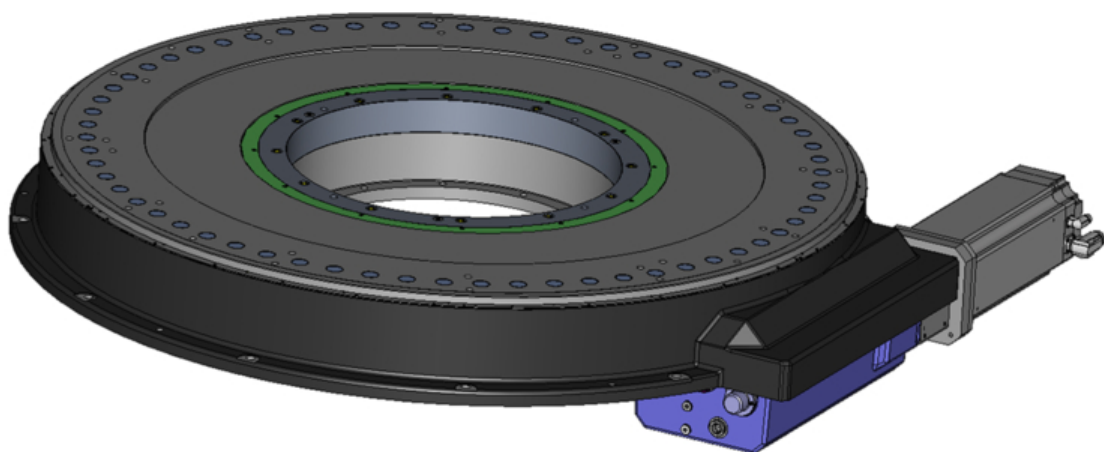

Table of contents

1	Introduction.....	4
1.1	About these mounting instructions.....	4
1.2	Intended use.....	4
1.3	Predictable incorrect application.....	5
1.4	Applicable documents.....	5
2	Safety.....	6
2.1	Safety messages and hazard categories.....	6
2.2	Hazard symbols.....	7
2.3	Responsibilities of the system integrator and/or operator.....	7
2.4	Qualification of personnel.....	8
2.5	Personal protective equipment.....	8
3	Product description.....	9
3.1	Overview.....	9
3.2	Function description.....	10
3.3	Nameplate.....	10
3.4	Type code.....	11
3.5	Mounting positions.....	11
4	Technical data.....	12
4.1	Technical data "Heavy Duty Rotary Indexing Table".....	12
4.2	Technical data "Motor and Holding Brake".....	12
4.3	Electrical connections.....	12
4.4	Climatic environmental conditions "Operation".....	13
4.5	Climatic environmental conditions "Transportation and Storage".....	13
4.6	Dimensions.....	14
4.7	Load data.....	15
5	Controller.....	16
5.1	Basic information on control.....	16
5.2	WEISS GmbH controller/software package (optional).....	16
6	Packaging, transportation and storage.....	17
6.1	Verification of the delivery.....	17
6.2	Packaging and shipment.....	17
6.3	Unpacking the product.....	17
6.4	Transportation.....	18
6.5	Storage.....	18
7	Mounting.....	20



7.1	Prerequisites for mounting.....	20
7.2	Mounting the product.....	20
7.2.1	Equipment and tools.....	20
7.2.2	Tightening torques and property classes.....	20
7.2.3	Bolting down the product.....	21
7.2.4	Mounting additional components.....	22
7.2.5	Mounting safety equipment.....	23
7.3	Electrical connection.....	25
8	Commissioning.....	26
8.1	Prerequisites for commissioning.....	26
8.2	Performing commissioning.....	26
8.3	Setting the zero point.....	28
9	Operation.....	29
9.1	Basic information on operation.....	29
10	Troubleshooting.....	30
10.1	Issue, cause and remedy.....	30
11	Cleaning.....	32
11.1	Performing cleaning.....	32
12	Maintenance.....	34
12.1	Maintenance plan.....	34
12.2	Lubricant.....	34
12.3	Dismounting the motor and the metal bellows coupling.....	34
12.4	Mounting the motor and the metal bellows coupling.....	38
13	Decommissioning.....	40
13.1	Decommissioning the product.....	40
14	Dismounting.....	41
14.1	Dismounting the product.....	41
15	Disposal.....	41
15.1	Disposing of the product.....	41
16	Service and spare parts.....	42
16.1	Service.....	42
16.2	Ordering spare parts.....	42
17	Warranty.....	43
17.1	Information on warranty.....	43

1 Introduction

1.1 About these mounting instructions

These mounting instructions describe the product Heavy duty rotary indexing table CR2000C (also referred to as "product" in this document).

These mounting instructions are part of the product.

- You may only use the product if you have fully read and understood these mounting instructions.
- Verify that these mounting instructions are always accessible for any type of work performed on or with the product.
- Pass these mounting instructions as well as all other product-related documents on to all owners of the product.
- If you feel that these mounting instructions contain errors, inconsistencies, ambiguities or other issues, contact the manufacturer prior to using the product.

These mounting instructions are protected by copyright and may only be used as provided for by the corresponding copyright legislation. We reserve the right to modifications.

The manufacturer shall not be liable in any form whatsoever for direct or consequential damage resulting from failure to observe these mounting instructions or from failure to comply with directives, regulations and standards and any other statutory requirements applicable at the installation site of the product.

1.2 Intended use

The product is a partly complete machine pursuant Directive 2006/42/EU, articles 1g and 2g. The product is only intended to be incorporated into or assembled with other machinery or other partly completed machinery or equipment, thereby forming machinery to which Directive 2006/42/EU applies.

The product may only be used within the limits specified in these mounting instructions and in the applicable documents. The applicable documents are also part of the product.

The machinery must not be put into service until the machinery into which the product has been incorporated has been determined and declared in conformity with the provisions of Directive 2006/42/EU and with all other applicable directives and regulations.

In addition, perform a risk assessment in view of the planned application, according to an approved risk assessment method, and implement the appropriate safety measures, based on the results of the risk assessment. Take into account the consequences of installing or integrating the product into a system or a plant.

When using the product, perform all work and all other activities in conjunction with the product in compliance with the conditions specified in the mounting instructions, in the applicable documents, and on the nameplate, as well as with all directives, standards, and safety regulations applicable at the installation site of the product.

1.3 Predictable incorrect application

Any use of the product beyond the explicitly indicated intended use is an impermissible, incorrect application of the product.

The product must never be used in the following cases, und the following conditions, and for the following purposes:

- Operation of the product in potentially explosive atmospheres/hazardous areas

1.4 Applicable documents

In addition to these mounting instructions, the following documents are binding for and apply to any type of use of the product:

- Order data (including, but not limited to, design data, load data, performance data, transportation and storage instructions, information attached to the product and the package, as well as other specifications).
- Operating instructions and mounting instructions of all products belonging to the scope of delivery (for example, motor, accessories, attachment parts). This includes, among other things:

Type of manual	Type	Manufacturer
Operating instructions	Various motors	SEW EURODIRVE
User manual	Threephase synchronous motors 8LS	B&R Industrial Automation GmbH
In the case of delivery with WEISS GmbH controller/software package:		
Electrical documentation	List of applicable documents, per product (see documents on the CD delivered with the product)	WEISS GmbH

2 Safety

2.1 Safety messages and hazard categories

These mounting instructions contain safety messages to alert you to potential hazards and risks. Safety messages in these mounting instructions are highlighted with warning symbols and warning words.

The signal word describes the source of the hazard. The text contains instructions on how to avoid the hazard as well as the consequence resulting from failure to follow the instructions given in the safety message.

Depending on the severity of a hazard, the safety messages are classified according to different hazard categories.

DANGER

DANGER indicates an immediately hazardous situation, which, if not avoided, will result in death or serious injury.

WARNING

WARNING indicates a hazardous situation, which, if not avoided, can result in death or serious injury or equipment damage.

CAUTION

CAUTION indicates a hazardous situation, which, if not avoided, can result in injury or equipment damage.

NOTICE

NOTICE indicates a hazardous situation, which, if not avoided, can result in equipment damage.

In addition to the instructions and safety messages provided in these mounting instructions, you must comply with all directives, standards, and safety regulations applicable at the installation site of the product.

2.2 Hazard symbols

The following symbols are used in these mounting instructions:



This is the general safety alert symbol. It alerts to injury hazards or equipment damage. Comply with all safety instructions in conjunction with this symbol to help avoid possible death, injury, or equipment damage.



This symbol alerts to hazardous electrical voltage. If this symbol is used in a safety message, there is a hazard of electric shock.

Hazard symbols may also be attached to the product.



Hazard of hot surface



Hazard of magnetic field



Hazard of injury to hand



No access for persons with heart pacemakers or other medical implants

2.3 Responsibilities of the system integrator and/or operator

The system integrator (the person who incorporates the product in a machine pursuant to Directive 2006/42/EU, i.e., for example, the machine builder) and/or the operator must ensure the following:

- The application and use of the product must be limited to the specified intended use.
- In the integration of the product, all functional safety requirements must be met.
- All directives, standards, and safety regulations, including all regulations concerning workplace safety and prevention of accidents, applicable at the installation site of the product must be complied with.
- Any type of work whatsoever on and with the product may only be performed by qualified personnel.
- The product may only be operated when it is in flawless, fully functional condition.
- All safety equipment must operate as required and planned.
- The personal protective equipment for the personnel/operator must be available and must be used.
- The mounting instructions and all applicable documents must always be accessible in their entirety to the personnel at the installation site of the product.
- Safety instructions, labels, and any other information attached to the product must not be removed.
- A complete manual must be available for the machine into which the product is incorporated; this manual must describe all types of work on and with the machine and contain all information relevant with regard to the product.

If the system integrator himself is not in the position to comply with any of these obligations, the system integrator must impose compliance with these obligations on the operator.

2.4 Qualification of personnel

Only trained personnel who have fully read and understood the mounting instructions and all applicable documents for the product may perform work on and with the product.

This trained personnel must have sufficient technical training, knowledge, and experience, and be able to foresee and detect potential hazards that may be caused by using the product.

All trained personnel working on and with the product must be fully familiar with all directives, standards, and safety regulations that must be observed for performing such work.

2.5 Personal protective equipment

Always wear the required personal protective equipment.

When performing work on and with the product, take into account that hazards may be present at the installation site which do not directly result from the product itself.

When performing any type of work on or with the product, wear non-slip protective shoes, protective goggles, and tight clothing.

3 Product description

3.1 Overview

The product consists of the following components:

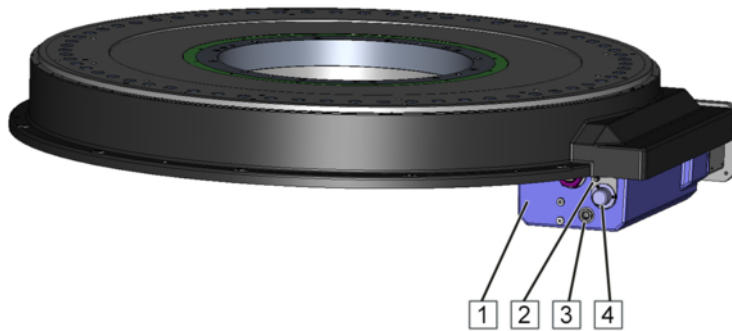

- | | |
|--------------------------------------------------------|-------------------------------------------------------------------------------|
| <p>1 Cam housing</p> <p>2 Vent screw</p> | <p>3 Oil sight glass</p> <p>4 Cover of shaft for hand crank</p> |
|--------------------------------------------------------|-------------------------------------------------------------------------------|

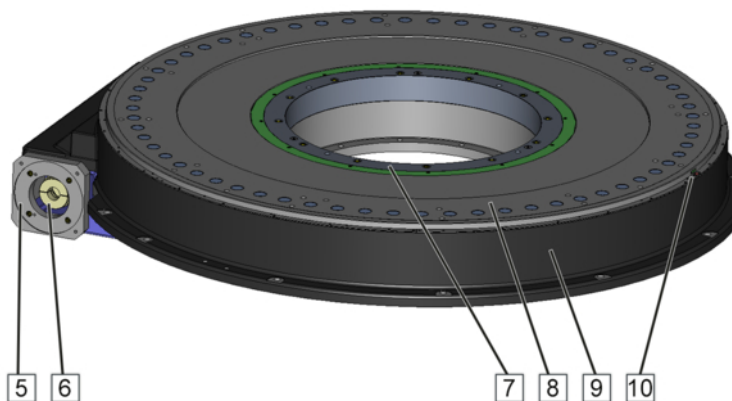

- | | |
|------------------------------------------------------------------------------------------------------------|-------------------------------------------------------------------------------------------------------------------------|
| <p>5 Motor flange</p> <p>6 Metal bellows coupling</p> <p>7 Stationary center part</p> | <p>8 Output flange</p> <p>9 Housing heavy duty rotary indexing table</p> <p>10 Zero point mark</p> |
|------------------------------------------------------------------------------------------------------------|-------------------------------------------------------------------------------------------------------------------------|

3.2 Function description

The output flange of the motor is driven by a servo motor via a gear and the driving cam. The servo motor is controlled by a servo drive according to a programmable motion profile and rotates, accelerates or decelerates the output flange of the product.

The output flange can rotate left, right or alternatingly.

The signals for position control of the output flange are generated by an encoder (absolute encoder) integrated in the motor.

The electromechanical holding brake holds the output flange in position when it is at a standstill. The holding brake is released by applying the brake voltage.

3.3 Nameplate

The nameplate is attached to the housing of the product; it contains the following information:



Figure 1: Example of nameplate

- | | |
|----------------------------|----------------------------|
| 1. Type | 6. Year of manufacture |
| 2. Serial number | 7. Weight |
| 3. Gear ratio | 8. QR code company website |
| 4. Input speed of rotation | 9. DM code serial number |
| 5. Input torque | |

The scope of delivery contains a second nameplate. If the factory-mounted nameplate is covered by attachments, the second nameplate can be attached at a readily visible position of the product or machine for identification of the product.

3.4 Type code

Structure of the type code:

Type	Size	Version	Encoder system	Gear stage	Motor
CR	2000	C	- (Without)	A (310:1)	A (Standard) X (Special) - (Without)

3.5 Mounting positions

NOTICE
<p>OIL LOSS OR DRY RUN DUE TO INCORRECT MOUNTING POSITION</p> <ul style="list-style-type: none"> ▪ Verify that you only use the standard mounting positions approved in these mounting instructions. ▪ Only use special mounting positions if such special mounting positions have been approved by the manufacturer in writing. <p>Failure to follow these instructions can result in equipment damage.</p>

Permissible standard mounting positions

The product may only be mounted as shown below.

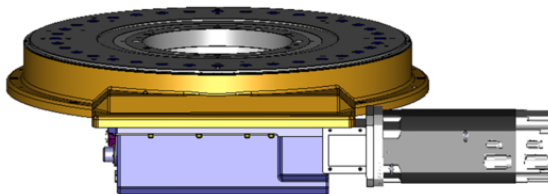

Axis of rotation vertical

4 Technical data

4.1 Technical data "Heavy Duty Rotary Indexing Table"

Characteristic	Dimension	Unit	Value
Maximum speed of rotation of motor	$n_{1 \max}$	1/min	2000
Maximum output speed of rotation	$n_{2 \max}$	1/min	6.5
Total gear ratio	i_{tot}	-	310:1
Indexing accuracy	-	arcsec	20 (± 10)
Maximum axial runout output flange	$A_r \varnothing_{1874}$	mm	0.03
Maximum radial runout output flange	C_r	mm	0.03
Weight with motor	m	kg	Approximately 3600
Total weight including packaging	-	kg	See bill of delivery
Lubricant	-	-	Shell Omala S2 G ISO VG 680
Lubricant volume	-	l	8

4.2 Technical data "Motor and Holding Brake"

See the documentation of the manufacturer for the technical data of the motor and the holding brake, [see chapter](#).

Characteristic	Value
Supply voltage motor	See order confirmation
Supply voltage holding brake	See order confirmation
Vibration resistance*	See operating instructions of motor manufacturer
Shock resistance*	See operating instructions of motor manufacturer

* The information on vibration resistance and shock resistance also apply to operation, transportation, and storage of the product.

4.3 Electrical connections

See the documentation of the manufacturer for the technical data of the electrical connections, [see chapter](#).

4.4 Climatic environmental conditions "Operation"

Characteristic	Unit	Value
Ambient temperature	°C	+10 ... +40
Relative humidity, non-condensing	%	< 50
Maximum surface temperature	°C	100
Maximum installation altitude above mean sea level	m	1000

4.5 Climatic environmental conditions "Transportation and Storage"

Characteristic	Unit	Value
Ambient temperature	°C	+5 ... +60
Relative humidity, non-condensing	%	< 50
Maximum storage duration of the mechanical components	-	see chapter 6.5

4.6 Dimensions

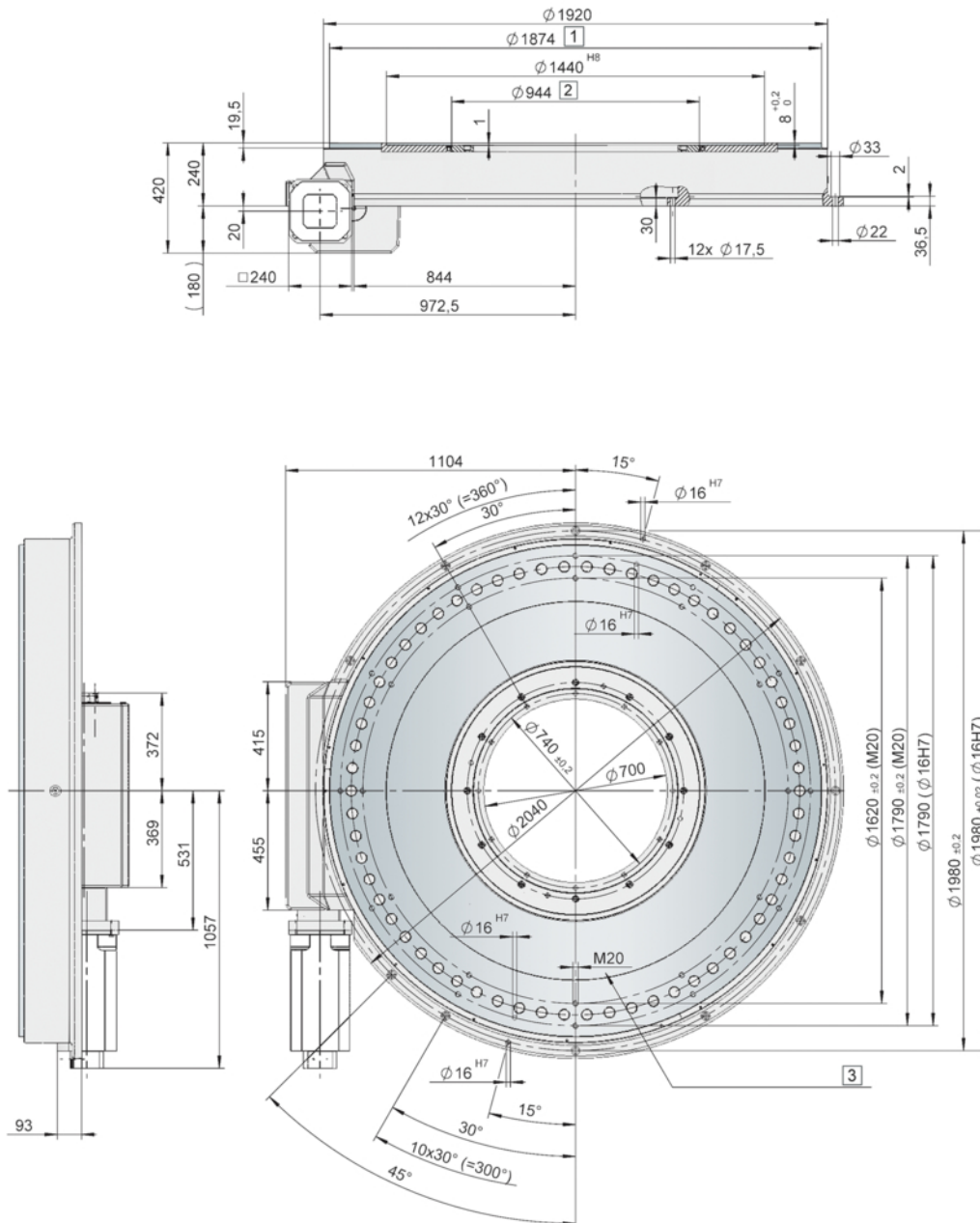

Figure 2: Lengths and diameters in mm

- 1 Rotating part
- 2 Stationary part
- 3 Maximum engagement depth 32 mm

4.7 Load data

Load data for output flange

Characteristic	Dimension	Unit	Value
Permissible dynamic moment of tilt	$M_{2T \text{ dyn}}$	Nm	55000
Permissible dynamic axial force	$F_{2A \text{ dyn}}$	N	250000
Permissible dynamic radial force	$F_{2R \text{ dyn}}$	N	125000

5 Controller

5.1 Basic information on control

WARNING

LOSS OF CONTROL

- Consider all potential failure modes of all control paths in your control concept.
- Implement means and measures for all critical functions to achieve a safe state if a control path fails (for example, emergency stop, overtravel of positions, power outage, and restart).
- Implement separate or redundant control paths for all critical functions.
- If the control system of the machine comprises communication links, consider the consequences of unanticipated transmission delays or failures of the link and implement appropriate measures.
- Subject each machine in which the product described in these mounting instructions is used to a comprehensive and thorough commissioning test before operating the machine.

Failure to follow these instructions can result in death, serious injury, and equipment damage.

The output flange can be operated with the following directions of movement: left, right, or alternating.

A movement of the output flange is started by sending a start signal to the motor and applying the holding brake voltage. This releases the holding brake and the motor accelerates.

To stop the movement of the output flange, a stop signal is sent to the motor and the motor decelerates to a standstill. After the motor has decelerated to a standstill, the supply voltage to the holding brake is removed. This applies the holding brake.

The controller determines the cycle. The required signals for the motor and the holding brake are generated by means of the encoder (absolute encoder) of the servo motor.

5.2 WEISS GmbH controller/software package (optional)

WEISS GmbH offers a controller/software package for controlling the product in conjunction with B&R motors.

If this option is used, you must follow all instructions in the corresponding instruction manual, [see chapter](#).

6 Packaging, transportation and storage

6.1 Verification of the delivery

- Check the delivery for completeness and transportation damage upon reception.
- In the case of damage, reject the delivery or accept it only conditionally.
- Document the damage in the transportation documents/bill of delivery (any damage detected must be immediately reported to the forwarding agent and confirmed by the forwarding agent).
- Take photographs of the damage.
- Report the damage to WEISS GmbH.

6.2 Packaging and shipment



Packaging in Europe

The product is factory-treated with anti-corrosion agent, packaged in film and screwed onto a palette.



Packaging for air and sea freight

The product is factory-treated with anti-corrosion agent, packaged in Corpac-Cotex-VCI film, screwed onto a palette, and then packed into a wooden box with foam plastic material.

Packaging of electrical components

The electrical components are packaged in special cardboard boxes.

6.3 Unpacking the product

1. Do not remove the packaging until immediately prior to mounting.
2. Dispose of the packaging material in compliance with all directives, standards, and safety regulations applicable at the installation site.

6.4 Transportation

WARNING

FALLING, TOPPLING, OR LOWERING LOADS

Insufficiently rated load lifting and handling equipment may break. Transportation vehicles, lifting gear, chains, belts, and other equipment not rated for the product may fail or tilt.

- Only use transportation vehicles, lifting gear, chains, belts, and other lifting and handling equipment that comply with all applicable regulations and that are rated for the weight of the product including packaging.
- Verify that there are no persons in the danger zone.
- Verify that the product is properly secured against falling and toppling.

Failure to follow these instructions can result in death, serious injury, and equipment damage.

Observe the maximum engagement thread for the load lifting and handling equipment [see chapter 4.6](#).

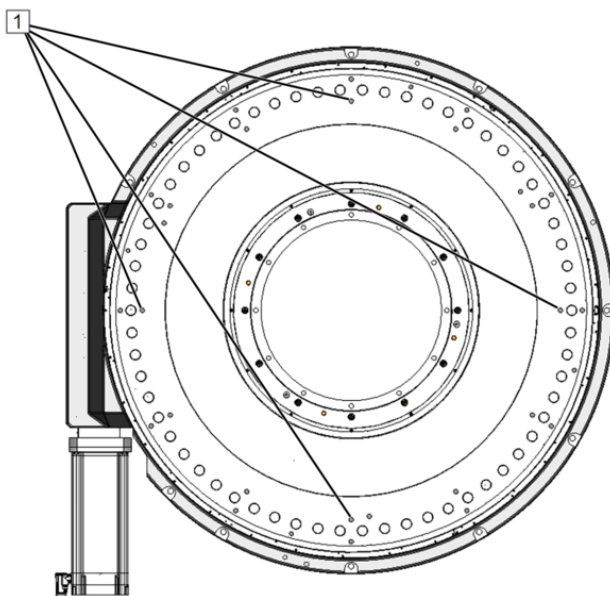

1. Use properly rated load lifting and handling equipment and hoisting belts for transporting the product.
2. Screw the load lifting and handling equipment (M20) into the threads [1] in the output flange.
3. Fasten the hoisting belts or the hoisting equipment to the eyelets of the load lifting or load handling equipment.

6.5 Storage

NOTICE

INCORRECT STORAGE

- Verify compliance with all conditions specified in these mounting instructions and all applicable documents when storing the product.

Failure to follow these instructions can result in equipment damage.

The mechanical components can be stored for a period of up to two years.

Conditions for the specified maximum storage duration:

- Storage in original packaging
- Compliance with all specified storage conditions
- Storage in suitable closed, dry, dust-free room, protected against direct sunlight
- No contact with corrosive media
- Compliance with specifications regarding vibration resistance and shock resistance, [see chapter 4.2](#)
- Corrosion protection intact

The electrical components must be stored according to the specifications of the manufacturers (see operating instructions of the manufacturers).

If the maximum storage duration has been exceeded, you must contact the manufacturer prior to commissioning the product. This also applies if the machine in which the product has been incorporated has not been operated for a period of time exceeding the maximum storage durations specified for the mechanical and electrical components.

If you plan to store the product for a period of time exceeding the maximum permissible storage duration specified for the mechanical components, you must uninstall the electrical components prior to storing the product, [see chapter 12](#).

If the product is to be stored for a period of more than three months, the product must first be preserved. If the factory-applied anti-corrosion agent is no longer intact, you must request preservation instructions from the manufacturer.

7 Mounting

7.1 Prerequisites for mounting

Motor and holding brake must remain accessible for service and maintenance work.

Prior to mounting, the anti-corrosion and any pollution must be removed with a standard solvent.

NOTICE

DAMAGE TO SHAFT SEALING RINGS

- Avoid any contact of the sealing lips of the shaft sealing rings with the solvent.

Failure to follow these instructions can result in equipment damage.

Prior to mounting, verify that the dimensions of the installation site and construction conditions meet the requirements and the dimensions specified in these mounting instructions and the applicable documents.

- Verify that the supporting base is level and rigid.
 - Maximum permissible flatness error: 0.1 mm
- Verify that the supporting structure at the installation site has a sufficient structural strength to carry the weight of the product and of all loads.
- Verify that the motor is easily accessible for service and maintenance work.
- Verify that there is a minimum distance of 100 mm between the motor fan (if the motor is equipped with a fan) and other assemblies.
- Verify that free convection for removing the hot air is not obstructed.

7.2 Mounting the product

7.2.1 Equipment and tools

The following is required for mounting:

- 1 x set wrenches
- 1 x set of hex keys
- 1 x torque wrench
- 1 x set screwdrivers
- Standard solvent
- Tapered punch for mounting the parallel pins
- Parallel pins as per holes
- Screws of property class 10.9 (coefficient of friction $\mu_{\text{tot.}}$ 0.12)

7.2.2 Tightening torques and property classes

Only use screws with the property class shown in the following table unless a different property class is explicitly specified for a screw connection.

Use the tightening torque shown in the following table unless a different tightening torque is explicitly specified for a screw connection.

Property class of screws	10.9 (coefficient of friction $\mu_{\text{tot.}}$ 0.12)				
Thread	M8	M10	M12	M16	M20
Tightening torque	34 Nm	68 Nm	117 Nm	285 Nm	557 Nm

7.2.3 Bolting down the product

WARNING

FALLING, TOPPLING, OR LOWERING LOADS

Insufficiently rated load lifting and handling equipment may break. Transportation vehicles, lifting gear, chains, belts, and other equipment not rated for the product may fail or tilt.

- Only use transportation vehicles, lifting gear, chains, belts, and other lifting and handling equipment that comply with all applicable regulations and that are rated for the weight of the product including packaging.
- Verify that there are no persons in the danger zone.
- Verify that the product is properly secured against falling and toppling.

Failure to follow these instructions can result in death, serious injury, and equipment damage.

WARNING

IMPROPERLY FASTENED PARTS

- Verify that the supporting structure and/or the frame and/or the mounting surface for fastening the product are sufficiently rated to withstand all static and dynamic loads and forces during operation.
- Verify that the fastening parts comply with the specifications indicated and that they are sufficiently rated for all loads during operation.

Failure to follow these instructions can result in death, serious injury, and equipment damage.

When determining the length of the screws, take into account the loads and forces acting in your application as well as the characteristics of the supporting structure to which the product is mounted.

Fastening screws M20, property class and tightening torques of the screw connection, [see chapter 7.2.2](#).

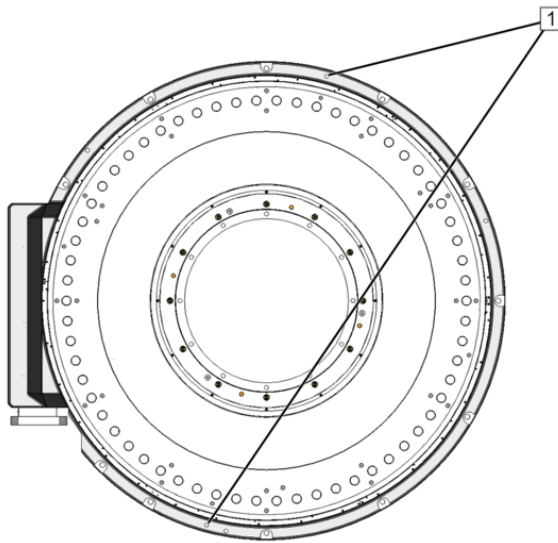

1. Place the product at the mounting site in compliance with the transportation instructions and align it according to the pin holes [1] and the holes [2].
2. Center the product with the parallel pins via the pin holes [1] and then drive in the first parallel pin by one third.
3. Screw the screws into the holes [2].
4. Slightly tighten the screws.
5. Drive all parallel pins into the pin holes [1] (positive fit, the parallel pin must be in contact with the housing of the indexing table and the mounting plate/mounting surface).
6. Tighten the screws in the holes [2] cross-wise.

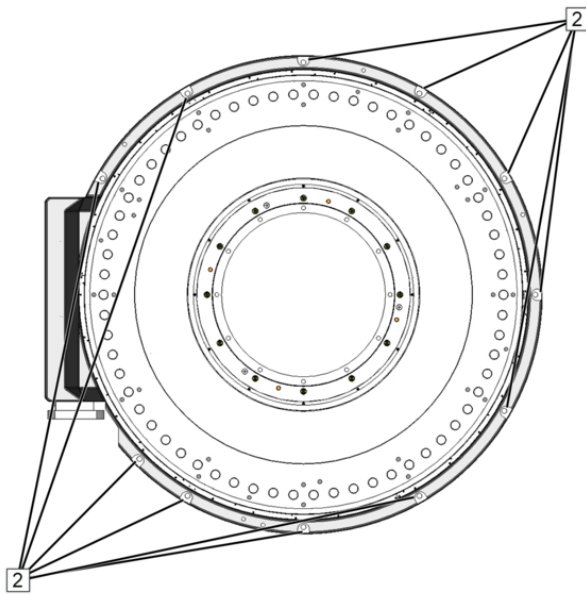

7.2.4 Mounting additional components

WARNING

IMPROPERLY FASTENED PARTS

- Verify that the supporting structure and/or the frame and/or the mounting surface for fastening the product are sufficiently rated to withstand all static and dynamic loads and forces during operation.
- Verify that the fastening parts comply with the specifications indicated and that they are sufficiently rated for all loads during operation.

Failure to follow these instructions can result in death, serious injury, and equipment damage.

WARNING**INCORRECT USE AND/OR FASTENING OF ADDITIONAL COMPONENTS**

- Only mount components to the output flange that are approved by the manufacturer.
- Only use existing holes in the output flange for mounting additional components to the output flange.
- Do not drill holes into the output flange.
- Do not attach further parts to the output flange (for example, by means of welding) to mount additional components.

Failure to follow these instructions can result in death, serious injury, and equipment damage.

NOTICE**BLOCKING OF THE PRODUCT DUE TO EXTRANEIOUS OBJECTS**

Mounting an additional indexing plate or an attachment plate creates a gap through which extraneous objects can get into the product.

- Mount a suitable lip seal between the rotating plate and the stationary plate.
- Verify that the lip seal does not collide with the existing holes.

Failure to follow these instructions can result in equipment damage.

Mounting the rotary plate

A rotary plate may only be mounted via the fit holes or threads.

If there is a centering collar at the stationary center part of the product, this centering collar must not be used to fasten an additional indexing plate.

For this reason, the center hole of a rotary plate must be approx. 2 mm larger than the centering collar. When determining the length of the screws, take into account the loads and forces acting in your application as well as the characteristics of the supporting structure to which the product is mounted.

1. Fit the rotary plate.
2. Center the parallel pins and then drive in the first parallel pin by one third of the way.
3. Screw in the screws and tighten them.
4. Fully drive in the second parallel pin.
5. Fully drive in the first parallel pin.
6. Tighten the screws cross-wise with a tightening torque suitable for the application.
7. Set the zero point.

7.2.5 Mounting safety equipment

The product is a partly complete machine pursuant Directive 2006/42/EU and intended to be incorporated into or assembled with other machinery. The requirements concerning functional safety and the corresponding safety equipment result from the risk analysis and the risk assessment for the final machine or plant.

Selection, mounting, installation, commissioning, operation and maintenance of the safety equipment must be performed by the system integrator (the person who incorporates the product in a machine pursuant to Directive 2006/42/EU, i.e., for example, the machine builder) and/or the operator.



The product requires at least the following safety equipment:

- EMERGENCY STOP system as per IEC 60204-1 / ISO 13850
- Lockable main switch to interrupt the complete power supply to all electrical components of the product

7.3 Electrical connection

DANGER

ELECTRIC SHOCK CAUSED BY LIVE PARTS

- Disconnect the mains voltage supply before performing the work and ensure that it cannot be switched on.
- Verify that no hazards can be caused by electrically conductive objects.
- Verify that all cables for the power supply are disconnected from power.
- Verify that all electrical connections are made to the specifications in the wiring diagrams.

Failure to follow these instructions will result in death or serious injury.

DANGER

ELECTRIC SHOCK DUE TO MISSING COVERS

- Verify that all removed covers are re-installed and all terminal boxes are closed after you have performed work.

Failure to follow these instructions will result in death or serious injury.

WARNING

UNANTICIPATED MOVEMENT

Interchanging the motor connections inverts the direction of rotation of the motor.

- Verify correct wiring and connection of all electrical connections.

Failure to follow these instructions can result in death, serious injury, and equipment damage.

CAUTION

IMPROPERLY INSTALLED CABLES

- Verify that the cables are correctly routed.
- Verify compliance with the bend radius specifications for the cables.
- Only use cables with the correct cross sections.
- Verify that the terminal connections are made correctly.

Failure to follow these instructions can result in injury or equipment damage.

The following components must be connected for the motor:

- Lockable main switch
- Suitable EMERGENCY STOP equipment (as per EN 60204-1 / EN ISO 13850)

8 Commissioning

8.1 Prerequisites for commissioning

The following requirements must be met before the product may be commissioned:

- The product is properly mounted.
- The electrical equipment for the power supply of the motor and the holding brake is mounted correctly.
- All cables including the protective ground conductors are properly routed and connected.
- All electrical connections have been made properly.
- All parts of the system are properly grounded in compliance with directives, regulations, and standards.
- All safety equipment and EMERGENCY-STOP circuits are operational.
- The drive is not damaged and not blocked.
- All environmental conditions are respected.
- All protective covers are properly mounted.
- All tools, equipment, and other objects have been removed from the zone of operation of the product.
- All hazards are excluded.

Prior to commissioning, perform a test for each prerequisite mentioned and verify compliance with all information and specifications contained in these mounting instructions, in all applicable documents, and in all applicable directives, regulations, and standards.

8.2 Performing commissioning

WARNING

UNANTICIPATED MOVEMENT

Incorrect connections or external influences on electrical equipment can cause unanticipated movements.

- Verify correct wiring.
- Verify that there are no persons or obstacles in the danger zone of the product before starting the product.
- Perform initial test movements without loads and without other processing units.
- Verify that all safety equipment and EMERGENCY STOP circuits are activated prior to commissioning.

Failure to follow these instructions can result in death, serious injury, and equipment damage.

 **WARNING****UNINTENDED EQUIPMENT OPERATION**

Incorrect or unsuitable parameter values or settings can cause unintended movements, trigger signals, and compromise functional safety.

- Verify that parameter values and settings can only be modified by authorized personnel who fully understand each and every effect of such a modification.
- Verify that all parameter values and settings are correct by performing a test run.

Failure to follow these instructions can result in death, serious injury, and equipment damage.

 **WARNING****ELECTROMAGNETIC FIELDS**

Motors can generate strong electric and magnetic fields. This can cause interference in devices.

- Keep persons with electronic implants away from the motor.
- Do not operate devices in the vicinity of the motor which are sensitive to electromagnetic emission.

Failure to follow these instructions can result in death, serious injury, and equipment damage.

 **WARNING****HOT SURFACES**

The temperature of the motor and the holding brake can exceed 100 °C during operation.

- Avoid unprotected contact with hot surfaces.
- Do not allow flammable or heat-sensitive objects in the vicinity of hot surfaces.
- Before performing work on the motor or the holding brake, verify that you wait for a sufficient period of time to allow such parts to cool down to a temperature that allows for safe contact.

Failure to follow these instructions can result in death, serious injury, and equipment damage.

Power on the power supply to the product via the main switch.

Check the following points during commissioning:

- Operating state, potential error conditions, and protective equipment
 - During commissioning, perform tests for all operating states and error conditions. In doing so, verify that all protective equipment operates as planned and required.
- Correct operation of the motor
 - There are no overloads.
 - There are no unusual fluctuations in the speed of rotation. Immediately stop the product in the case of overloads or unusual fluctuations in the speed of rotation and verify correct mounting.
- Noise emission
 - Excessive noise emission can be an indication of incorrect mounting, for example, an uneven ground that causes mechanical stress at the output flange. Immediately stop the product in the case of high noise emission and verify correct mounting.

- Heat
 - Verify that the heat dissipation is sufficient and that the specified climatic environmental conditions are respected by performing a test run under maximum load conditions.

If the product and/or the machine into which the product is incorporated is temporarily decommissioned, it must be recommissioned. For recommissioning, the same prerequisites must be met as for initial commissioning.

Perform the same tests for each recommissioning of the product as for initial commissioning.

8.3 Setting the zero point

NOTICE

INVALID ZERO POINT

- Verify that a valid zero point is correctly set immediately after the following types of work are performed: dismounting of rotary plate/output flange as well as dismounting or replacement of the motor or the metal bellows coupling/tensioning kit, the servo drive/controller and the battery of the controller.

Failure to follow these instructions can result in equipment damage.

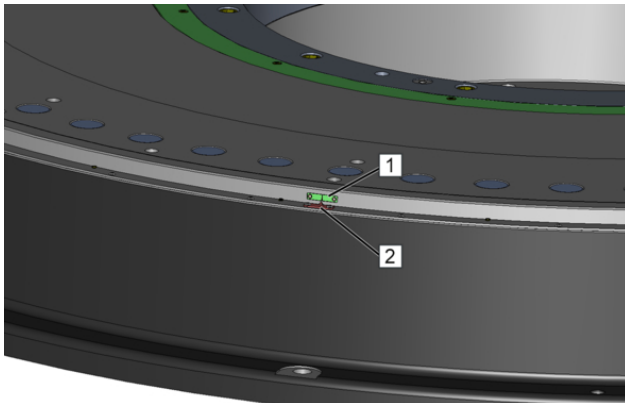

For setting the zero point, zero point marks are provided at the housing [2] and at the output flange [1] of the product.

It is also possible to select a different zero point. If a different zero point is used, the corresponding zero point marks must be added to the product (like the factory-provided zero point marks).

1. Power on the power supply to the product via the main switch.
2. Rotate the output flange via the controller (for example, W.A.S. 2) in operating mode Jog or via the hand crank until the two zero point marks are facing.
3. Set the zero point in the controller and save it.

9 Operation

9.1 Basic information on operation

WARNING

UNINTENDED EQUIPMENT OPERATION

Incorrect or unsuitable parameter values or settings can cause unintended movements, trigger signals, and compromise functional safety.

- Verify that parameter values and settings can only be modified by authorized personnel who fully understand each and every effect of such a modification.
- Verify that all parameter values and settings are correct by performing a test run.

Failure to follow these instructions can result in death, serious injury, and equipment damage.

WARNING

UNANTICIPATED MOVEMENT OF THE OUTPUT FLANGE

If the holding brake fails, the output flange can move even if the motor is at a standstill.

- Block or safeguard the output flange in such a way that a movement of the output flange is safely prevented before starting work on the output flange.

Failure to follow these instructions can result in death, serious injury, and equipment damage.

WARNING

ELECTROMAGNETIC FIELDS

Motors can generate strong electric and magnetic fields. This can cause interference in devices.

- Keep persons with electronic implants away from the motor.
- Do not operate devices in the vicinity of the motor which are sensitive to electromagnetic emission.

Failure to follow these instructions can result in death, serious injury, and equipment damage.

The product is a partly complete machine pursuant Directive 2006/42/EU and intended to be incorporated into or assembled with other machinery. The information required for operation results from the functionality of the machine or system into which the product is incorporated and from the application implemented with it.

The instructions for the safe operation of the final machine or system must be provided by the system integrator (the person who incorporates the product in a machine pursuant to Directive 2006/42/EU) and/or the operator in the form of a manual with operating instructions, [see chapter 2.3](#).

These operating instructions must be a complete manual which describes all work on and with the product and which contains all information relevant to the product. The system integrator and/or operator must ensure compliance of the operating instructions with all applicable directives, regulations, and standards.

10 Troubleshooting

10.1 Issue, cause and remedy

 **DANGER**

ELECTRIC SHOCK CAUSED BY LIVE PARTS

- Disconnect the mains voltage supply before performing the work and ensure that it cannot be switched on.
- Verify that no hazards can be caused by electrically conductive objects.
- Verify that all cables for the power supply are disconnected from power.
- Verify that all electrical connections are made to the specifications in the wiring diagrams.

Failure to follow these instructions will result in death or serious injury.

 **WARNING**

MOVING PARTS

- Verify that the zone of operation of the moving product/machine parts is safeguarded.

Failure to follow these instructions can result in death, serious injury, and equipment damage.

 **WARNING**

HOT SURFACES

The temperature of the motor and the holding brake can exceed 100 °C during operation.

- Avoid unprotected contact with hot surfaces.
- Do not allow flammable or heat-sensitive objects in the vicinity of hot surfaces.
- Before performing work on the motor or the holding brake, verify that you wait for a sufficient period of time to allow such parts to cool down to a temperature that allows for safe contact.

Failure to follow these instructions can result in death, serious injury, and equipment damage.

Issue	Cause	Remedy
Output flange does not rotate or does not reach the next position	Motor is inoperable	<ul style="list-style-type: none"> ▪ Replace the motor, see chapter 12
	Metal bellows coupling inoperative	<ul style="list-style-type: none"> ▪ Replace the metal bellows coupling, see chapter 12
	Output flange is mechanically blocked	<ul style="list-style-type: none"> ▪ Verify that the output flange is not mechanically block at the top or the underside ▪ Remove the cause of the block



Issue	Cause	Remedy
	During initial commissioning: The output flange is subject to mechanical tension	<ul style="list-style-type: none">▪ Verify that the mounting site is level und verify correct mounting▪ Verify the installation
Other issues	Other issues can be related to the controller/software	<ul style="list-style-type: none">▪ See the description of the controller for removing errors which are caused by the controller, see chapter.

11 Cleaning

11.1 Performing cleaning

DANGER

ELECTRIC SHOCK CAUSED BY LIVE PARTS

- Disconnect the mains voltage supply before performing the work and ensure that it cannot be switched on.
- Verify that no hazards can be caused by electrically conductive objects.
- Verify that all cables for the power supply are disconnected from power.
- Verify that all electrical connections are made to the specifications in the wiring diagrams.

Failure to follow these instructions will result in death or serious injury.

WARNING

UNANTICIPATED MOVEMENT OF THE OUTPUT FLANGE

In the case of vertical installation of the product (horizontal axis of rotation), the output flange may move due to forces of gravity or the load when the holding brake is released or when the drive and the output flange are decoupled.

- Block or safeguard the output flange ring in such a way that a movement of the output flange is safely prevented before releasing the brake or decoupling the drive and the output flange.

Failure to follow these instructions can result in death, serious injury, and equipment damage.

WARNING

MISSING PROTECTIVE EQUIPMENT

- Immediately reinstall protective equipment that you may have removed to perform maintenance work after having completed the maintenance work and verify the effectiveness of the protective equipment.

Failure to follow these instructions can result in death, serious injury, and equipment damage.

WARNING

MOVING PARTS

- Verify that the zone of operation of the moving product/machine parts is safeguarded.

Failure to follow these instructions can result in death, serious injury, and equipment damage.

 **WARNING**

HOT SURFACES

The temperature of the motor and the holding brake can exceed 100 °C during operation.

- Avoid unprotected contact with hot surfaces.
- Do not allow flammable or heat-sensitive objects in the vicinity of hot surfaces.
- Before performing work on the motor or the holding brake, verify that you wait for a sufficient period of time to allow such parts to cool down to a temperature that allows for safe contact.

Failure to follow these instructions can result in death, serious injury, and equipment damage.

Comply with all instructions concerning cleaning of electrical components and additional components provided in the applicable documents, [see chapter](#).

Cleaning agents

Use the following cleaning agents for cleaning the product:

Component	Cleaning agents
Stationary center part	Neutral, mildly alkaline
Housing heavy duty rotary indexing table	
Output flange	

1. Remove fine impurities and dust with a dry, lint-free cloth.
2. Use a wet cloth and a neutral, mildly alkaline cleaning agent to remove stains on the housing and/or on the output flange.
3. Dry the cleaned areas.
4. Remove all equipment from the product.
5. Restore the readiness for operation of the product.

12 Maintenance

12.1 Maintenance plan

When	Activity
Once per month	<ul style="list-style-type: none"> Verify correct oil level via the oil sight glass of the product
Once per year	<ul style="list-style-type: none"> Clean all surfaces of the product, see chapter 11.1
	<ul style="list-style-type: none"> Verify tight connection of all screw connections
	<ul style="list-style-type: none"> Visual inspection metal bellows coupling
If required	<ul style="list-style-type: none"> Replace the motor, see chapter 12
	<ul style="list-style-type: none"> Replace the metal bellows coupling, see chapter 12

12.2 Lubricant

The gear of the product runs in an oil bath and features lifetime lubrication.

For information on the lubricant and the lubricant volume [see chapter 4](#).

12.3 Dismounting the motor and the metal bellows coupling

DANGER

ELECTRIC SHOCK CAUSED BY LIVE PARTS

- Disconnect the mains voltage supply before performing the work and ensure that it cannot be switched on.
- Verify that no hazards can be caused by electrically conductive objects.
- Verify that all cables for the power supply are disconnected from power.
- Verify that all electrical connections are made to the specifications in the wiring diagrams.

Failure to follow these instructions will result in death or serious injury.

WARNING

UNANTICIPATED MOVEMENT OF THE OUTPUT FLANGE

In the case of vertical installation of the product (horizontal axis of rotation), the output flange may move due to forces of gravity or the load when the holding brake is released or when the drive and the output flange are decoupled.

- Block or safeguard the output flange ring in such a way that a movement of the output flange is safely prevented before releasing the brake or decoupling the drive and the output flange.

Failure to follow these instructions can result in death, serious injury, and equipment damage.

 **WARNING****MISSING PROTECTIVE EQUIPMENT**

- Immediately reinstall protective equipment that you may have removed to perform maintenance work after having completed the maintenance work and verify the effectiveness of the protective equipment.

Failure to follow these instructions can result in death, serious injury, and equipment damage.

 **WARNING****MOVING PARTS**

- Verify that the zone of operation of the moving product/machine parts is safeguarded.

Failure to follow these instructions can result in death, serious injury, and equipment damage.

 **WARNING****HOT SURFACES**

The temperature of the motor and the holding brake can exceed 100 °C during operation.

- Avoid unprotected contact with hot surfaces.
- Do not allow flammable or heat-sensitive objects in the vicinity of hot surfaces.
- Before performing work on the motor or the holding brake, verify that you wait for a sufficient period of time to allow such parts to cool down to a temperature that allows for safe contact.

Failure to follow these instructions can result in death, serious injury, and equipment damage.

 **WARNING****FALLING PARTS**

- Secure the motor so it cannot fall down before loosening the screws.

Failure to follow these instructions can result in death, serious injury, and equipment damage.

1. Remove all connectors from the motor [1].

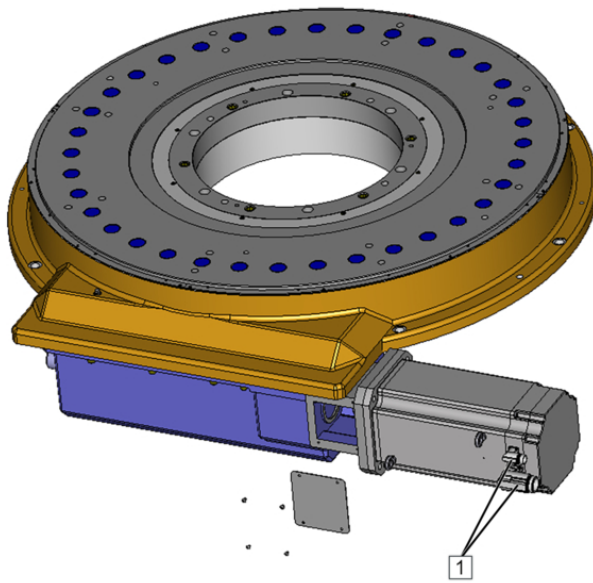

2. Remove the screws from the cover [2].
3. Remove the cover.

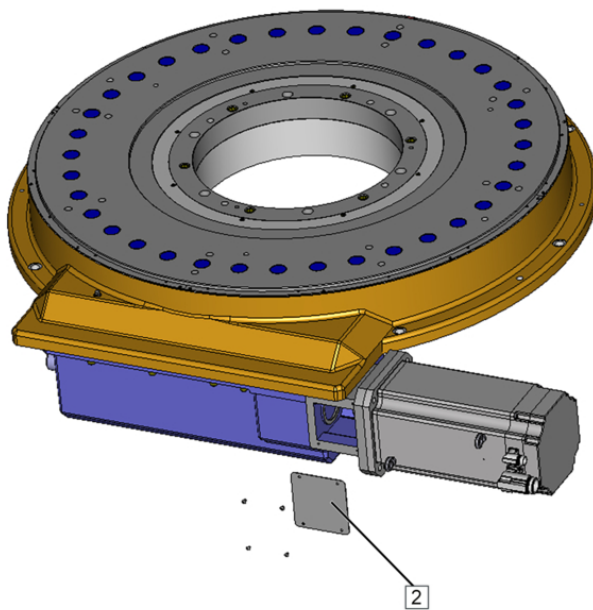

For the subsequent steps, the locking screw at the gear end of the metal bellows coupling must be visible. If the locking screw at the gear end is not visible, you must change the position of the metal bellows coupling.

The position of the metal bellows coupling can only be changed if the holding brake has been released. The holding brake can only be released by applying the brake voltage. Use an external 24 V power supply to apply the brake voltage.

- Do not switch on the power supply to the product (main switch).
 - Prior to performing any work, verify that no mains voltage is applied to the product.
 - Verify that releasing the holding brake cannot cause any movement in the system (for example, in the case of vertical mounting position of the product).
 - Verify that releasing the holding brake cannot cause any other hazards.
4. Connect an external 24 V power supply to the terminals of the holding brake.
 5. Apply 24 V to the holding brake.

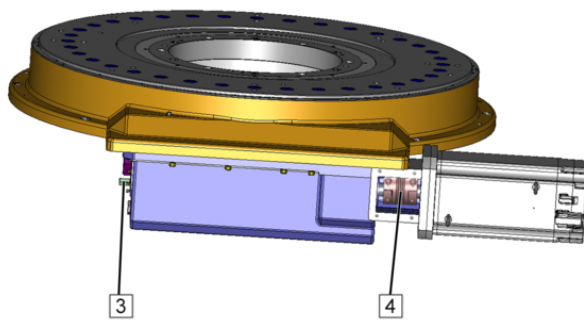

6. Remove the protective cap from the shaft [3].
7. Turn the shaft [3] until the locking screw at the driving cam end of the metal bellows coupling [4] is visible.
8. Disconnect the 24 V power supply from the terminals of the holding brake.
9. Verify that the holding brake has been properly applied before continuing your work.
10. Loosen the locking screw at the driving cam end of the metal bellows coupling [4].
11. Loosen the four screws [5] from the motor.

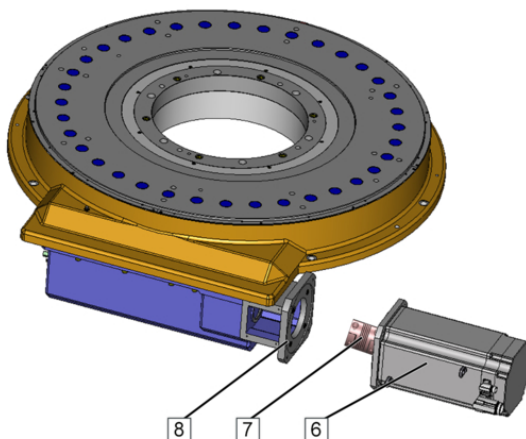
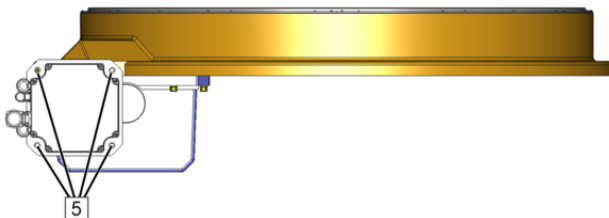

12. Remove the motor [6] with the metal bellows coupling [7] from the motor flange [8].
 13. Loosen the locking screw at the motor end of the metal bellows coupling [7].
 14. Remove the metal bellows coupling [7] from the motor [6].
- ✓ Motor and metal bellows coupling are uninstalled.

12.4 Mounting the motor and the metal bellows coupling

DANGER

ELECTRIC SHOCK CAUSED BY LIVE PARTS

- Disconnect the mains voltage supply before performing the work and ensure that it cannot be switched on.
- Verify that no hazards can be caused by electrically conductive objects.
- Verify that all cables for the power supply are disconnected from power.
- Verify that all electrical connections are made to the specifications in the wiring diagrams.

Failure to follow these instructions will result in death or serious injury.

WARNING

UNANTICIPATED MOVEMENT OF THE OUTPUT FLANGE

In the case of vertical installation of the product (horizontal axis of rotation), the output flange may move due to forces of gravity or the load when the holding brake is released or when the drive and the output flange are decoupled.

- Block or safeguard the output flange ring in such a way that a movement of the output flange is safely prevented before releasing the brake or decoupling the drive and the output flange.

Failure to follow these instructions can result in death, serious injury, and equipment damage.

WARNING

MISSING PROTECTIVE EQUIPMENT

- Immediately reinstall protective equipment that you may have removed to perform maintenance work after having completed the maintenance work and verify the effectiveness of the protective equipment.

Failure to follow these instructions can result in death, serious injury, and equipment damage.

WARNING

MOVING PARTS

- Verify that the zone of operation of the moving product/machine parts is safeguarded.

Failure to follow these instructions can result in death, serious injury, and equipment damage.

WARNING

UNSUITABLE SPARE PARTS AND ACCESSORIES

- Only use spare parts and accessories which are approved by the manufacturer.
- Only replace the motor by a motor of the same type with the same technical data (nameplate of the motor and nameplate of the product).

Failure to follow these instructions can result in death, serious injury, and equipment damage.

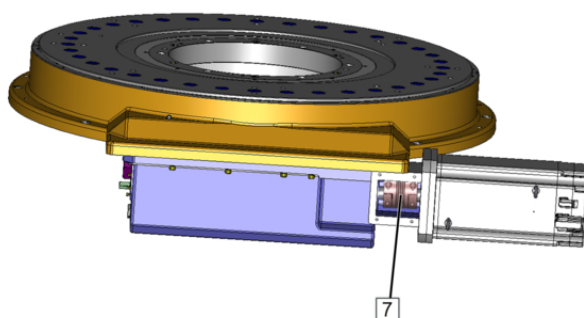
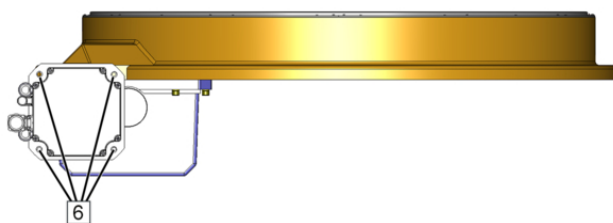
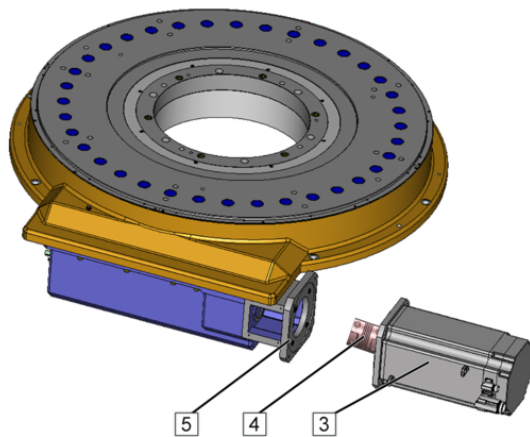
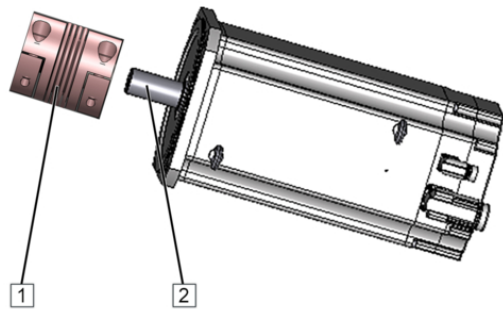

Observe the property class and the tightening torques of the screw connections, [see chapter 7.2.2.](#)

1. Push the metal bellows coupling [1] onto the motor shaft [2] (precise fit).
2. Verify that the locking screw at the driving cam end of the metal bellows coupling is visible when mounted (motor at housing of the driving cam).
3. Verify that the metal bellows coupling neither contacts the motor nor the housing of the driving cam when the motor is mounted.
4. Tighten the locking screw at the motor end of the metal bellows coupling [1] with a tightening torque of 110 Nm.
5. Position the motor [3] with the metal bellows coupling [4] at the motor flange [5].
6. Verify precise fit of the metal bellows coupling when pushing it onto the shaft of the driving cam.

7. Tighten the four screws [6] of the motor.

8. Tighten the locking screw at the driving cam end of the metal bellows coupling [7] with a tightening torque of 110 Nm.

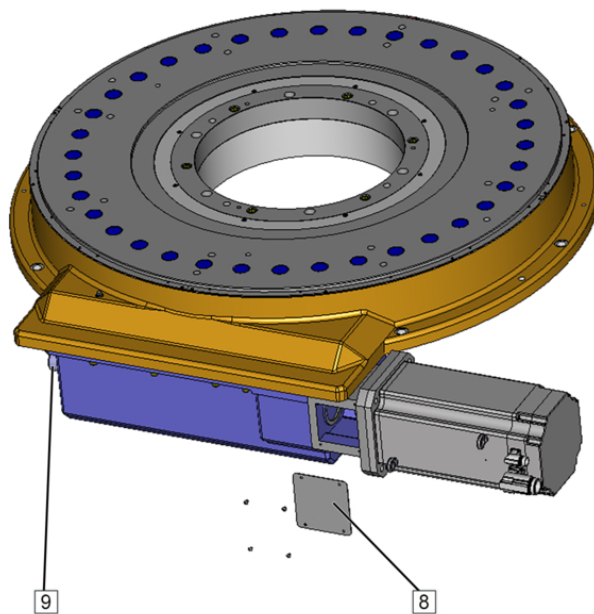

9. Mount the cover [8] by means of the screws.
10. Mount the cover [9] by means of the screws.
11. Connect the motor, [see chapter 1.4](#).
12. Remove all tools and equipment.
13. Set the zero point, [see chapter 8.3](#).
14. Perform a test run.

13 Decommissioning

13.1 Decommissioning the product

1. Switch off the product and secure it against unintended switching on.
2. Remove all workpieces and all other objects not belonging to the product from the product.
3. In the case of recommissioning, follow the instructions described, [see chapter 8](#).

14 Dismounting

14.1 Dismounting the product

WARNING

FALLING, TOPPLING, OR LOWERING LOADS

Insufficiently rated load lifting and handling equipment may break. Transportation vehicles, lifting gear, chains, belts, and other equipment not rated for the product may fail or tilt.

- Only use transportation vehicles, lifting gear, chains, belts, and other lifting and handling equipment that comply with all applicable regulations and that are rated for the weight of the product including packaging.
- Verify that there are no persons in the danger zone.
- Verify that the product is properly secured against falling and toppling.

Failure to follow these instructions can result in death, serious injury, and equipment damage.

1. Switch off the supply voltage.
2. Dismount the product (reverse sequence of steps), [see chapter 7](#).

15 Disposal

15.1 Disposing of the product

Dispose of the product in compliance with all applicable directives, standards, and safety regulations.

Environmental protection

Dispose of lubricants, greases, residue of cleaning agents and other non-recyclable materials according to the applicable directives, standards, and safety regulations.

16 Service and spare parts

16.1 Service

If you need the assistance of our service departments, please provide the following information:

- Serial number of the product (see nameplate)
- Description of the problem
- Time of occurrence and circumstances of the problem
- Suspected cause

You can reach our service department from Monday to Friday 08:00 a.m to 05:00 p.m. via the

Service number +49-6281-5208-5999

or at service@weiss-gmbh.de

A voice message system is available if you call outside of the hours specified.

16.2 Ordering spare parts

WARNING

UNSUITABLE SPARE PARTS AND ACCESSORIES

- Only use spare parts and accessories which are approved by the manufacturer.

Failure to follow these instructions can result in death, serious injury, and equipment damage.

Please provide the following information when ordering spare parts:

- Serial number of the product (see nameplate)
- Part number of the spare part according to spare parts list
- Quantity of spare parts required

Please direct your spare parts order to:

WEISS GmbH

Siemensstraße 17

74722 Buchen

Telephone: +49-6281-5208-5999

Telefax: +49-6281-5208-99

service@weiss-gmbh.de

www.weiss-international.com

Visit our website for information on our offices and representations.



Warranty

17 Warranty

17.1 Information on warranty

See our website for our General Terms and Conditions at www.weiss-international.com or your purchase order.



**INSPIRING PEOPLE
GREAT SOLUTIONS**

WEISS GmbH

Siemensstraße 17 74722 Buchen
Telefon 06281 5208-0 Telefax 06281 5208-99
info@weiss-international.com
www.weiss-international.com